





PCTPMT2012

Perfecting the Air

- Warning**  Ask a qualified installer or contractor to install this product. Do not try to install the product yourself. Improper installation can result in water or refrigerant leakage, electrical shock, fire or explosion.
- Use only those parts and accessories supplied or specified by Daikin. Ask a qualified installer or contractor to install those parts and accessories. Use of unauthorised parts and accessories or improper installation of parts and accessories can result in water or refrigerant leakage, electrical shock, fire or explosion.
  - Read the user's manual carefully before using this product. The user's manual provides important safety instructions and warnings. Be sure to follow these instructions and warnings.
  - About harmonics, since this product is equipped with an inverter, harmonics will be generated. If local laws require the suppression of harmonics on the building, please take harmonic suppression measures on the electrical equipment side. Please contact your local sales company for details.
- Notice**  If you have any enquiries, please contact your local importer, distributor and/or retailer.

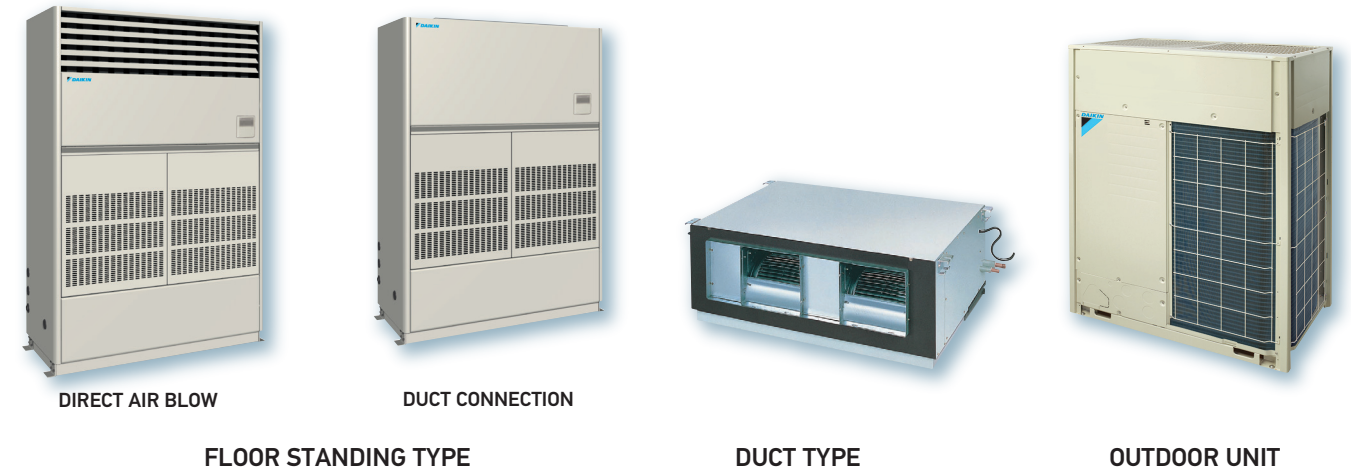

**Cautions on product corrosion**

1. Air conditioners should not be installed in areas where corrosive gases, such as acid gas or alkaline gas, are produced.
2. If the outdoor unit is to be installed close to the sea shore, direct exposure to the sea breeze should be avoided. If you need to install the outdoor unit close to the sea shore, contact your local distributor.

**Notice about harmonics**

1. Since this machine is equipped with an inverter, harmonics will be generated.
2. If local laws require the suppression of harmonics on the building, please take harmonic suppression measures on the electrical equipment side.

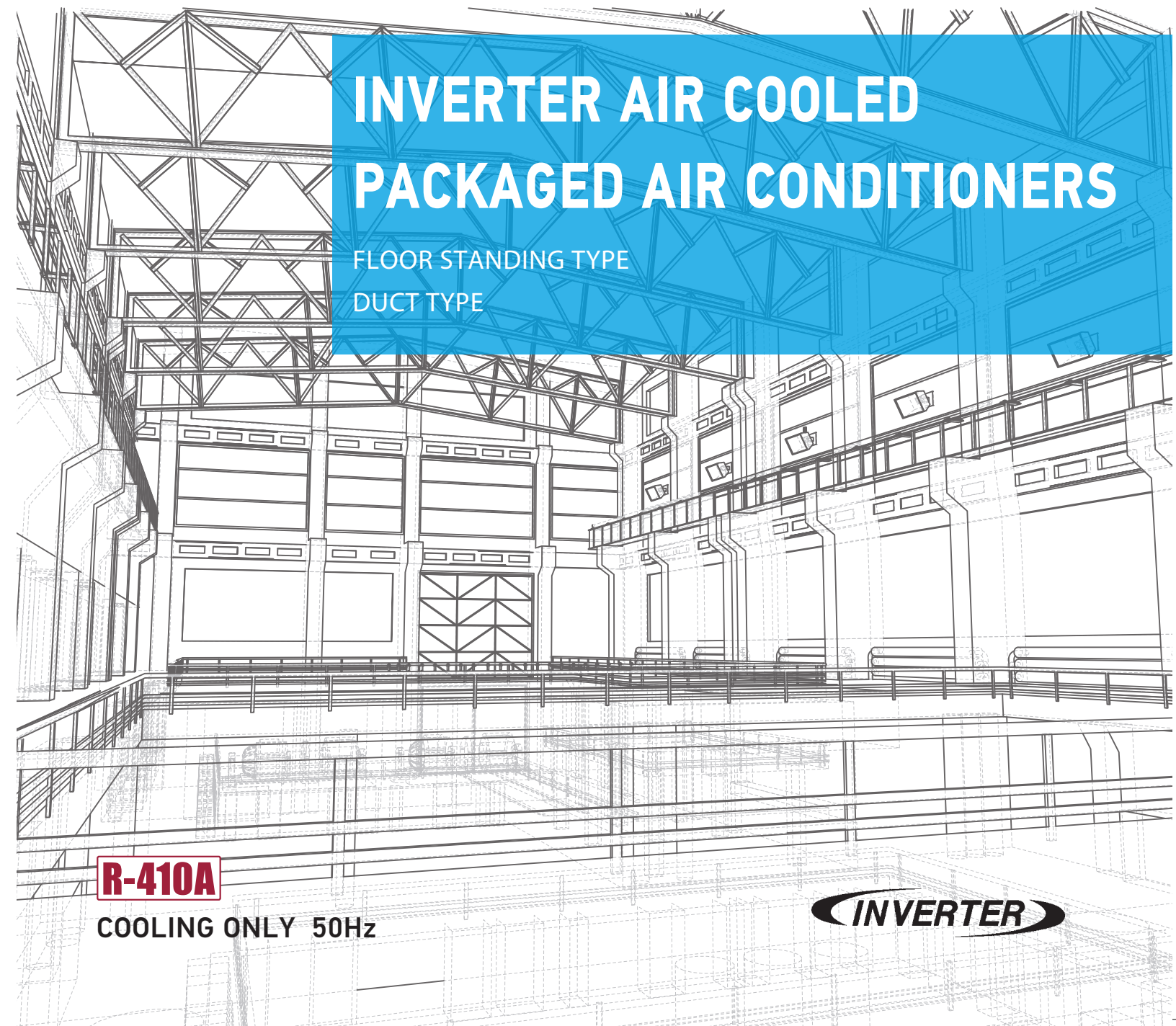

**CÔNG TY CỔ PHẦN DAIKIN AIR CONDITIONING (VIETNAM)**

**VĂN PHÒNG CHÍNH**  
Tầng 12, tòa nhà Nam Á, 201-203 Cách Mạng Tháng 8, P.4, Q.3, TP. Hồ Chí Minh, Tel: (028) 62 504 888

**CHI NHÁNH HÀ NỘI**  
Tầng 12, tòa nhà Ocean Park Tower,  
1 Đào Duy Anh, Q. Đống Đa, Hà Nội  
Tel: (024) 3565 7677

**CHI NHÁNH CẦN THƠ**  
37-38 Võ Nguyên Giáp, Khu dân cư Phú An,  
P. Phú Thứ, Q. Cái Răng, TP. Cần Thơ  
Tel: (0292) 626 9977

**CHI NHÁNH HẢI PHÒNG**  
Số 7 lô 8A đường Lê Hồng Phong,  
P. Đông Khê, Q. Ngô Quyền, TP. Hải Phòng  
Tel: (0225) 383 2900

**CHI NHÁNH KHÁNH HÒA**  
1200 Lê Hồng Phong, P. Phước Long,  
TP. Nha Trang  
Tel: (0258) 625 8158

**CHI NHÁNH ĐÀ NẴNG**  
Tầng 12, tòa nhà PVcomBank, Lô A2.1, Đường 30/4,  
P. Hòa Cường Bắc, Q. Hải Châu, TP. Đà Nẵng  
Tel: (0236) 362 4250

**CHI NHÁNH NGHỆ AN**  
Số 2 Nguyễn Sỹ Sách, P. Hưng Bình, TP. Vinh  
Tel: (0238) 872 7785











 DaikinVietnam  www.daikin.com.vn

Specifications, designs and other content appearing in this brochure are current as of September 2020 but subject to change without notice.









# Inverter Packaged Air Conditioner Line Up for Factories and Offices

## Product Line Up **R-410A**

### FLOOR STANDING TYPE Cooling only 50Hz

Capacity		20.0	26.7	40.0	50.0
kW		20.0	26.7	40.0	50.0
Btu/h		68,000	91,000	136,000	171,000
FLOOR STANDING TYPE	<b>DIRECT AIR BLOW</b> <small>Specifications Page 5</small>	 FVGR200PV1(4)	 FVGR250PV1(4)		
	<b>DUCT CONNECTION</b> <small>Specifications Page 5</small>		 FVPR250PY1(4)	 FVPR400PY1(4)	 FVPR500PY1(4)
<b>OUTDOOR UNIT</b>		 RZUR200PY1(4)	 RZUR250PY1(4)	 RZUR400PY1(4)	 RZUR500PY1(4)

### DUCT TYPE Cooling only 50Hz

Capacity		20.0	26.7	40.0	50.0
kW		20.0	26.7	40.0	50.0
Btu/h		68,000	91,000	136,000	171,000
<b>DUCT TYPE</b> <small>Specifications Page 6</small>		 FDR200PY1(4)	 FDR250PY1(4)	 FDR400PY1(4)	 FDR500PY1(4)
<b>OUTDOOR UNIT</b>		 RZUR200PY1(4)	 RZUR250PY1(4)	 RZUR400PY1(4)	 RZUR500PY1(4)

#### DIRECT AIR BLOW

##### Direct air blow from indoor unit with plenum

- Comfortable factory air conditioning using multiple indoor units installed in accordance with the space.
- Installation is next to walls, so units will not affect the factory layout even if the changes are made.

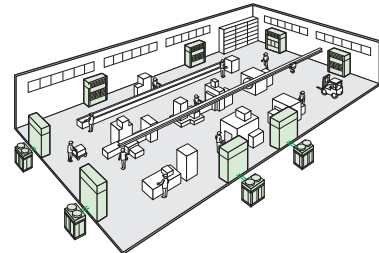

#### DUCT CONNECTION

##### DUCT TYPE

##### Air blow via connected ducts

- Comfortable air conditioning of the entire factory by connecting a blow duct at the top of the indoor unit.
- Note: Ducts to be procured locally.

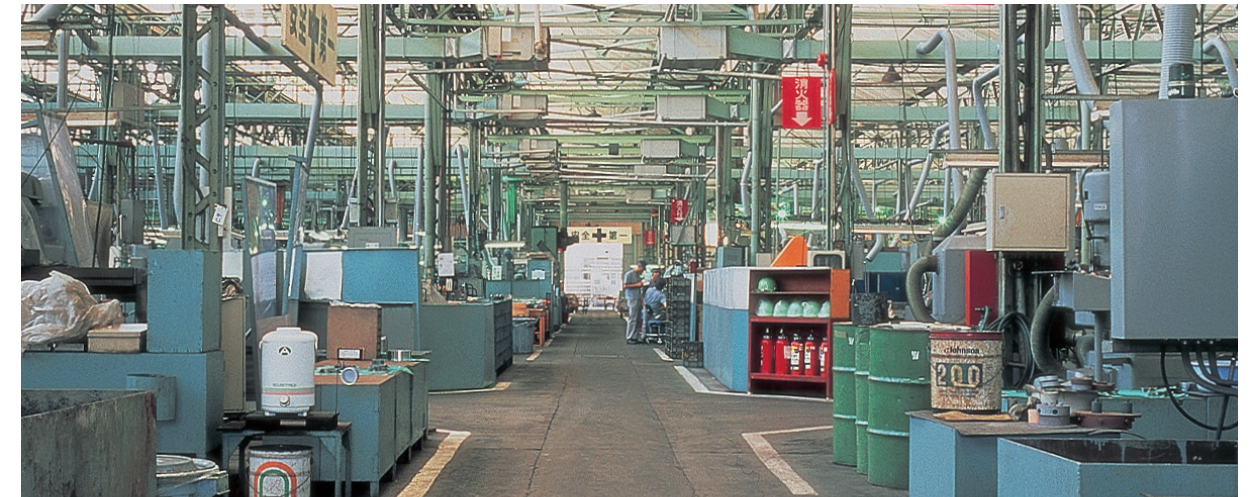
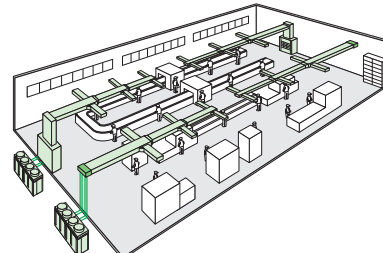

### Extended operation range up to 49°C

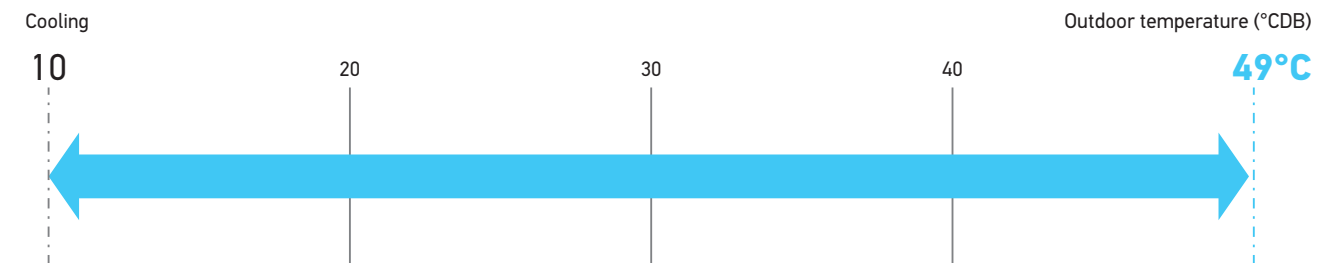

Note: When outdoor temperature falls below 10°C, the thermostat shuts OFF, the outdoor unit stops, and operation switches from cooling to fan operation.

## Design flexibility

### Designed for long refrigerant piping

70 m maximum length and 50 m maximum level difference to cover medium- and large-scale building needs.

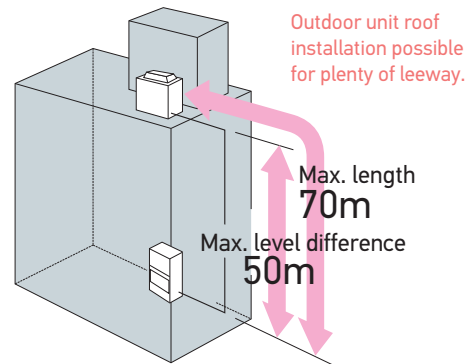

### High external static pressure

The outdoor unit has been achieved high external static pressure up to 78.4 Pa, ensuring the efficient heat dissipation and stable operation of equipment in either hierarchical or intensive arrangement.

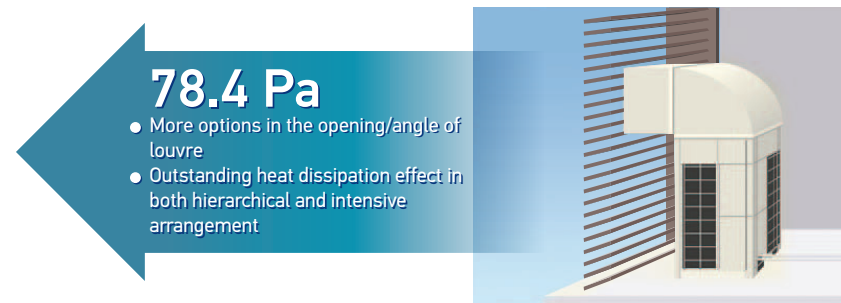

### Nighttime quiet operation function

The nighttime quiet operation function automatically suppresses the nighttime operating sound by reducing operation capacity to maintain the quiet environment of the neighborhood. Three selectable modes are available depending on the required level.

\*1. Initial setting is 8 hours. Can be selected from 6, 8 and 10 hours.  
 \*2. Initial setting is 9 hours. Can be selected from 8, 9 and 10 hours.  
 \*3. In case of RZUR250PY1(4).

Notes: • This function is available in setting at site.  
 • The operating sound in quiet operation mode is the actual value measured by our company.  
 • The relationship of outdoor temperature (load) and time shown above is just an example.

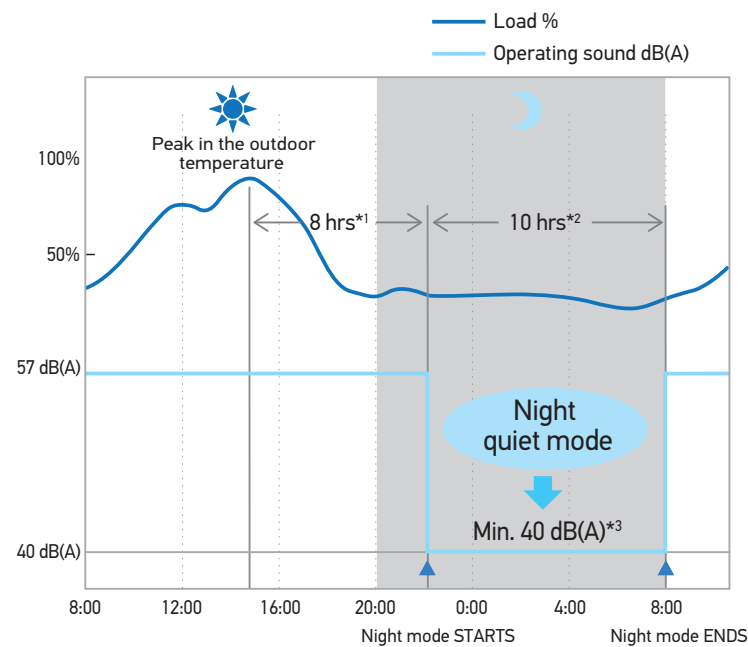

## Reliability

### Backup operation function

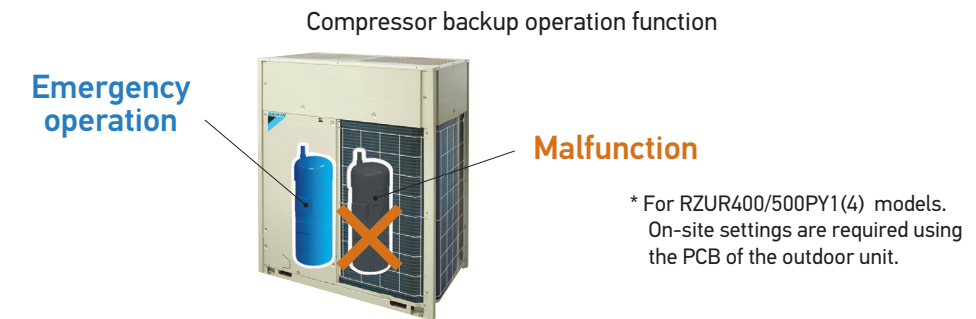

### Centralized management system extension

Centralized management can integrate with D-BACS system with high speed data transfer. Centralized control is now available when using with Inverter packaged air conditioners. Display of air filter cleaning times and self-inspection function for simple maintenance.

## Enhanced varieties of factory modification

Factory Modification	Floor Standing Type		Duct Type
	Direct Air Blow	Duct Connection	
Change fan motor and pulley	-	<input type="checkbox"/>	-
Discharge grill plenum chamber	<input type="radio"/>	<input type="checkbox"/>	-
Side discharge grill on discharge plenum chamber	<input type="checkbox"/>	<input type="checkbox"/>	-
Front suction high efficiency filter chamber	-	<input type="checkbox"/>	-
Front suction base flange for front suction high efficiency filter chamber	-	<input type="checkbox"/>	-
Suction grill for front suction high efficiency filter chamber	-	<input type="checkbox"/>	-
Rear suction	-	<input type="checkbox"/>	-
Drain pump	<input type="checkbox"/>	<input type="checkbox"/>	-
Change 2 blowers to reduce noise for direct flow	-	<input type="checkbox"/> *	-
2 step airflow by toggle switch	<input type="checkbox"/>	-	-

Note:  
 \* For FVPR500PY1(4) only

# Specifications

## FLOOR STANDING TYPE

### DIRECT AIR BLOW

Model Name	Indoor unit		FVGR200PV1(4)	FVGR250PV1(4)
	Outdoor unit		RZUR200PY1(4)	RZUR250PY1(4)
Cooling capacity <sup>1</sup> (Max.)	Btu/h		68,000 (74,000)	91,000 (96,000)
	kW		20.0 (21.7)	26.7 (28.1)
Power consumption <sup>1</sup>	kW		7.25	9.64
Indoor unit	Power supply		1 Phase, 220-240 V, 50 Hz	
	Colour		Ivory White	
	Air flow rate (H)	m <sup>3</sup> /min	80	
		cfm	2,830	
	Fan	Motor output	0.245x2	
		Drive	Direct Drive 3 Speed	
	Dimensions (HxWxD)		1,870x1,170x510	
	Machine weight		149	
	Sound level		61	
	Drain		PS 1B Internal thread	
Outdoor unit	Power supply		3 Phase, 380-415 V, 50 Hz	
	Colour		Ivory white	
	Compressor	Type	Hermetically sealed scroll type	
		Motor output	3.4x1	4.5x1
	Air flow rate (H)	m <sup>3</sup> /min	178	
	Dimensions (HxWxD)		1,657x930x765	
	Machine weight		175	185
	Sound level <sup>2</sup>		56	57
	Operation range		°CDB 10 to 49	
	Refrigerant charge		5.9	6.7
Refrigerant Piping	Liquid	Ø 9.5 (Brazing)		
	Gas	Ø 19.1 (Brazing)	Ø 22.2 (Brazing)	
Max. piping length		70 (equivalent length 90 m)		
Max. level difference		50		

## FLOOR STANDING TYPE

### DUCT CONNECTION

Model Name	Indoor unit		FVPR250PY1(4)	FVPR400PY1(4)	FVPR500PY1(4)
	Outdoor unit		RZUR250PY1(4)	RZUR400PY1(4)	RZUR500PY1(4)
Cooling capacity <sup>1</sup> (Max.)	Btu/h		91,000 (96,000)	136,000 (150,000)	171,000 (176,000)
	kW		26.7 (28.1)	40.0 (44.0)	50.0 (51.6)
Power consumption <sup>1</sup>	kW		9.27	17.02	23.26
Indoor unit	Power supply		3 Phase, 380-415 V, 50 Hz		
	Colour		Ivory White		
	Air flow rate (H)	m <sup>3</sup> /min	80	120	162
		cfm	2,830	4,240	5,720
	External static pressure <sup>3</sup>		Pa 147		
	Fan	Motor output	1.5	2.2	3.7
		Drive	Belt Drive		
	Dimensions (HxWxD)		1,740x1,170x510	1,870x1,170x720	1,870x1,470x720
	Machine weight		156	200	250
	Sound level		61	62	63
Drain		PS 1B Internal thread			
Outdoor unit	Power supply		3 Phase, 380-415 V, 50 Hz		
	Colour		Ivory white		
	Compressor	Type	Hermetically sealed scroll type		
		Motor output	4.5x1	(3.5x1)+(3.5x1)	(4.9x1)+(4.2x1)
	Air flow rate (H)	m <sup>3</sup> /min	178	257	297
	Dimensions (HxWxD)		1,657x930x765	1,657x1,240x765	
	Machine weight		185	260	291
	Sound level <sup>2</sup>		57	60	65
	Operation range		°CDB 10 to 49		
	Refrigerant charge		6.7	8.2	11.7
Refrigerant Piping	Liquid	Ø 9.5 (Brazing)			
	Gas	Ø 22.2 (Brazing)	Ø 28.6 (Brazing)		
Max. piping length		70 (equivalent length 90 m)			
Max. level difference		50			

Note :

\*1. Indoor temp.: 27°CDB, 19°CWB / outdoor temp.: 35°CDB / Equivalent piping length: 7.5 m, level difference: 0 m.

\*2. Anechoic chamber conversion value, measured at a point 1 m in front of the unit at a height of 1.5 m.

During actual operation, these values are normally somewhat higher as a result of ambient conditions and oil recovery mode.

When there is concern for noise the surrounding area such as residences, we recommend investigating the installation location and taking soundproofing measures.

\*3. The value is the external static pressure with standard pulley.

## DUCT TYPE

Model Name	Indoor unit		FDR200PY1(4)	FDR250PY1(4)	FDR400PY1(4)	FDR500PY1(4)
	Outdoor unit		RZUR200PY1(4)	RZUR250PY1(4)	RZUR400PY1(4)	RZUR500PY1(4)
Cooling capacity <sup>1</sup> (Max.)	Btu/h		68,000 (74,000)	91,000 (96,000)	136,000 (150,000)	171,000 (176,000)
	kW		20.0 (21.7)	26.7 (28.1)	40.0 (44.0)	50.0 (51.6)
Power consumption <sup>1</sup>	kW		8.06	10.39	17.86	26.74
Indoor unit	Power supply		3 Phase, 380-415 V, 50 Hz			
	Colour		Galvanized Steel			
	Air flow rate (H)	m <sup>3</sup> /min	78		166	
		cfm	2,750		5,860	
	External static pressure <sup>3</sup>		Pa 98		147	
	Fan	Motor output	1.5		3.7	
		Drive	Belt drive			
	Dimensions (HxWxD)		500x1,330x850		625x1,980x850	
	Machine weight		108		191	
	Sound level		53		60	
Drain		PS 3/4B Internal thread		PS 1B Internal thread		
Outdoor unit	Power supply		3 Phase, 380-415 V, 50 Hz			
	Colour		Ivory white			
	Compressor	Type	Hermetically sealed scroll type			
		Motor output	3.4x1	4.5x1	(3.5x1)+(3.5x1)	(4.9x1)+(4.2x1)
	Air flow rate (H)	m <sup>3</sup> /min	178		257	297
	Dimensions (HxWxD)		1,657x930x765		1,657x1,240x765	
	Machine weight		175	185	260	291
	Sound level <sup>2</sup>		56	57	60	65
	Operation range		°CDB 10 to 49			
	Refrigerant charge		5.9	6.7	8.2	11.7
Refrigerant Piping	Liquid	Ø 9.5(Brazing)		Ø 12.7 (Brazing)		
	Gas	Ø 19.1 (Brazing)	Ø 22.2 (Brazing)		Ø 28.6 (Brazing)	
Max. piping length		70 (equivalent length 90 m)				
Max. level difference		50				

Note :

\*1. Indoor temp.: 27°CDB, 19°CWB / outdoor temp.: 35°CDB / Equivalent piping length: 7.5 m, level difference: 0 m.

\*2. Anechoic chamber conversion value, measured at a point 1 m in front of the unit at a height of 1.5 m.

During actual operation, these values are normally somewhat higher as a result of ambient conditions and oil recovery mode.

When there is concern for noise the surrounding area such as residences, we recommend investigating the installation location and taking soundproofing measures.

\*3. The value is the external static pressure with standard pulley.

# Option

## FLOOR STANDING TYPE

Option	Direct Air Blow	Duct Connection		
	FVGR-PV1(4)	FVPR250PY1(4)	FVPR400PY1(4)	FVPR500PY1(4)
Discharge grill plenum chamber (Including pulley and belt)	—	BPCV10P	BPCV16P	BPCV20P
Filter chamber for clean room	—			

## CONTROL SYSTEM

Option	FVGR-PV1(4)	FVPR-PY1(4)	FDR-PY1(4)
Simplified remote controller		—	BRC2E61
Navigator remote controller		—	BRC1E63
Wiring adaptor for electrical appendices (Group control adaptor)		KRP4AA51 H	
Adaptor for wiring (operation status output)		BRP11B61	
Remote sensor (for indoor temperature)		BRCS01A-1	
Mounting plate for adaptor PCB		—	BRP45A1

Note :

Mounting plate I is necessary for each adaptor marked H.

# FAN PERFORMANCE

## FLOOR STANDING TYPE

### DUCT CONNECTION

FVPR250PY1(4)

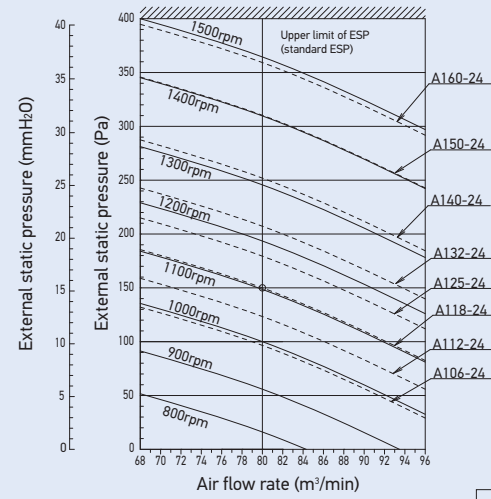

4D064265

FVPR400PY1(4)

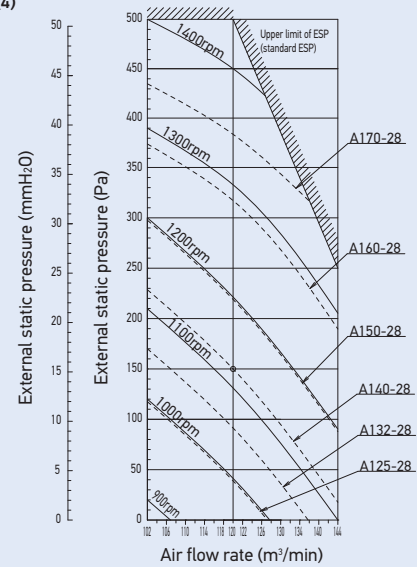

4D064275

FVPR500PY1(4)

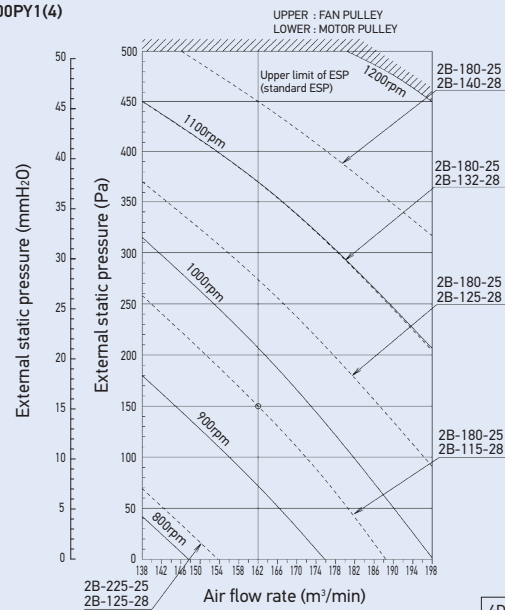

4D064276B

## DUCT TYPE

FDR200PY1(4)  
FDR250PY1(4)

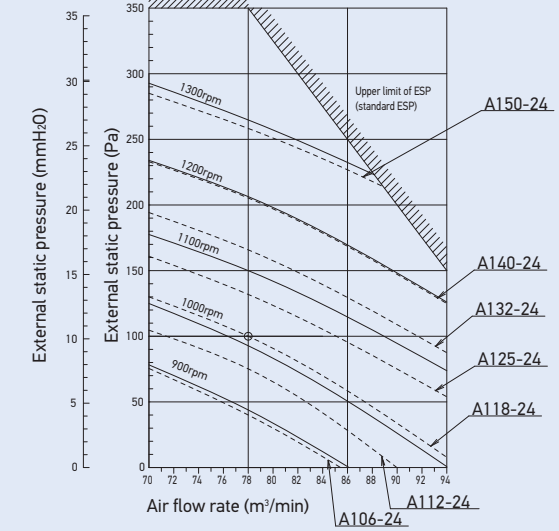

4D064280

FDR400PY1(4)  
FDR500PY1(4)

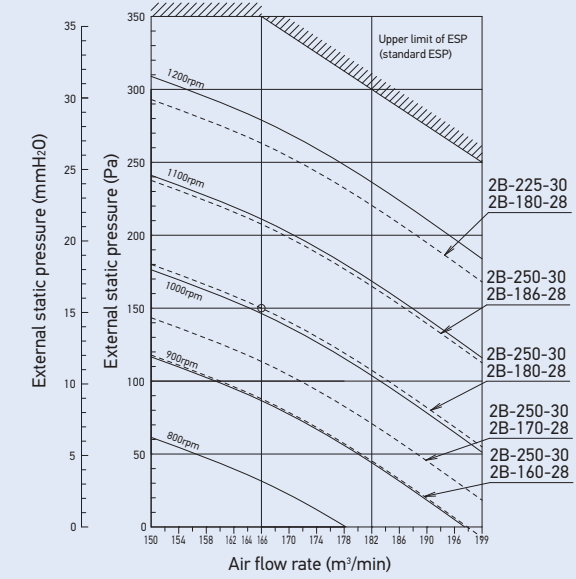

4D064282A

# Wiring Diagrams

## OUTDOOR UNIT

RZUR200PY1(4)

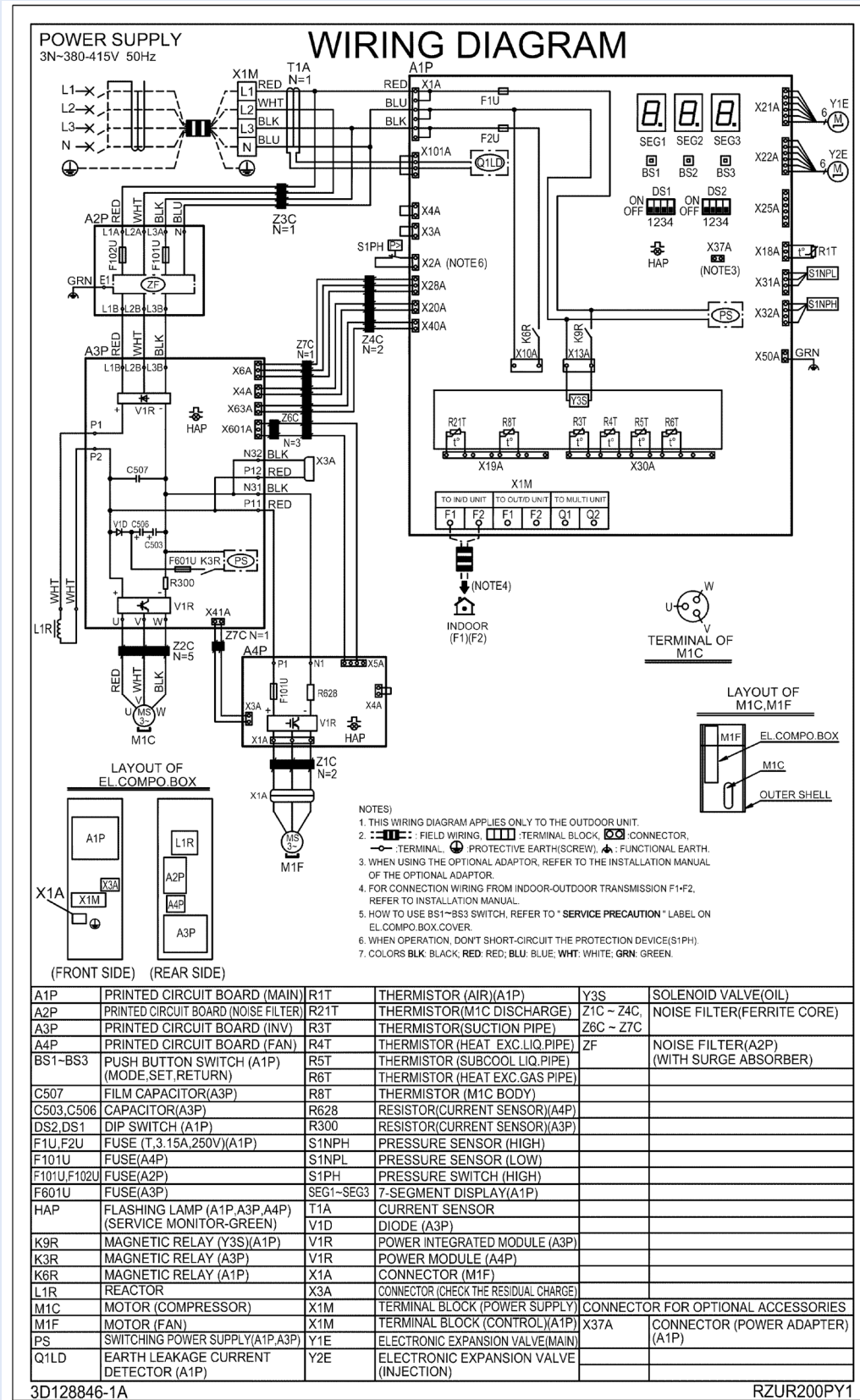

3D128846B

RZUR250PY1(4)

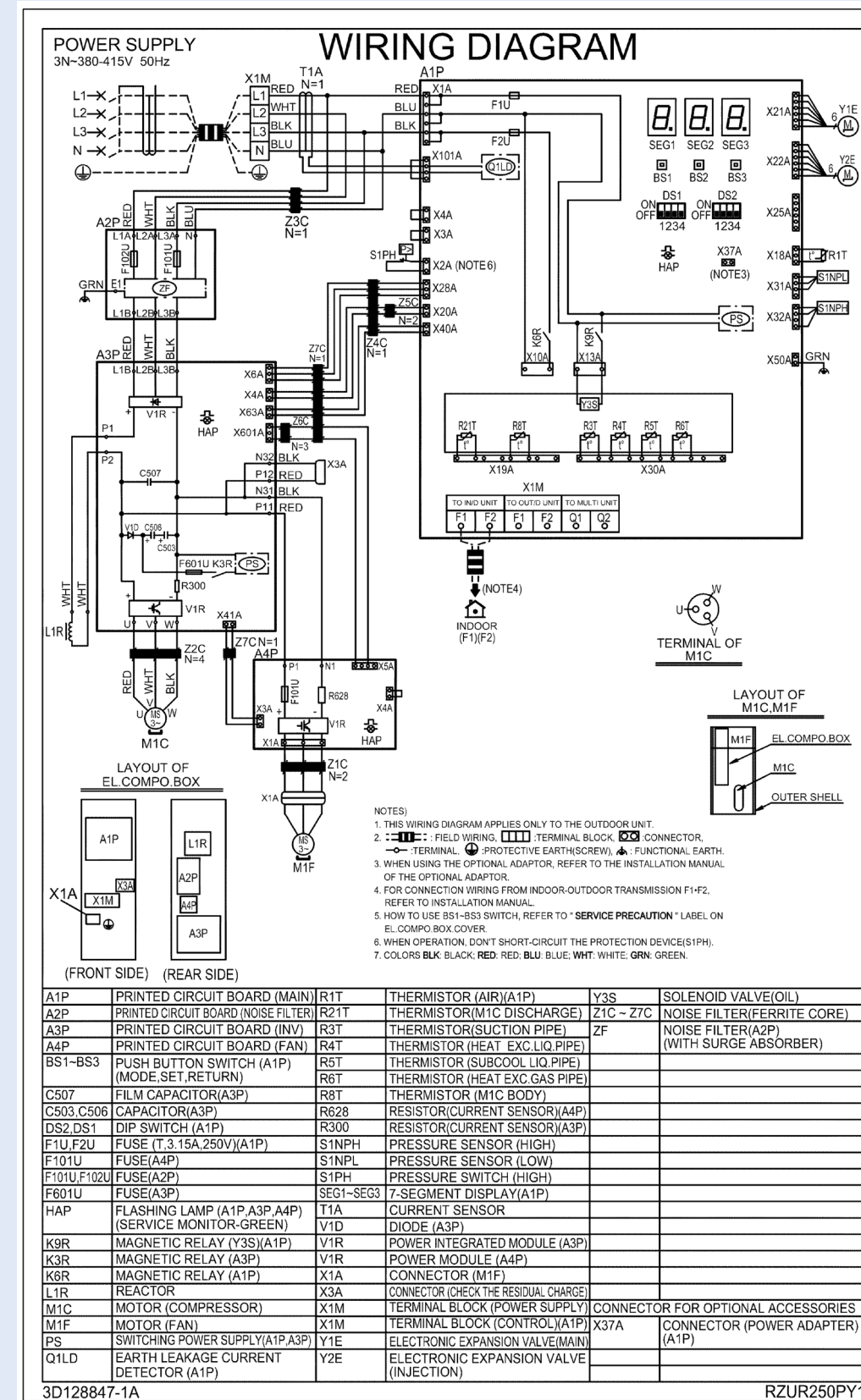

3D128847B



# DIMENSIONS (Unit: mm)

## ■ FLOOR STANDING TYPE

### DIRECT AIR BLOW

FVGR200PV1(4)  
FVGR250PV1(4)

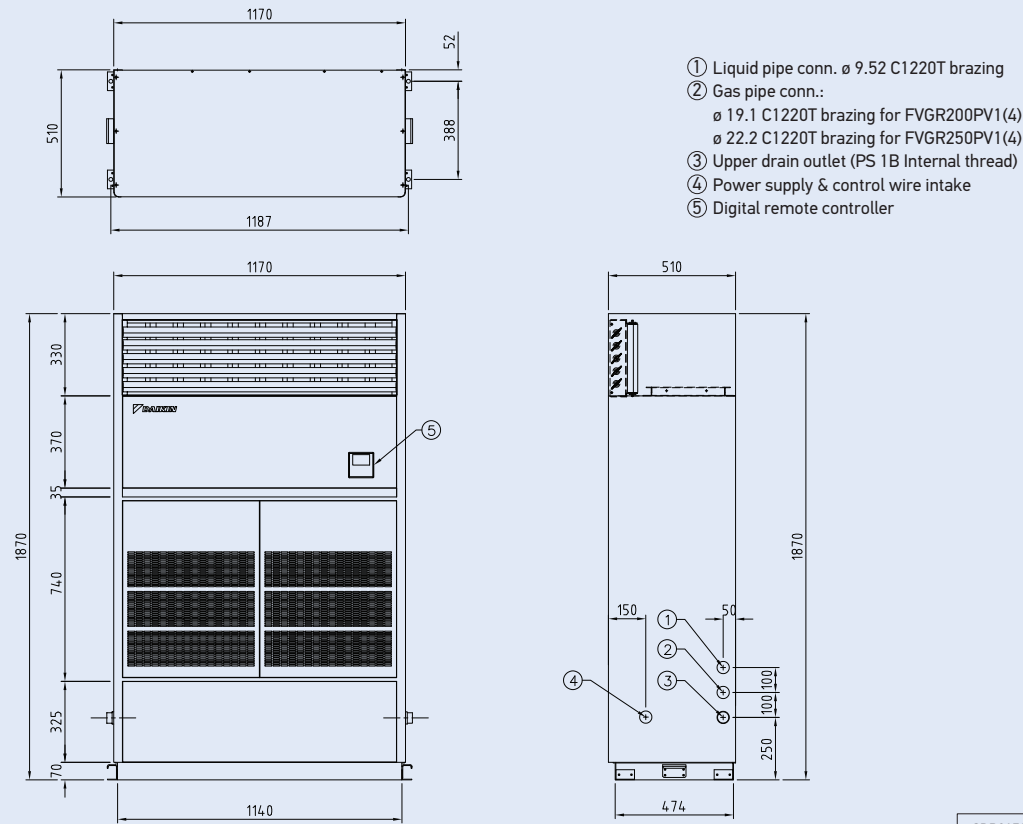

SDR3150202  
SDR3150203

FVPR400PY1(4)  
FVPR500PY1(4)

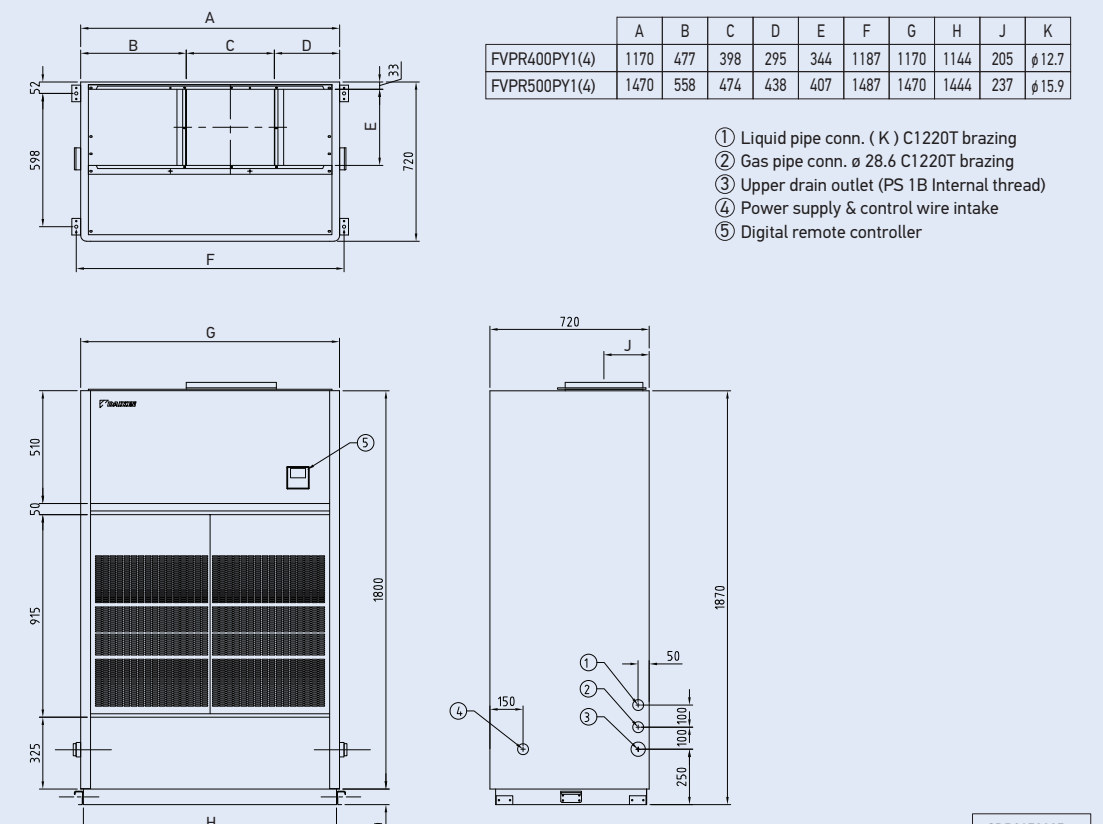

SDR3150205  
SDR3150206

### DUCT CONNECTION

FVPR250PY1(4)

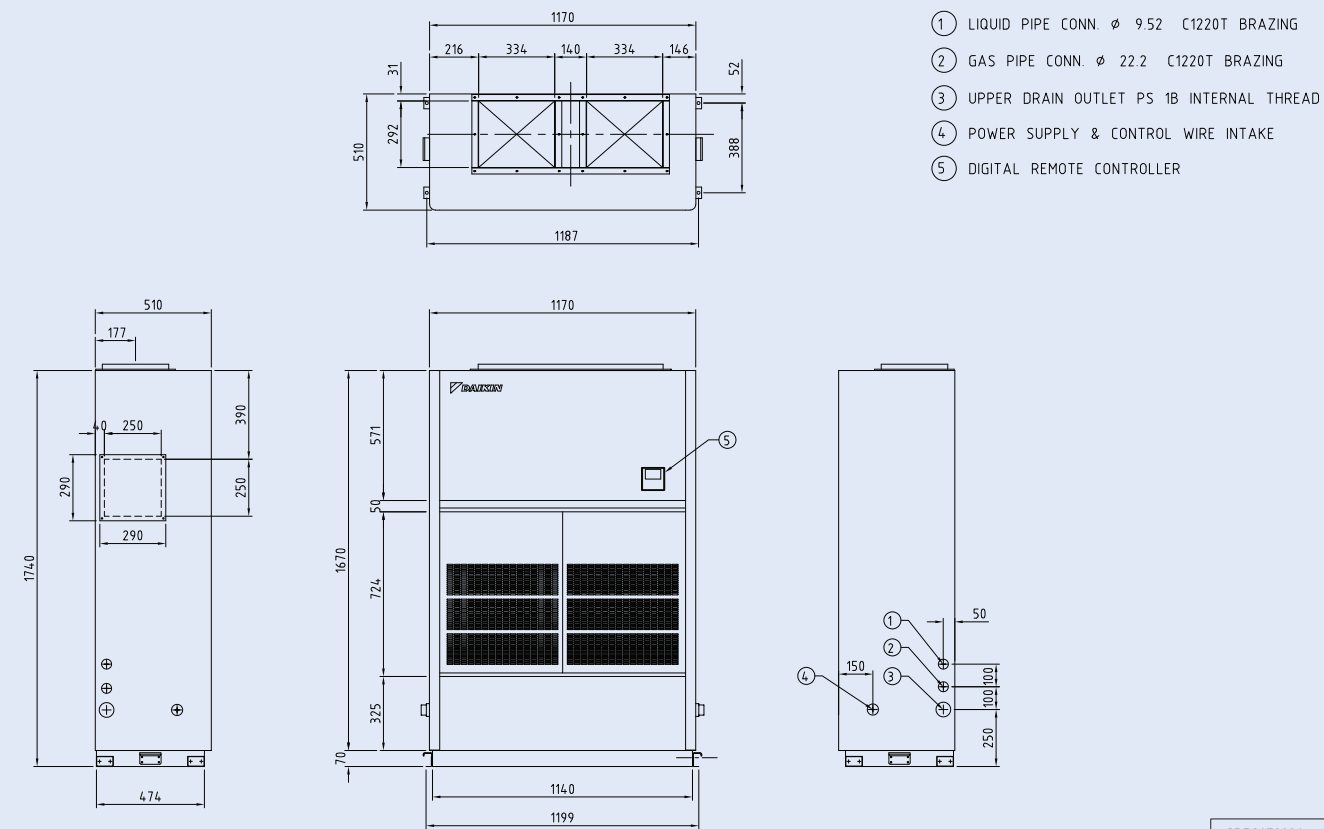

SDR3150204





# Space required for indoor unit installation (Unit: mm)

■ RZUR200PY1(4) / RZUR250PY1(4) / RZUR400PY1(4) / RZUR500PY1(4) (Please refer to engineering databook for other installation patterns.)

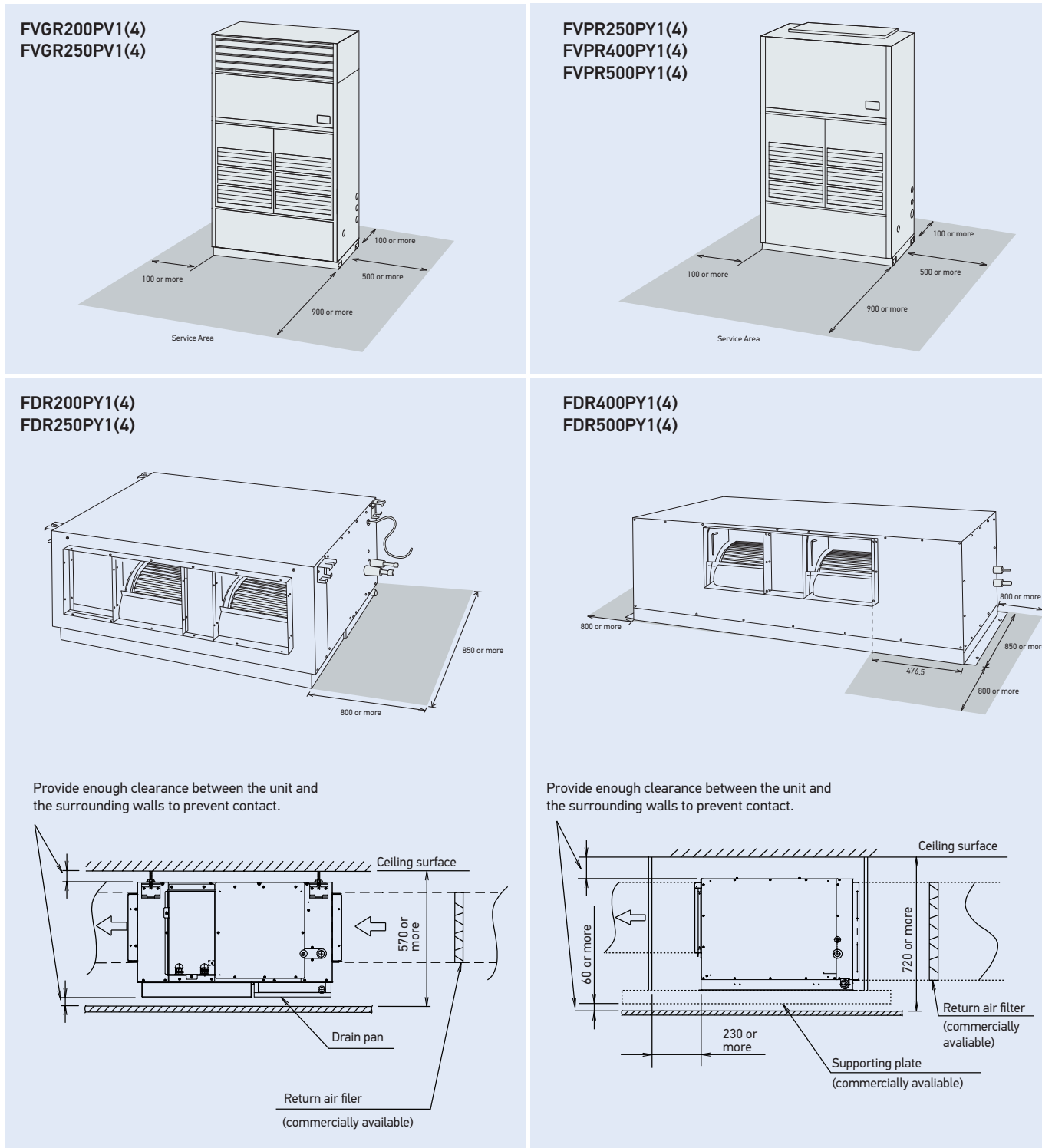

## For single unit installation

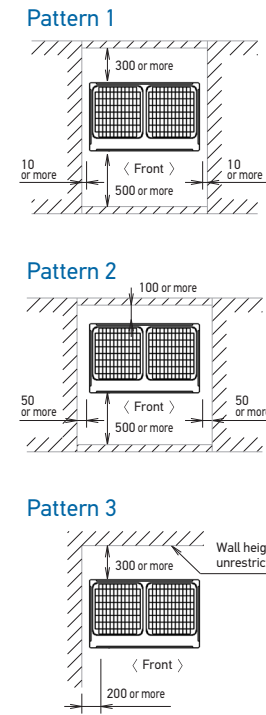

## For installation in rows

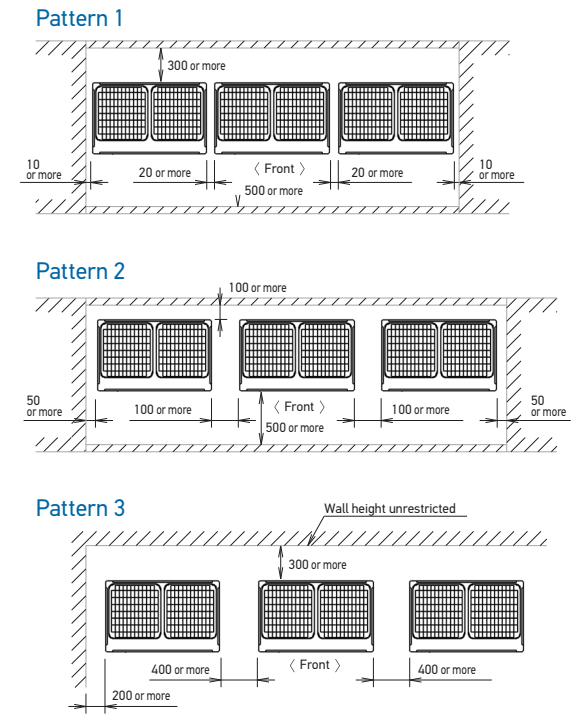

## For centralized group layout

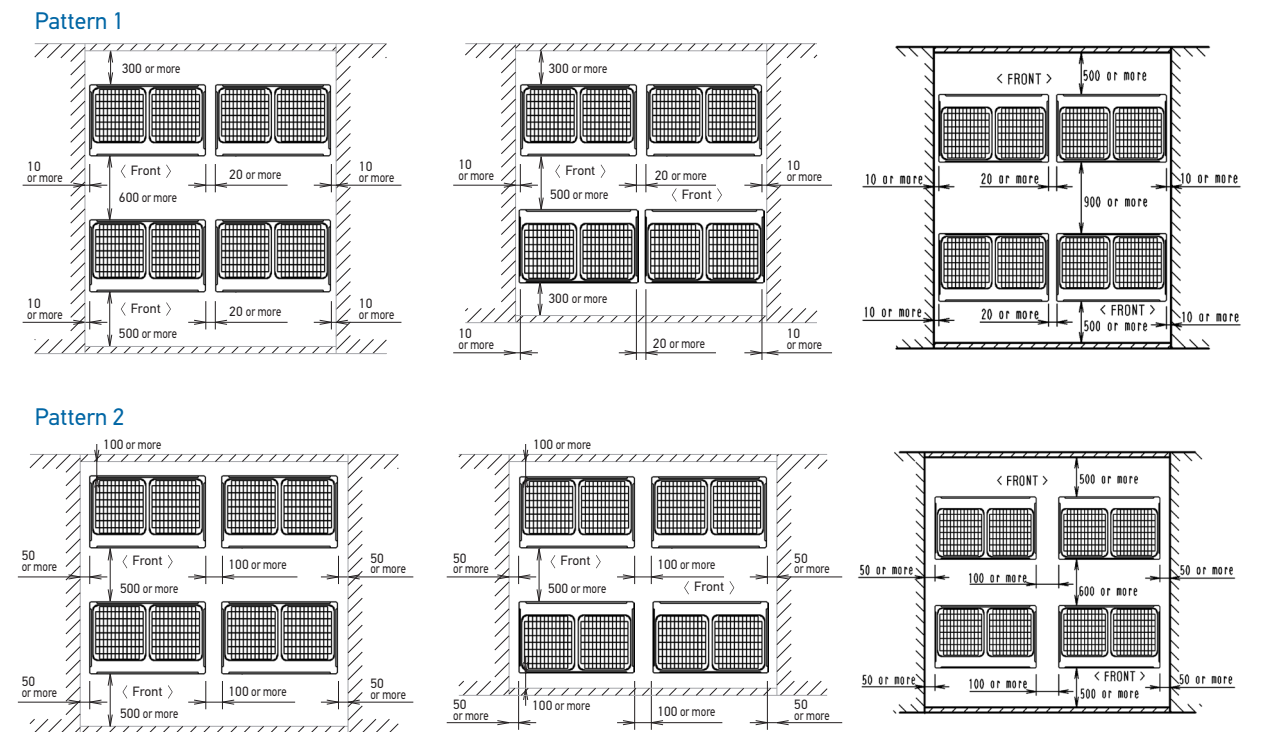

### Notes:

- Heights of walls in case of Patterns 1 and 2:  
Front : 1500 mm  
Suction side : 500 mm  
Side : Height unrestricted.

- Installation space to be shown in this drawing is based on the cooling operation at 35 degrees outdoor air temperature. When the design outdoor air temperature exceeds 35 degrees or the load exceeds maximum ability because of much generation load of heat in all outdoor unit, take the suction side space more broadly than the space to be shown in this drawing.
- If the above wall heights are exceeded then h2/2 and h1/2 should be added to the front and suction side service spaces respectively as shown in the figure on the right.
- When installing the units most appropriate pattern should be selected from those shown above in order to obtain the best fit in the space available always bearing in mind the need to leave enough space for a person to pass between units and wall and for the air to circulate freely.  
( If more units are to be installed than are catered for in the above patterns your layout should take account of the possibility of short circuits. )
- The units should be installed to leave sufficient space at the front for the on site refrigerant piping work to be carried out comfortably.

