

Technical Handbook

Ventilation



Contents

Foreword	5
1. Why ventilation	6
1.1 Health	6
1.2 Comfort	7
1.3 Productivity	7
1.4 Safety	8
1.5 Energy	9
1.6 ECO-design and environmental aspects	10
2. Ventilation systems	11
2.1 Supply	11
2.2 Exhaust	11
2.3 Balanced	11
3. Physics of airflow	13
3.1 The incompressible medium	13
3.1.1 Gas equation	13
3.1.2 Dependencies of air density	13
3.2 State variables of an ideal flow	13
3.2.1 Bernoulli equation	13
3.3 Continuity equation	14
3.4 Definition of the pressures	14
3.4.1 Static pressure	14
3.4.2 Dynamic pressure	14
3.4.3 Total pressure	14
3.5 Pressure loss	15
3.6 System curve (system characteristics)	17
3.7 Velocity distribution in the duct	17
3.8 Pressure measurement in situ	18
4. Acoustics	19
4.1 Noise	19
4.2 Basic principles of sound	19
4.3 Sources of sound	20
4.4 Adjustment to the ear	20
4.5 Several sound sources	21
4.6 Acoustical similarity laws for fans	21
4.7 Silencers	22
4.8 Sound in airways	22
4.9 Sound power level and sound pressure level in situ	24
5. Basic of fans	25
5.1 What is a fan	25
5.2 Types of fans	25
5.3 Axial fan	26
5.3.1 Construction and function	27
5.3.2 Types of axial fans	28
5.4 Radial fan	30
5.4.1 Construction and function	30
5.4.2 Types of radial impellers	31
5.4.3 Configuration of radial fans	30
5.4.4 Special design and special constructions	32
5.4.5 Dust and wear operation	34
5.5 Diagonal fan	35
5.5.1 Construction and function	35
5.6 Crossflow fan	36

5.6.1	Construction and function	36
5.7	Installation of fan and rotating stall	37
6.	The fan in the system.	37
6.1	Characteristic diagrams, general	37
6.2	System and fan curves	38
6.2.1	Inlet and outlet disturbances	38
6.2.2	Diffusors	41
6.3	The laws of similarity	43
6.4	Dimensionless parameters	44
6.4-01	Efficiency	44
6.4-02	Pressure coefficient	44
6.4-03	Airflow coefficient	44
6.4-04	Power coefficient	45
6.4-05	Diameter coefficient	45
6.4-06	Run number	44
6.4-07	Throttle coefficient	44
6.5	Selection criteria	45
6.6	Parallel connection of fans	47
6.7	Series connection of fans	49
6.8	Fan in the system (vibrations)	50
6.9	Pressure measurement in the system	51
6.10	Airflow measurement in the system	54
6.11	Influence of medium density	55
7.	Controlling fans	56
7.1	Remarks, general	56
7.2	Throttle control	57
7.3	Speed control	57
7.4	Blade control	58
7.5	Vane control	59
7.6	Bypass control	60
8.	Drive design	61
8.1	Electrical and mechanical energy	61
8.2	Motors, direct drive	63
8.3	V-belt drive	65
8.4	Coupling	66
8.5	Speed control	67
8.6	Control technology	68
9.	System controls monitoring	71
9.1	Monitoring the system pressure	71
9.2	Monitoring the airflow	71
9.3	Monitoring the drive motor	73
9.4	Vibration monitoring	73
9.5	Monitoring of temperature and humidity of the medium	74
9.6	Sound measurements	74
10.	Special fans (safety-relevant devices)	75
10.1	Equipment fire safety	75
10.2	Explosion protection	77
10.3	Explosion protection – protection against aggressive gases	81
11.	Formulas	87
12.	Sources	91
13.	Index	92

Foreword

Ventilation has a very relevant and central role in modern society. Both new and existing researches show that the quality of the indoor climate plays a crucial role in our health and well being, while energy efficiency has become an area of focus in most countries. Because of this, high demands are placed on both the components and the technical designs of system solutions to ensure energy efficiency as well as an optimal indoor climate.

At Systemair, we spend over 450,000 design hours every year developing new and improved ventilation products, designed to meet current and future demands for energy efficient and safe system solutions. This handbook covers some of the technical areas that Systemair operates in.

The aim of this handbook is to give an insight into Systemair's expertise within system solutions, applications, ventilation theories and products.



Mats Sándor

Technical Director

Systemair AB

1. Why ventilation

Studies show that ventilation is essential for our health and well-being. Increasing energy costs, new regulations demanding lower energy consumption and well-insulated houses make it important to choose the correct ventilation system.

The conflict between energy and a good indoor environment is that ventilation is necessary to create a good indoor environment and ventilation needs energy to function.

For the future, one key issue is how to reduce energy consumption and improve indoor air quality.

Indoor climate

The purpose of ventilation is to enable us to breathe clean air by removing the stale, polluted air from our environment and replacing it with good quality air. By doing this we create healthier indoor conditions, better performance and excellent comfort.

Human beings eat approximately 1 [kg] solid food, drink approximately 3 [kg] fluids and breathe approximately 15 [kg] of air per day and person. We spend around 90 [%] of our time indoors yet we are more concerned about food and drink than the surrounding air.

There are several studies showing that clean indoor air is essential.

1.1 Health

The Värmland Study

The study was started in 2000 by Professor Jan Sundell at Denmark's Technical University, and Dr Carl-Gustaf Bornehag at the University of Karlstad and The Swedish National Testing and Research Institute, SP.

All families in Värmland, Sweden with children between the ages of one and six received a questionnaire in the mail; a total of 14 000 questionnaires were sent out. Almost 9 000 of these families responded to the questions asked by the researchers. Within the 9 000 families, there were 11 000 children, making this survey by far the biggest study in the world on how the indoor environment affects children's health.

To get further results, four hundred children (200 healthy, 200 with severe allergies or asthma) were selected for an in-depth study regarding the connection between indoor environment and illness.

So far, researchers have concluded that ventilation has a significant impact on children's health. A good air exchange rate does not remove the risk for asthma or allergies but children living in well-ventilated homes have a better chance of staying healthy.

This is an ongoing study with the official name "Dampness in Buildings and Health".

The Bamse Study

Another Swedish study pointing in the same direction as the Värmland Study is the Bamse Study. It is a study on children's allergies carried out in Stockholm. Over 4000 children from Stockholm born between 1994 and 1996 were followed from birth. The Bamse Study is a co-operation between The Department of Occupational and Environment Health, The Astrid Lindgren's Children's Hospital and the Institute for Environmental Medicine at the Karolinska Institute. The children and their living environment were checked regularly.

In the Bamse Study the researchers concluded, among other things, the following:

- A poor indoor climate (mould / dampness / condensation) in our homes increases the risk of asthma
- Smoking during pregnancy leads to an increased risk for children to develop asthma
- Breastfeeding decreases the risk of children developing asthma

Among children exposed to two or three risk factors (tobacco smoke, poor indoor climate, prematurely interrupted breastfeeding) the risk of developing asthma was more than twice compared to children exposed to one, or none, of these risks.

At the age of four, 40 percent of the children had some form of allergy, i.e. asthma, skin rashes, hay fever or food allergies.

1.2 Comfort

We feel at ease when there's clean fresh air around us. Using ventilation to create comfort and well-being leads to better health, productivity and mood.

It should be equally clear for anyone to ensure our homes and offices are ventilated, purified with properly tempered demand-controlled air, same as our modern cars and all the other places where we are spending our time.



1.3 Productivity

To create good conditions for optimum performance, the indoor climate is an important factor.

Temperature is critical to our performance. At 27 [°C] we are performing only 70 [%] of our normal capacity (fig. 1.1).

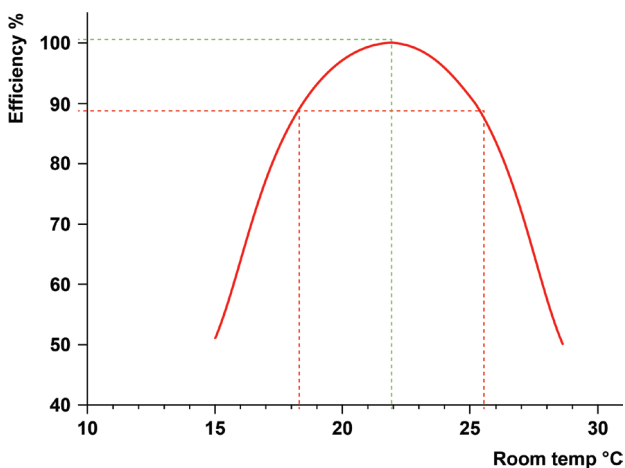

Fig. 1.1. Study from DTU

Several studies reveal a relationship between ventilation flow rates and sick leave (fig. 1.2). With increased airflow reducing absenteeism.

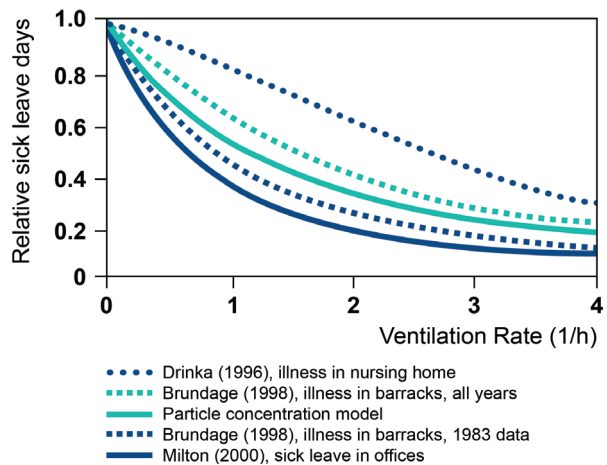

Fig. 1.2. Fish W, Seppänen, Faulhkner, Haug

The operating cost of ventilation in a typical office building is under 1 [%] of the office labour cost. This makes it profitable to create a good indoor climate with well-functioning and properly sized ventilation systems in office buildings (fig. 1.3).

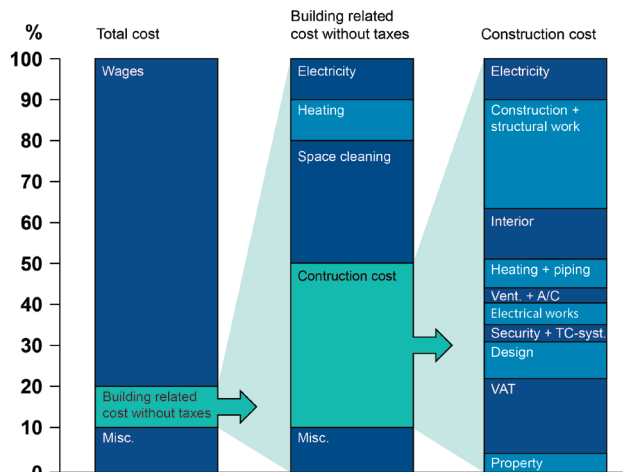

Fig. 1.3. REHVA Guidebook No 6 – 2006

1.4 Safety

Safety is an important aspect of the design and construction of buildings. Architects, engineers and other stakeholders have to minimize the danger of injuries and illnesses for the occupants, because of unsafe or unhealthy building designs, and the danger of damages to the property due to disasters.

Operational, technical and physical safety methods have to be applied, to protect the occupants, the building itself and the assets inside.

Protection against heat and smoke

Fire safety is subdivided into preventative fire safety, organisational fire safety and protective fire safety. Here, the individual measures of the fire safety concept must be coordinated with each other, so that a smooth interaction of the measures is ensured.



Preventative fire safety

Preventative fire safety is understood to be all those precautions which, with a fire, counteract the spread of the fire, enabling people and animals to be rescued and property to be salvaged—and to provide the prerequisites for effective firefighting.

Individually, these are measures for

- Structural fire safety
- Equipment fire safety

Structural fire safety

Structural fire safety includes the sum of all, structural design and function plan measures, which reduce to a minimum – or completely or temporarily prevent – the spread and transmission of a fire; enabling people to be rescued, to ensure firefighting activities are safe for a certain period, and to keep the destruction and extent of damage to buildings, plant and equipment to a minimum.

Protection against explosion

Explosion protection is an area of technology concerned with protection from the formation of explosions and/or limiting their effects. The field of work comes under the heading of safety engineering and serves to prevent damage to people, property and the environment by technical products, plant and equipment. In individual cases, explosion protection is realised using technical solutions and legal requirements.



In order for there to be an explosion, the three components “flammable material in a finely distributed form”, oxygen and an ignition source must all come together. These components can be represented as a so-called “explosion triangle”. An explosion cannot take place if one of these three components is missing.

Therefore, to ensure explosion protection, there are three principal approaches:

- Avoidance or enclosure of the ignition source
- Avoid flammable materials in a potentially explosive form
- Inertisation (removal of oxygen)

Ignition sources are, for example, hot surfaces, electrical discharges, mechanically generated sparks, shock waves, etc.

Protection against aggressive media

The chemical resistance of elastomers, plastics and metals used in plant engineering (fans) is very varied and also dependent on many factors. These include the temperature of the conveyed medium, the concentration, contamination, the addition of undesired solid or gaseous accompanying materials, and the effects of mechanical forces such as static or dynamic loads.

These factors influence, for example, the metallic corrosion behaviour and the chemical resistance of the polymeric materials.

The data given in the resistance tables is therefore only a recommendation for which no liability can be assumed.

Detailed information concerning the resistance of materials used can be found in the resistance lists of the material manufacturers. With critical media, a written enquiry stating all conditions of use is essential.

No warranty claims or guarantee claims can be derived from the chemical resistance data listed. The application-specific selection of materials, the use, application, and processing of the products purchased is only the responsibility of the user.



1.5 Energy

Low energy ventilation

Some factors contributing to low power consumption in ventilation systems are:

Energy-efficient fans

EC-fans (fig. 1.4) have a typical saving potential of 20-50 percent compared to AC-fans.

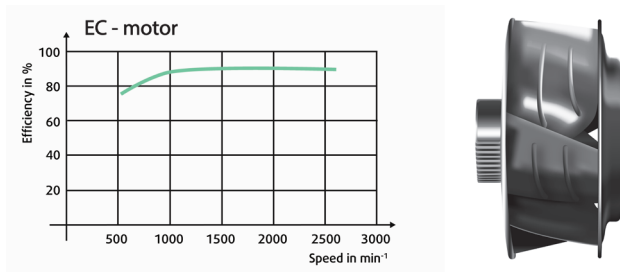

Fig. 1.4. EC-fans (source: ebm-papst)

The EC-fan is an Electronic Commutated DC-motor with the characteristic of maintaining a high efficiency when speed-controlled.

Low pressure drop

The pressure drop in ventilation systems and ventilation products is essential for overall energy consumption.

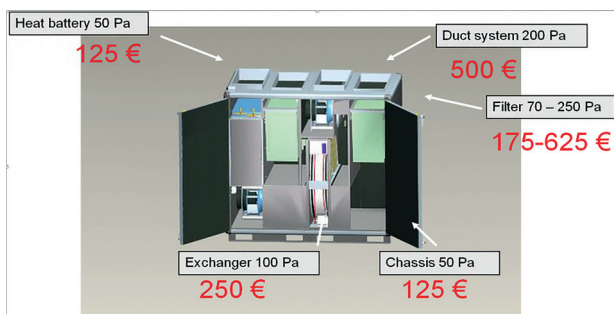

Fig. 1.5. With a simple calculation, the annual cost for an air handling unit (in Europe with an average cost of 0,143 €/kWh) with a capacity of 1 m³/s is about 2.5 €/Pa. The pressure drops over the filter are normally 70 Pa for a clean filter and 250 Pa for a dirty filter. The annual cost is then between 175 to 626 €/year just for the filter. This indicates it is cost-effective to exchange dirty filters.

Modern ventilation systems have low velocities in the duct system and few or no dampers.

Operating point

It is crucial that the fan in the system is operating near or at the optimum operating point. It is a mistake to only look at one fan's highest efficiency. Modern fans are specially designed to have high efficiency at the designed operating point. This is evident for fans designed for low-pressure systems.

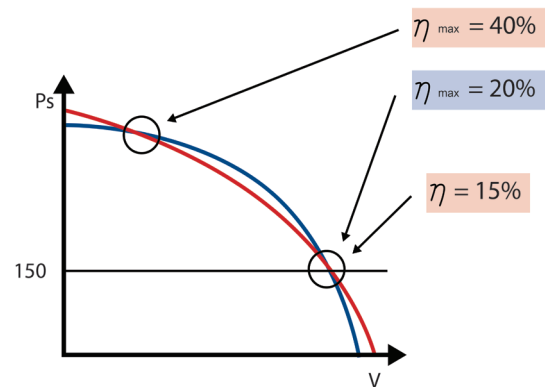

Fig. 1.6. Working point - efficiency

In the example (fig. 1.6), the maximum efficiency for the red fan is 40 [%] and for the blue fan 20 [%]. In the working point at 150 [Pa] the blue fan is more efficient.

Demand control ventilation

With demand control ventilation, the ventilation is only used when necessary and with the appropriate amount.

The ventilation could be controlled by temperature, humidity, carbon dioxide, an occupancy sensor, a timer or manually.

Examples of applications are:

- Changing rooms with showers
- Laundry rooms
- Shops with a great variation in numbers of customers
- Conference halls, theatres
- Assembly halls
- Gymnasiums and training halls
- Shops, restaurants
- Offices, day-care centres, schools

Heat or energy recovery

With a recovery system, the savings are normally essential. Typical recovery is between 50 to 90 [%] of the energy in the transported air.

Building management system

With a building management system, it is possible to optimize the system to be highly energy-efficient, ensuring functionality.

1.6 ECO-design and environmental aspects

Eco-Design

Eco-design requires products to deliver a certain level of energy efficiency if they are to be used in the EU. The Eco-Design Directive was adopted by the EU in 2005. The aim is to reduce the environmental impact of energy-consuming products and so help move towards more sustainable development. It is a framework directive that encompasses basically all energy-consuming products other than modes of transport. Air-conditioning, air curtain and fan products make up one of 14 product categories to be scrutinised. Other categories include lighting, washing machines and dishwashers, electric motors, refrigerators, TV sets, etc.

Energy Declaration

EU energy declaration rules require a statement to be issued for buildings, showing how much energy is needed to heat the building, any air-conditioning and electric power needed to operate fans and lifts, for example. An energy declaration must be issued for all buildings with a “right of use”, for example, buildings with owner-occupied or rented apartments. To achieve these goals, regulations concerning both existing and new buildings are continually being tightened. It will become necessary to build more and more “climate-smartly”. Climate-smart buildings are energy conserving buildings that mainly use renewable energy, or they are “passive houses” that dispenses with traditional heating systems. These air-tight buildings place great demands on efficient ventilation to prevent mould and damp.



2. Ventilation systems

Three main kinds

Natural

- Uses no fans, only thermal forces like chimney effect

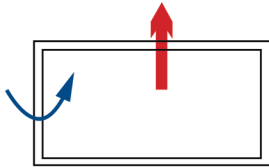

Mechanic extract

- Fans extracting air

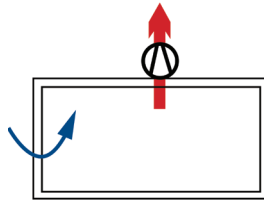

Balanced

- Same as mechanic but also has fans for supply. Often supplied with heat exchanger

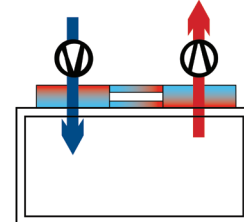

2.1 Supply

Replace polluted indoor air with fresh outside air. Establish a level of e.g. CO₂ so the quality of the indoor air is enough for its purpose.

2.2 Exhaust

(LOT 10 definitions)

Building ventilation can be roughly divided into three categories: natural ventilation, local mechanical ventilation (room by room) and central mechanical ventilation (various rooms). Each kind of ventilation requires specific energy using products. Mechanical ventilation includes all the motorized devices used to renew the indoor air. Hybrid ventilation systems are defined in EN12792 (under discussion for modification) as “ventilation where natural ventilation may be at least in a certain period supported or replaced by powered air movement component” to enlarge the notion not only to the fans but to the full building which has to be designed in a certain way. Mechanical ventilation is associated with the presence of fans.

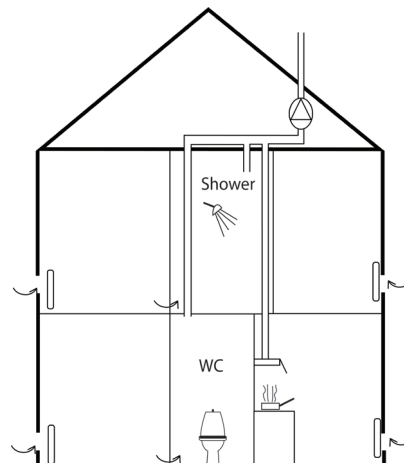

2.3 Balanced

Balanced double flow ventilation system

The double flow balanced system is made with (following the flow): air collection (outside the building), one fan, air inlets into the room, extraction devices, another fan, air extract device, with typically the addition of a heat exchanger and some filters, and ducts to conduct air flows (inlet and exhaust). The flow becomes almost independent from outside pressure conditions. The internal pressure balance becomes even more important.

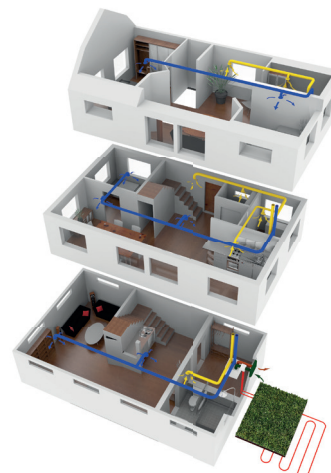

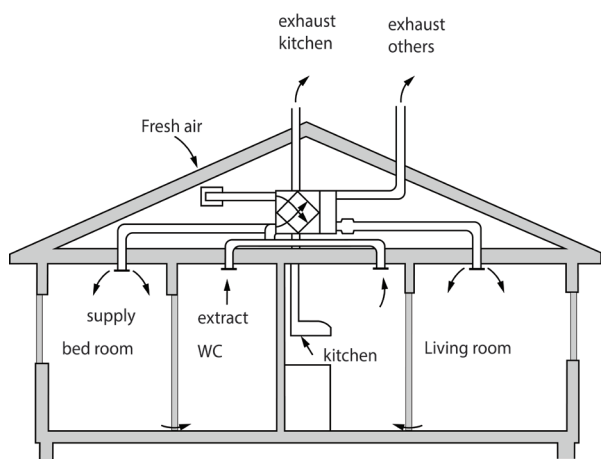

Balanced or double flow centralized mechanical ventilation.

The extract air is extracted in the kitchen, the toilets and the bathrooms. New air is introduced in other rooms with another network but the same extractor block. The extract air is extracted in the kitchen, the toilets and the bathrooms. New air is introduced in other rooms with another network but the same extractor block.

Centralization allows to process the new air (filtration, heating, humidification ...) and by gathering the two networks (extraction of stale air and extraction of new air) to preheat the new air by recovering heat on the extracted air thanks to a plate heat exchanger. As a result, double flow ventilation coupled with heat recovery heat exchanger enables to economize heating energy.

This system enables to recover an important part of the energy lost because of the introduction of fresh air for ventilation need in winter but increases electricity use in the product. Double flow heat recovery ventilation is a stand alone product to be installed on the ventilation network in dwellings. The head losses being different, the electricity use cannot be compared directly with the other products.

Centralized mechanical ventilation systems can become the basis of a reversible heat pump system that uses extract air as the cold source in winter and as the hot source in summer. This space heating system can be called "balanced flow thermodynamic ventilation". It supplies both cooling in summer and heating in winter but the heating and cooling energy does not enable to cover all the heating and cooling needs because ventilation air flow rates are quite small. As for plate heat exchanger, heat or cool recovered will depend on outside conditions. This system enables to recover from 50 [%] to 200 [%] of the energy lost because of the introduction of fresh air for ventilation need in winter and in summer according to (Promotelec, 2006). Both in cooling and heating modes, this system can only supply part of the thermal requirements of a standard dwelling. It is covered by EPBD consistent.

Natural ventilation

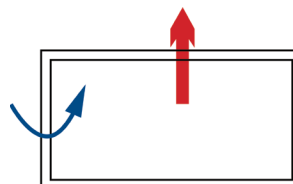

Typical natural stack ventilation system. Air naturally comes into the building through cracks, slots trickle ventilators or other devices and exists through vertical ducts. Air motion is due to temperature difference or wind or both.

Fan assisted exhaust ventilation

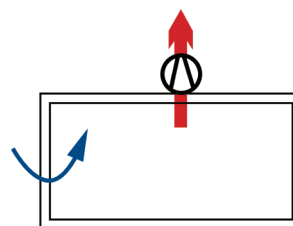

Natural supply and mechanical extract system. Air naturally comes into the building through cracks, slots, trickle ventilators or other devices and is mechanically driven out through a central exhaust duct system.

Fan assisted supply ventilation

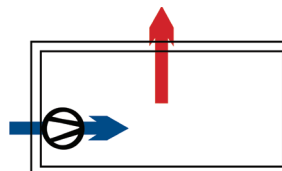

Mechanical supply system. Air is supplied to the building by a fan and naturally leaves the building through cracks, slots or other devices.

Fan assisted balanced ventilation

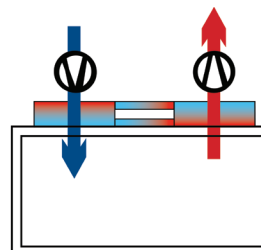

Mechanical supply and extract system. The air is mechanically supplied and extracted through two separate ducted systems. The air handling units include a heat recovery unit to recover energy from the outgoing stream.

3. Physics of airflow

Basic physical quantities

Symbol	Description	Value	Dimension
V	Airflow		[m³/s]
m	Massflow		[kg/s]
p _s	Static pressure		[Pa]
p _d	Dynamic pressure		[Pa]
p _t	Total pressure	= p _d + p _s	[Pa]
p _a	Atmospheric pressure	= 101325	[Pa]
p _h	Pressure at the height H _a		[Pa]
ρ	Density of the air		[kg/m³]
η	Efficiency		[%]
R	Gas specific constant for air	= 287.058	[J/kg·K]
T	Absolute temperature		[K],[°C]
u ₂	Blade tip speed		[m/s]
A	Cross section area		[m²]

Symbol	Description	Value	Dimension
g	Gravitational acceleration	= 9,81	[m/s²]
H _a	Geodesic height		[m]
D	Diameter		[m]
D _h	Hydraulic diameter		[m]
l	Duct length		[m]
U	Perimeter		[m]
λ	Friction factor		[-]
ζ	Resistance coefficient		[-]
L _p	Sound pressure level		[dB]
L _w	Sound power level		[dB]
A _{eqv}	Equivalent absorption area		[m²Sabine]
P _w	Shaft power		[W],[kW]
J	Moment of inertia		[kg·m²]
n	Speed of rotation		[min⁻¹]

3.1 The incompressible medium

Basics of fluid mechanics

The incompressible medium

The gaseous flow medium of ventilation and air-conditioning technology is air.

The properties are determined by the state variables.

Temperature T [K], gas specific constant R [J/kg·K], pressure p [Pa], viscosity ν [Pa·s] and density ρ [kg/m³], are the most important state variables of air. Air at normal conditions can be considered as an ideal gas with sufficient accuracy.

The relationships between the state variables and the material properties are described by the gas equation.

3.1.1 Gas equation

eq. 3.1.1-01

$$\rho = p_1 / (R \cdot T)$$

Air density. From the gas equation, the density ρ₀ at t = 0 [°C] at sea level and an average atmospheric pressure of

p_a = 101 325 [Pa] is given by

$$\rho_0 = 101\,325 / (287,058 \cdot (273+0)) = 1,293 \text{ [kg/m}^3\text{]}$$

the density ρ₂₀ at t = 20 [°C] at sea level and an average atmospheric pressure of p_a = 101 325 [Pa] (normal air)

$$\rho_{20} = 101\,325 / (287,058 \cdot (273+20)) = 1,204 \text{ [kg/m}^3\text{]}$$

Since the differences in pressure in ventilation and air-conditioning engineering are tiny when compared to the atmospheric pressure, this is disregarded, and air is described as an “incompressible medium”.

3.1.2 Dependencies of air density

- Temperature dependency must be taken into account. According to the gas equation, for two different temperatures at the same pressure.

eq. 3.1.2-01

$$\rho_1 / \rho_2 = T_2 / T_1 \quad \rho_1 = \rho_2 \cdot (T_2 / T_1) \quad \begin{array}{l} \text{Index 1: } 20[^\circ\text{C}] \\ \text{Index 2: } XX[^\circ\text{C}] \end{array}$$

Using the above values to determine ρ₂₀ (air density at 20[°C]) results in:

$$\rho_{20} = 1,293 \cdot (273 / 293) = 1,204 \text{ [kg/m}^3\text{]}$$

- Note:** The values are valid for dry air. The density values for moist air are always somewhat smaller and are generally disregarded. (the values change in the third decimal place)

The total pressure increases (static, dynamic and total) change according to the dependencies in line with the gas equation, as shown in the following formula:

eq. 3.1.2-02

$$\Delta p_{t1} / \Delta p_{t2} = \rho_1 / \rho_2 = T_2 / T_1$$

The drive powers change according to the dependencies in line with the gas equation, as follows:

eq. 3.1.2-03

$$P_{w1} / P_{w2} = \rho_1 / \rho_2 = T_2 / T_1$$

- Altitude dependency.** If a system is working at higher altitudes, the density must be calculated and taken into account as appropriate. The calculation of the density is performed using the internationally agreed altitude formula (for 0 [°C]).

eq. 3.1.2-04

$$p_H = p_a \cdot e^{-H_a/7990} \quad [\text{Pa}]$$

3.2 State variables of an ideal flow

3.2.1 Bernoulli equation

The approach of the Bernoulli equation states that, for an ideal flow, the sum of the static pressure, dynamic pressure and the geodetic pressure is constant at every point in the flow line.

For a horizontal flow, the geodetic pressure can be disregarded in the Bernoulli equation, since it is the same on both sides of the equation.

eq. 3.2-01

$$\rho/2 \cdot c^2 + P_s + \rho \cdot g \cdot H_a = \text{Constant}$$

c - velocity of the air at that point, [m/s];

$g=9,81$ [m/s²] - gravitational acceleration;

H_a - height where element of air is situated, [m];

After disregarding the geodetic pressure, the following results:

eq. 3.2-02

$$\rho/2 \cdot c^2 + P_s = P_d + P_s = P_{\text{total}}$$

As the simple example shows: flow through a duct with a widening cross-section:

See fig. 3.2: Diagram of the flow profile

See fig. 3.2: Diagram of the pressure profile

3.3 Continuity equation

A further basic equation is the continuity equation. This states that the airflow is the same at each point of the unbranched system.

eq. 3.3-01

$$m = \rho \cdot c \cdot A = \text{constant}$$

See fig. 3.3: Continuity diagram

eq. 3.3-02

$$m = \rho \cdot c_1 \cdot A_1 = \rho \cdot c_2 \cdot A_2 ; \quad c_2 = c_1 \cdot (A_1 / A_2)$$

3.4 Definition of the pressures

In a system, a fan must overcome resistance in order for an air volume to move through the system. A difference is made between the various pressures:

3.4.1 Static pressure (fig. 3.4)

The static pressure is the pressure of gas acting on the surrounding walls at right angles i.e. the sum of all resistances in the system.

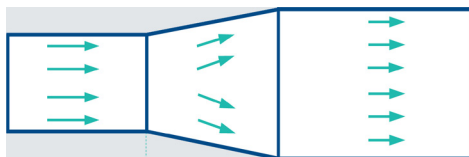

Fig. 3.1. Diagram Flow profile

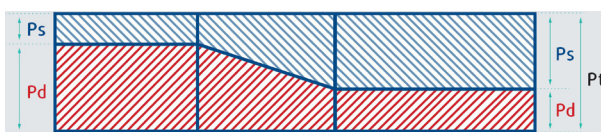

Fig. 3.2. Diagram Pressure profile

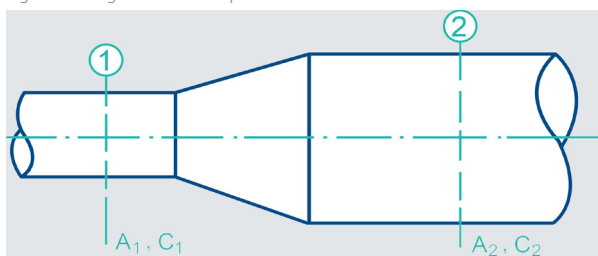

Fig. 3.3. Continuity diagram

This sum consists of the individual resistances, such as the surface roughness of the duct, fittings, grids, flaps, heat exchangers, outlets, etc.

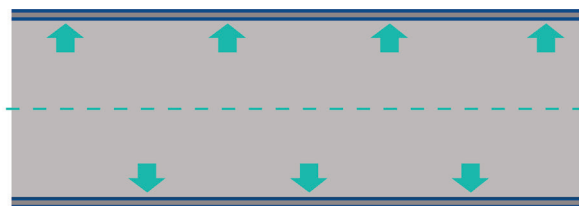

Fig. 3.4. Diagram – static pressure

3.4.2 Dynamic pressure (fig. 3.5)

The dynamic pressure is the energy of the flowing gas due to its motion, i.e. the kinetic energy. The effect is usually parallel to the duct wall on the obstacles hindering the flow.

The following applies for the dynamic pressure at any measurement point in a system:

eq. 3.4.2-01

$$p_{d1} = \rho/2 \cdot c^2 \quad [\text{Pa}]$$

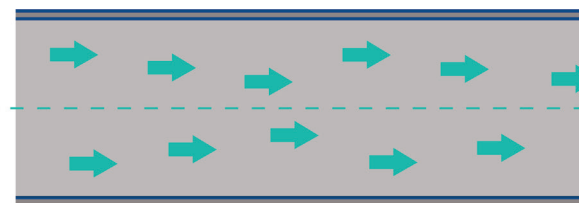

Fig. 3.5. Diagram – dynamic pressure

3.4.3 Total pressure

The total pressure p_t is the sum of all static pressures and the dynamic pressure (can be measured for example with Prandtl tube (fig.3.6)).

eq. 3.4.3-01

$$p_t = p_s + p_d$$

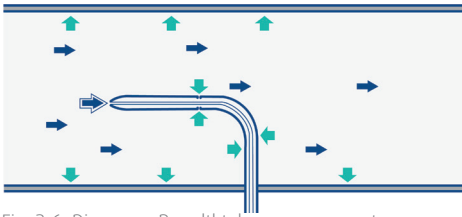

Fig. 3.6 Diagram – Prandtl tube measurement

[Pa]

- Basic principles regarding the pressures in suction and pressure ductlines. All the different types of pressures are prefixed either by a + or a - sign.

Negative on the suction side of the fan, positive on the pressure side. i.e. they are differential pressures against the atmosphere – whereby the atmospheric pressure p_a must be treated as a reference!

3.5 Pressure loss

In real flows pressure losses occur, which must also be overcome by the fan.

- **Resistance can occur due to the friction or separation of flow.** This pressure loss is caused by friction of the flowing gas.

The following applies for round ducts:

eq. 3.5-01

$$\Delta p_v = \lambda \cdot (l / d) \cdot p_d$$

For ducts with any cross-section the following applies:

eq. 3.5-02

$$\Delta p_v = \lambda \cdot (l / d_h) \cdot p_d$$

eq. 3.5-03

$$d_h = 4 \cdot (A / U)$$

- λ : Friction factor
- l : duct length[m]
- d : duct \varnothing [m]
- d_h : hydraulic \varnothing [m]
- A : Cross-section[m²]

For a rectangular duct with a + b:

eq. 3.5-04

$$\Delta p_v = \lambda \cdot (l \cdot (a+b) / 2 \cdot a \cdot b) \cdot p_d \quad [\text{Pa}];$$

eq. 3.5-05

$$d_h = 2 \cdot a \cdot b / (a + b)$$

The following applies for round ring ducts:

d_1 : Internal \varnothing [m]

d_2 : External \varnothing [m]

eq. 3.5-06

$$\Delta p_v = \lambda \cdot (l / (d_2 - d_1)) \cdot p_d \quad [\text{Pa}]$$

λ -values can be found, for example, by using the Moody Diagram (these are dependencies of the friction factor from roughness (table 3.2) of the duct walls and the Reynolds number).

<table border="1"> <tr><td>OR/D=0,5</td><td>0,75</td><td>1,0</td><td>1,5</td><td>2</td><td>3</td><td>4</td></tr> <tr><td>$\zeta = 0,9$</td><td>0,43</td><td>0,33</td><td>0,24</td><td>0,19</td><td>0,17</td><td>0,15</td></tr> </table>	OR/D=0,5	0,75	1,0	1,5	2	3	4	$\zeta = 0,9$	0,43	0,33	0,24	0,19	0,17	0,15	<table border="1"> <tr><td>h/b</td><td>0,25</td><td>0,5</td><td>1,5</td><td>2,0</td></tr> <tr><td>ζ</td><td>2,1</td><td>1,7</td><td>1,2</td><td>0,6</td></tr> </table>	h/b	0,25	0,5	1,5	2,0	ζ	2,1	1,7	1,2	0,6	$\zeta = 1,4$	<table border="1"> <tr><td>$W_2 / W_1 =$</td><td>0,4</td><td>0,6</td><td>0,8</td><td>1,0</td><td>2,0</td><td>3,0</td></tr> <tr><td>$\alpha = 60^\circ$</td><td>5,0</td><td>2,2</td><td>1,3</td><td>0,8</td><td>0,5</td><td>0,6</td></tr> <tr><td>$\alpha = 45^\circ$</td><td>3,5</td><td>1,3</td><td>0,7</td><td>0,4</td><td>0,4</td><td>3,0</td></tr> </table>	$W_2 / W_1 =$	0,4	0,6	0,8	1,0	2,0	3,0	$\alpha = 60^\circ$	5,0	2,2	1,3	0,8	0,5	0,6	$\alpha = 45^\circ$	3,5	1,3	0,7	0,4	0,4	3,0	<table border="1"> <tr><td>$\zeta = 0,9$</td><td>0,6</td></tr> <tr><td>$\zeta = 1,25$</td><td>0,7</td></tr> </table>	$\zeta = 0,9$	0,6	$\zeta = 1,25$	0,7										
OR/D=0,5	0,75	1,0	1,5	2	3	4																																																									
$\zeta = 0,9$	0,43	0,33	0,24	0,19	0,17	0,15																																																									
h/b	0,25	0,5	1,5	2,0																																																											
ζ	2,1	1,7	1,2	0,6																																																											
$W_2 / W_1 =$	0,4	0,6	0,8	1,0	2,0	3,0																																																									
$\alpha = 60^\circ$	5,0	2,2	1,3	0,8	0,5	0,6																																																									
$\alpha = 45^\circ$	3,5	1,3	0,7	0,4	0,4	3,0																																																									
$\zeta = 0,9$	0,6																																																														
$\zeta = 1,25$	0,7																																																														
<table border="1"> <tr><td>R/D = 0,5</td><td>0,75</td><td>1,0</td><td>1,5</td><td>2</td></tr> <tr><td>3 Segm $\zeta = 1,3$</td><td>0,8</td><td>0,5</td><td>1,3</td><td>0,25</td></tr> <tr><td>5 Segm $\zeta = 1,1$</td><td>0,6</td><td>0,4</td><td>0,25</td><td>0,2</td></tr> </table>	R/D = 0,5	0,75	1,0	1,5	2	3 Segm $\zeta = 1,3$	0,8	0,5	1,3	0,25	5 Segm $\zeta = 1,1$	0,6	0,4	0,25	0,2	<table border="1"> <tr><td>R/W = 0</td><td>0,2</td><td>0,4</td><td>0,6</td><td>0,8</td></tr> <tr><td>$\zeta = 1,4$</td><td>0,7</td><td>0,6</td><td>0,7</td><td>1,1</td></tr> </table>	R/W = 0	0,2	0,4	0,6	0,8	$\zeta = 1,4$	0,7	0,6	0,7	1,1	<table border="1"> <tr><td>R/W = 0,5</td><td>0,75</td><td>1</td><td>1,5</td><td>2</td></tr> <tr><td>$\zeta = 1,1$</td><td>0,6</td><td>0,4</td><td>0,25</td><td>0,2</td></tr> <tr><td>$\zeta = 1,1$</td><td>0,5</td><td>0,25</td><td>0,15</td><td>0,1</td></tr> </table>	R/W = 0,5	0,75	1	1,5	2	$\zeta = 1,1$	0,6	0,4	0,25	0,2	$\zeta = 1,1$	0,5	0,25	0,15	0,1	<table border="1"> <tr><td>R/D = 0,5</td><td>0,75</td><td>1</td><td>0,5</td><td>2</td></tr> <tr><td>$\zeta = 1,3$</td><td>0,9</td><td>0,8</td><td>0,6</td><td>0,5</td></tr> </table>	R/D = 0,5	0,75	1	0,5	2	$\zeta = 1,3$	0,9	0,8	0,6	0,5	<table border="1"> <tr><td>R/D = 0,25</td><td>0,5</td><td>0,75</td><td>1,0</td></tr> <tr><td>$\zeta = 1,3$</td><td>0,1</td><td>0,05</td><td>0,05</td></tr> </table>	R/D = 0,25	0,5	0,75	1,0	$\zeta = 1,3$	0,1	0,05	0,05	
R/D = 0,5	0,75	1,0	1,5	2																																																											
3 Segm $\zeta = 1,3$	0,8	0,5	1,3	0,25																																																											
5 Segm $\zeta = 1,1$	0,6	0,4	0,25	0,2																																																											
R/W = 0	0,2	0,4	0,6	0,8																																																											
$\zeta = 1,4$	0,7	0,6	0,7	1,1																																																											
R/W = 0,5	0,75	1	1,5	2																																																											
$\zeta = 1,1$	0,6	0,4	0,25	0,2																																																											
$\zeta = 1,1$	0,5	0,25	0,15	0,1																																																											
R/D = 0,5	0,75	1	0,5	2																																																											
$\zeta = 1,3$	0,9	0,8	0,6	0,5																																																											
R/D = 0,25	0,5	0,75	1,0																																																												
$\zeta = 1,3$	0,1	0,05	0,05																																																												
<table border="1"> <tr><td>R/W = 0,5</td><td>0,75</td><td>1</td><td>2</td></tr> <tr><td>$W_1 / W = 0,25$</td><td>$\zeta = 0,4$</td><td>0,25</td><td>0,2</td><td>0,1</td></tr> <tr><td>$W_1 / W = 0,5$</td><td>$\zeta = 0,5$</td><td>0,3</td><td>0,2</td><td>0,1</td></tr> </table>	R/W = 0,5	0,75	1	2	$W_1 / W = 0,25$	$\zeta = 0,4$	0,25	0,2	0,1	$W_1 / W = 0,5$	$\zeta = 0,5$	0,3	0,2	0,1	$\zeta = 0,35$	<table border="1"> <tr><td>$\alpha = 10$</td><td>30</td><td>45</td><td>60</td><td>90</td></tr> <tr><td>$\zeta = 0,1$</td><td>0,3</td><td>0,7</td><td>1,0</td><td>1,4</td></tr> </table>	$\alpha = 10$	30	45	60	90	$\zeta = 0,1$	0,3	0,7	1,0	1,4	$\zeta = 1,4$	<table border="1"> <tr><td>$\alpha = 15$</td><td>30</td><td>45</td><td>60</td><td>90</td></tr> <tr><td>$\zeta = 0,5$</td><td>0,3</td><td>0,3</td><td>0,4</td><td>0,7</td></tr> </table>	$\alpha = 15$	30	45	60	90	$\zeta = 0,5$	0,3	0,3	0,4	0,7																									
R/W = 0,5	0,75	1	2																																																												
$W_1 / W = 0,25$	$\zeta = 0,4$	0,25	0,2	0,1																																																											
$W_1 / W = 0,5$	$\zeta = 0,5$	0,3	0,2	0,1																																																											
$\alpha = 10$	30	45	60	90																																																											
$\zeta = 0,1$	0,3	0,7	1,0	1,4																																																											
$\alpha = 15$	30	45	60	90																																																											
$\zeta = 0,5$	0,3	0,3	0,4	0,7																																																											
<table border="1"> <tr><td>$F_2 / F_1 = 0$</td><td>0,2</td><td>0,4</td><td>0,6</td><td>0,8</td><td>1,0</td></tr> <tr><td>$\zeta_2 = 0,6$</td><td>0,45</td><td>0,3</td><td>0,2</td><td>0,1</td><td>0</td></tr> </table>	$F_2 / F_1 = 0$	0,2	0,4	0,6	0,8	1,0	$\zeta_2 = 0,6$	0,45	0,3	0,2	0,1	0	<table border="1"> <tr><td>$F_2 / F_1 = 0,9$</td><td>0,8</td><td>0,7</td><td>0,6</td><td>0,5</td><td>0,4</td></tr> <tr><td>$\zeta = 0,6$</td><td>0,28</td><td>0,78</td><td>1,82</td><td>3,8</td><td>8,1</td></tr> </table>	$F_2 / F_1 = 0,9$	0,8	0,7	0,6	0,5	0,4	$\zeta = 0,6$	0,28	0,78	1,82	3,8	8,1	<table border="1"> <tr><td>$a =$</td><td>0°</td><td>30°</td><td>45°</td><td>60°</td></tr> <tr><td>$\zeta =$</td><td>1</td><td>1,5</td><td>2,5</td><td>8</td></tr> </table>	$a =$	0°	30°	45°	60°	$\zeta =$	1	1,5	2,5	8	<table border="1"> <tr><td>h/D =</td><td>0,2</td><td>0,4</td><td>0,6</td><td>0,8</td><td>1,0</td></tr> <tr><td>$\zeta =$</td><td>1,6</td><td>1,2</td><td>1,05</td><td>1,0</td></tr> </table>	h/D =	0,2	0,4	0,6	0,8	1,0	$\zeta =$	1,6	1,2	1,05	1,0	<table border="1"> <tr><td>h/D =</td><td>0,1</td><td>0,2</td><td>0,4</td><td>0,6</td><td>0,8</td><td>1,0</td></tr> <tr><td>$\zeta =$</td><td>0,7</td><td>0,4</td><td>0,7</td><td>0,8</td><td>0,8</td><td>0,8</td></tr> </table>	h/D =	0,1	0,2	0,4	0,6	0,8	1,0	$\zeta =$	0,7	0,4	0,7	0,8	0,8	0,8
$F_2 / F_1 = 0$	0,2	0,4	0,6	0,8	1,0																																																										
$\zeta_2 = 0,6$	0,45	0,3	0,2	0,1	0																																																										
$F_2 / F_1 = 0,9$	0,8	0,7	0,6	0,5	0,4																																																										
$\zeta = 0,6$	0,28	0,78	1,82	3,8	8,1																																																										
$a =$	0°	30°	45°	60°																																																											
$\zeta =$	1	1,5	2,5	8																																																											
h/D =	0,2	0,4	0,6	0,8	1,0																																																										
$\zeta =$	1,6	1,2	1,05	1,0																																																											
h/D =	0,1	0,2	0,4	0,6	0,8	1,0																																																									
$\zeta =$	0,7	0,4	0,7	0,8	0,8	0,8																																																									
$\zeta_2 = 0,1$	$\zeta = 0,1$																																																														
		<table border="1"> <tr><td>h/b =</td><td colspan="4">0,25</td><td colspan="4">0,50</td><td colspan="4">0,75...3,0</td></tr> <tr><td>R/b =</td><td>0,75</td><td>1,0</td><td>1,5</td><td>2,0</td><td>0,75</td><td>1,0</td><td>1,5</td><td>2,0</td><td>0,75</td><td>1,0</td><td>1,5</td><td>2,0...3,0</td></tr> <tr><td>$\zeta =$</td><td>0,55</td><td>0,45</td><td>0,3</td><td>0,3</td><td>0,45</td><td>0,3</td><td>0,2</td><td>0,15</td><td>0,4</td><td>0,2</td><td>0,15</td><td>0,10</td></tr> </table>	h/b =	0,25				0,50				0,75...3,0				R/b =	0,75	1,0	1,5	2,0	0,75	1,0	1,5	2,0	0,75	1,0	1,5	2,0...3,0	$\zeta =$	0,55	0,45	0,3	0,3	0,45	0,3	0,2	0,15	0,4	0,2	0,15	0,10																						
h/b =	0,25				0,50				0,75...3,0																																																						
R/b =	0,75	1,0	1,5	2,0	0,75	1,0	1,5	2,0	0,75	1,0	1,5	2,0...3,0																																																			
$\zeta =$	0,55	0,45	0,3	0,3	0,45	0,3	0,2	0,15	0,4	0,2	0,15	0,10																																																			

Table 3.1. Examples of ζ -values

Furthermore, the dependencies have already been evaluated in special diagrams and relate to a duct of 1 [m] length. Correspondingly, for rectangular ducts, the hydraulic $\varnothing d_h$ is used instead of the $\varnothing d$.

Roughness K	
Duct type	k
Plastic duct	0.005
Steel duct	0.1
Sheet metal ducts	0.15
Flexible hoses	0.7
Concrete duct	0.8

Table 3.1. Roughness coefficient k

- **Resistance coefficient.** The pressure loss in shaped components can have a variety of causes.

Resistance coefficient results from changes in direction, branches, changes in cross-section of components, as well as assemblies in heaters, coolers and filters... etc.

The calculation is performed using the formula:

eq. 3.5-07
$$\Delta p_v = \zeta \cdot \rho / 2 \cdot c^2 = \zeta \cdot p_d \quad [\text{Pa}]$$
 ζ : resistance coefficient

Mostly, the ζ -values can only be determined experimentally and are specified by the component manufacturers or handbooks.

The resistance coefficient ζ depends on the geometry and the Reynolds number of the flow, and the inlet and outlet conditions.

If several components of a system are installed immediately after one other, the ζ -values of the individual elements cannot be added together. The inlet and outlet conditions no longer correspond to the test conditions used to determine the ζ -values.

See table 3.1: – the most important ζ -values

- **Impact loss.** A resistance coefficient caused by a sudden increase in cross-section.

The deceleration of the flow from c_1 to c_2 is called impact loss. (fig. 3.7).

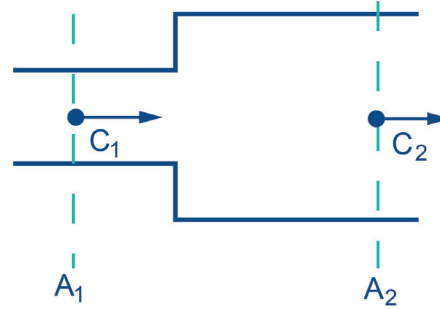

Fig. 3.7. Impact loss

the impact loss is defined by the following equation:

eq. 3.5-08
$$\Delta p_v = \zeta \cdot \rho / 2 \cdot (c_1 - c_2)^2 \quad [\text{Pa}]$$

Whereby the ζ -value lies between approx. 0,25 to approx. 0,45 for a deceleration from c_1 to c_2 from around 2 to around 3 times.

The ζ -values are higher for unequal or asymmetric widening of the cross-section.

- **Diffuser loss.** If the cross-section widens gradually, this is known as a diffuser. The diffuser has the task of decelerating the flow in a specific way, thus converting dynamic pressure into static pressure. This “pressure recovery” is significantly dependent on the opening angle, which should not be greater than $< 7^\circ$ (one side). If it is greater than $> 7^\circ$, the flow separates at the diffuser wall, which can cause large losses.

The static pressure recovery can be calculated using the formula:

eq. 3.5-09
$$\Delta p_s = (p_{d1} - p_{d2}) \cdot \eta_{\text{Diff.}} \quad [\text{Pa}]$$
 $\eta_{\text{Diff.}}$: Diffuser efficiency

Installing a diffuser behind the fan considerably reduces the power required and thus achieves a saving in investment and operating costs.

3.6 System curve (system characteristics)

Exact information on the pressure losses depending on the airflow – known as the system characteristic – is also important for the ideal configuration of the fans in the system.

The system characteristic represents the sum of all pressure losses in a system, on both the suction and the pressure sides of the fan. This total pressure difference Δp_t is assigned to a certain specified airflow V . This pair of values V and Δp_t is a simultaneous point on the system characteristic, which is also known as the resistance parabola.

The graphical representation is a quadratic parabola according to the relationship.

eq. 3.6-01
$$\Delta p_t = f(V^2)$$

- i **Note:** for some elements there could be another law, for example cubic.

3.7 Velocity distribution in the duct

The non-constant velocity distribution across the cross-section of a duct is influenced by the duct friction and the wall adhesion of the flow. Only immediately behind an inlet nozzle is the velocity (nearly) evenly distributed.

The velocity profile is fully developed after a distance of around $10 \cdot d$ (fig. 3.8).

When determining the airflow, ensure that the profile formation is taken into account when taking measurements for the average flow velocities.

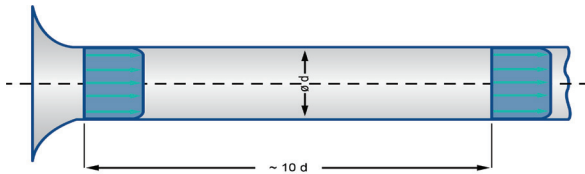

Fig. 3.8. Flow profile (duct with nozzle)

Flow separation, takes place behind bends and elbow joints on the inner side, with irregular velocity profiles (fig 3.9-3.11).

Here the static pressure on the outside is larger than that on the inside – where it is even possible for an underpressure to form.

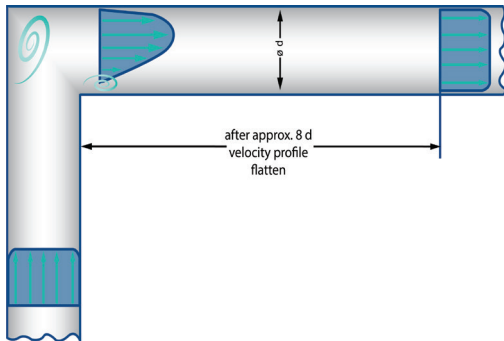

Fig. 3.9. Flow profile (elbow joint)

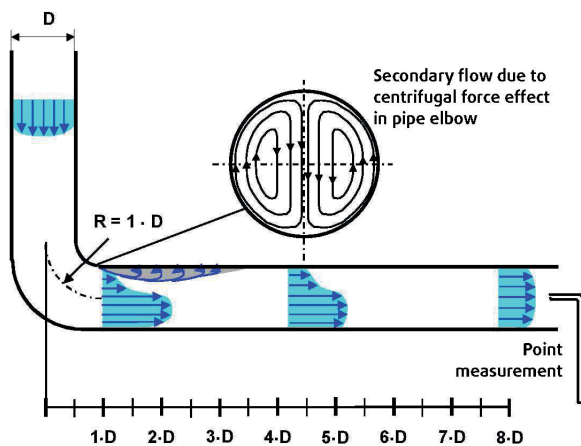

Fig. 3.10. Flow profile (duct bend)

It can be seen from the following flow images of a duct bend, that no fans should be installed directly behind these components.

The blue flow fields represent the separation of flow, which massively disrupts the gas being transported by the fan and, furthermore, significantly and uncontrollable influence on mechanical load of the impeller.

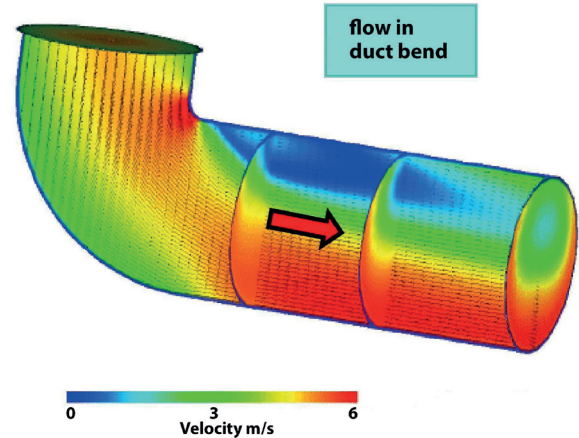

Fig. 3.11. Flow diagram – bend in duct

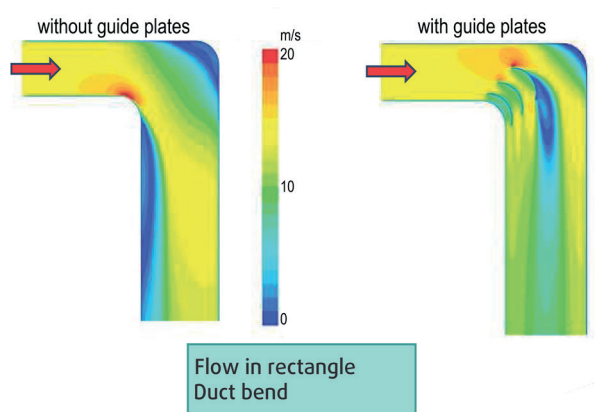

Fig. 3.12. Flow diagram – bend in duct with / without guide plate

Fig 3.12 shows that although the guide plate influences the flow positively, it cannot eliminate the turbulence.

3.8 Pressure measurements in situ

Fig. 3.13 shows the basic planes for site measuring the three pressures – p_s , p_d and p_t

- p_s – static pressure (p. 3.4.1).

This can be measured using differential manometer connected via a tube to a wall pressure tapping (fig. 3.14) in the duct, or to a pitot tube / pitot-static tube. The bore diameter of the tapping should be 1,5-5 [mm] (but not greater than 10% of the duct diameter). It is essential that these holes are produced carefully so that the bore is normal to and flush with the inside surface (internal protrusions should be removed).

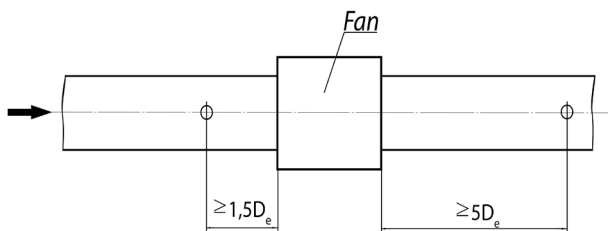

Fig. 3.13. Location of pressure measurement planes for site testing (ISO 5802)

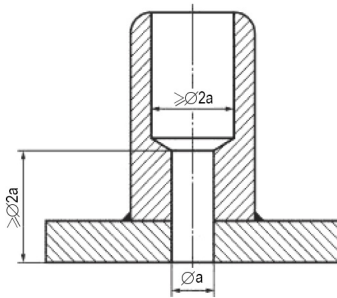

Fig. 3.14. Construction of wall pressure tapplings (ISO 5802)

- p_d – dynamic pressure (p. 3.4.2).

This can be measured using a differential manometer connected via a tube to a pitot tube.

- p_t – total pressure (p. 3.4.3).

This can be measured using a differential manometer connected via a tube to a total pressure tube/pitot tube or calculated as a sum of the static and dynamic pressure.

In real ventilation systems usually, people cannot meet such installation conditions and do not have $5D_e$ on the outlet or/and $1,5D_e$ on the inlet of the fan. In such cases, pressures can be measured closer to the fan, but the velocity distribution in the measuring planes should be checked.

It is very important because in some cases the distribution of the velocities could be not appropriate for measurements, for example, separation of flow and backward flows (see ISO 5802)

For more information, see p.6.9.

4. Acoustics

4.1 Noise

Noise is determined as sound which causes harm to the health and is estimated negatively. The harming influence on the human organism is very different. Long influence of an intensive noise (over 80 dBA) on the human's ear can cause partial or full loss of hearing. Influence of the noise is not limited only to the loss of hearing through the

hearing nerves noise influences on the human's nervous system and then even on human's internal organs. For impulse and nonregular noises, the influence is even more. For this reason, acoustics appear – to measure the levels of noise and to defend people's health.

4.2 Basic principles of sound

To determine the levels of noise people introduced several physical quantities, the main are – sound pressure, sound power and frequency.

Sound pressure

Sound pressure is the pressure waves with which the sound moves in a medium, for instance, air. The ear interprets these pressure waves as sound. They are measured in Pascal [Pa].

The weakest sound pressure that the ear can interpret is 0,00002 Pa (p_0), which is the threshold of hearing. The strongest sound pressure which the ear can tolerate without damage is 20 [Pa], referred to as the upper threshold of hearing.

The large difference in pressure, as measured in [Pa], between the threshold of hearing and the upper threshold of hearing, makes the figures difficult to handle. So a logarithmic scale is used instead, which is based on the difference between the actual sound pressure level (p) and the sound pressure at the threshold of hearing. This scale uses the decibel (dB) unit of measurement, where the threshold of hearing is equal to 0 [dB] and the upper threshold of hearing is 120 [dB].

To recalculate [dB] from [Pa] you can use the following formula:

$$\text{eq. 4.2-01} \quad L = 20 \cdot \lg(p/p_0) \quad [\text{dB}]$$

The sound pressure reduces as the distance from the sound source increases and is affected by the room's characteristics and the location of the sound source. Sound pressure can be measured by the microphone.

Sound power

Sound power is the energy per time unit (Watt) which the sound source emits. The sound power is not measured, but it is calculated from the sound pressure. There is a logarithmic scale for sound power similar to the scale for sound pressure.

The sound power is not dependent on the position of the sound source or the room's sound properties, and it is, therefore, easier to compare between different objects.

Sound power is not measured directly, it is calculated from the sound pressure.

Frequency

Frequency (f) is a measurement of the sound source's periodic oscillations. Frequency is measured as the number of oscillations per second, where one oscillation per second equals 1 Hertz (Hz). More oscillations per second, i.e. a higher frequency, produces a higher tone.

In the range 16 [Hz]-20000 [Hz] these oscillations are called sound. Lower than 16 [Hz] they are called infrasound and higher than 20000 [Hz] ultrasound.

Frequencies are often divided into 8 groups, known as octave bands: 63 [Hz], 125 [Hz], 250 [Hz], 500 [Hz], 1000 [Hz], 2000 [Hz], 4000 [Hz] and 8000 [Hz].

Knowing frequency you can calculate the length of the sound wave:

$$\text{eq. 4.2-02} \quad \lambda = c/f, \quad [\text{m}]$$

c: is the speed of the sound, [m/s].

Direction diagram

Usually, sound sources are not emitting sound in all directions in the same way. You can compare the sound source with the lantern. Lantern power is the analogue to the sound power of the sound source and illumination is the analogue to the intensity of the sound. Illumination is decreasing in the same way as the intensity of the sound when the distance to the source increases. The lantern is shining not equally in all the directions and in the same way the sound source does. This is called direction diagram and that is why it is usually necessary to measure sound pressure in several points and using this measurement calculate sound power:

$$\text{eq. 4.2-03} \quad W = \int \frac{\bar{p}^2}{\rho c} ds, \quad [\text{W}]$$

$$\text{eq. 4.2-04} \quad L_w = 10 \cdot \lg(W/W_0), \quad [\text{dB}]$$

where $W_0 = 10^{-12}$ [W]

4.3 Sources of sound

Sources of sound can be very different. But the main types are mechanical sounds, aerohydrodynamic sounds and electrical sounds.

Mechanical sounds are usually presented in the production plants or in the places where there are a lot of machines. The main sources of these sounds are gearboxes, cam mechanisms, chain drives, gears, bearings, forging equipment, etc.

The electrical sound can be attributed to the magnetic sound of electric motors, the sound of electrical components of the control system, etc.

Aerodynamic sound is usually divided into broadband sound and discrete sound. Broadband sound is connected to the turbulence near the solid boundaries (vortex sound, boundary layer sound) and separation of flow. Discrete sound is connected to the heterogeneity of the flow and interaction of the various elements in the flow path.

Discrete sound has usually greater input into the sound power (fig. 4.1). When we are talking about the fan, its discrete sound frequencies are connected with the speed of rotation (n) and the number of blades (z). For example, there can be sound close to the $f=n/60$ (depending on the number of zones of flow separation) and it can be connected with the rotating stall or bad balancing of the wheel, or on frequencies $f=mzn/60$ (where m is an integer number) and then it is connected with the number of blades. If you have guide vanes there could be discrete sounds connected with a combination of wheel and vane blade number.

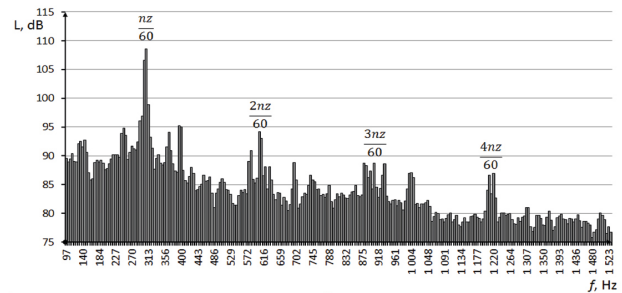

Fig. 4.1. Narrowband spectrum of the fan sound ($n=1470$ rpm, $z=12$)

4.4 Adjustment to the ear

Because of the ear's varying sensitivity at different frequencies, the same sound level in both low and high frequencies can be perceived as two different sound levels. As a rule, we perceive sounds at higher frequencies more easily than at lower frequencies.

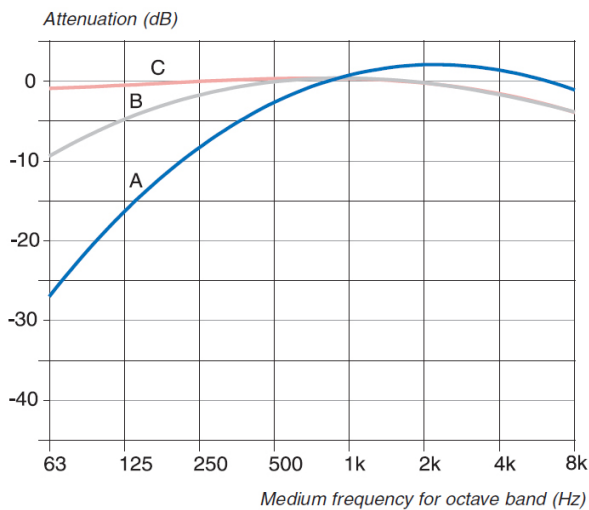

Fig. 4.2. Damping with different filters

A filter

The sensitivity of the ear also varies in response to the sound's strength. Several so-called weighting filters have been introduced to compensate for the ear's variable sensitivity across the octave band. A weighting filter A is used for sound pressure levels below 55 [dB]. Filter B is used for levels between 55 and 85 [dB], and filter C is used for levels above 85 [dB] (fig. 4.2).

The A filter, which is commonly used in connection with ventilation systems, has a damping effect on each octave band as shown in table 4.1. The resultant value is measured in [dB(A)] units.

[Hz]	63	125	250	500	1k	2k	4k	8k
[dB]	-26.2	-16.1	-8.6	-3.2	0	+1.2	+1	-1.1

Table 4.1. Damping with the A filter

There are other ways of compensating for the ear's sensitivity to different sound levels, apart from these filters. A diagram with NR curves (Noise Rating) shows sound pressure and frequency (per octave band). Points on the same NR curve are perceived as having the same sound levels, meaning that 43 [dB] at 4000 [Hz] is perceived as being as loud as 65 [dB] at 125 [Hz].

4.5 Several sound sources

To establish the total sound level in a room, all the sound sources must be added together logarithmically. It is, however, often more practical to use a diagram to calculate the addition or subtraction of two [dB] values.

Addition (fig. 4.3)

The input value for the diagram is the difference in [dB] between the two sound levels are to be added. The dB value to be added to the highest sound level can then be read off the y scale.

Subtraction (fig. 4.4)

The input value for the diagram is the difference in [dB] between the total sound level and the known sound source. The y scale then shows the number of dB that have to be deducted from the total sound level to get the value for the unknown sound source.

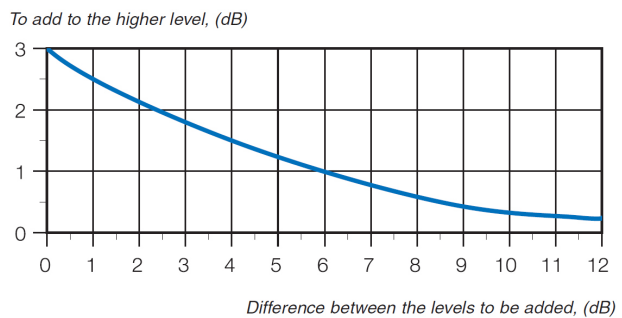

Fig. 4.3. Logarithmic addition

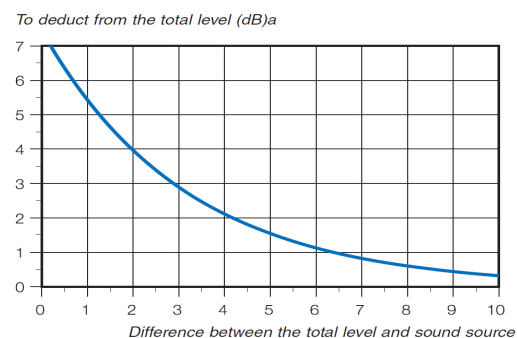

Fig. 4.4. Logarithmic subtraction

4.6 Acoustical similarity laws for fans

Aerodynamic noises dominate in the fan's noise. From the point of view of the theory of similarity of aerodynamic noise sources in fans, the total sound power W is proportional to the circumferential speed $u_2 = (\pi D_2 n) / 60$ on the outer diameter D_2 of the fan impeller:

$$W = k \cdot u_2^5 \cdot D_2^2$$

k is a factor which usually depends on Reynolds number, geometry and the parameters of the flow. Going to the logarithmic scale we will get the following formula:

eq. 4.6-01

$$L_w = L_z + 50 \cdot \lg(u_2) + 20 \cdot \lg(D_2)$$

Where L_z total abstract sound power level. This formula allows you to convert the sound power level of the selected fan type from one speed of rotation to another and from one size to another.

If under the theory of similarity, the formula for sound power is converted in terms of the total pressure P_v , air-flow V and the corresponding dimensionless coefficients, then we get an expression for sound power:

$$W = k_1 \cdot V \cdot P_v^2$$

k_1 is a factor which usually depends on the fan type and the conditions of work. Going to the logarithmic scale we will get the following formula:

eq. 4.6-02

$$L_w = L_{1z} + 10 \cdot \lg(V) + 20 \cdot \lg(P_v)$$

Where L_{1z} is the total noise criterion of the fan of a particular type. This formula can recalculate the acoustic of the selected fan in terms of the airflow and total pressure at similar working points.

Example:

When we have sound power (100 [dB]) at the nominal operating conditions for the fan with a diameter of the impeller $D_2 = 0,4$ [m] and velocity of rotation $n = 2880$ [min^{-1}] and we want to know the sound power at the nominal operating conditions for the geometrically similar fan with $D_2 = 0,63$ [m] and velocity of rotation $n = 1400$ [min^{-1}], we should first calculate abstract sound power level:

$$L_z = 100 - 50 \cdot \lg(60,3) - 20 \cdot \lg(0,4) = 18,9 \text{ [dB]}$$

Then the sound power of a similar fan will be:

$$L_w = 18,9 + 50 \cdot \lg(46,2) + 20 \cdot \lg(0,63) = 98,1 \text{ [dB]}$$

4.7 Silencers

Sound silencers are usually divided into two big groups: active and reactive silencers.

In the active types (fig. 4.5) the energy is absorbed by some kind of porous material and transformed into the heat. Usually, the pressure losses in such silencers are rather low, because the flow is usually going along the surface of absorption. But the speed of the air shouldn't be greater than 7-8 [m/s], otherwise, you can achieve additional sound generation by a silencer.

Effectiveness of a silencer is connected with the thickness of the absorbing material, with the length of silencer, with the translucency of the silencer walls (it should be about 25-30 [%]) and with absorbing material.

For example, for effective sound absorption on frequencies 500-600 [Hz], it is enough to have a material with thickness 50mm (fig. 4.6). For the low frequencies, needed thicknesses are too big and reactive silencers are used.

The length of a silencer is usually calculated in "calibres". When you have a silencer with a round cross-section with the $D=200$ [mm] and the length $L=600$ [mm], you have $600/200$ – three calibres. Usually, silencers with 3-5 calibres are used and for 8-10 calibres the additional absorption becomes too low. When the cross-section is too big, and the length is too small, the absorption can be increased by the use of additional absorbing plates which divide silencer on several with lower cross-section and therefore greater length in calibres.

Reactive type sound silencers, as it was said above are mainly designed to reduce sound at low frequencies or well-expressed sound at discrete frequencies. They can be a chamber, resonance, etc., and are in one form or another resonant volume or related volumes. For example, in a chamber silencer (some closed volume with input and output holes, fig. 4.7), the effect of sound reduction at low frequencies at $B_x < \lambda/4$ (B_x is the largest characteristic

cavity size, λ is the characteristic length of the acting sound wave) is associated with the expansion of the sound wave at the entrance to the camera. The sound transmission through the chamber the less, the larger the chamber size and higher frequency. The reduction of the sound passing through the camera depends very much on the frequency, so the geometrical dimensions of the camera are chosen in a special way to get the maximum sound suppression at the most important frequencies set in advance. Thus, sound at predetermined frequencies can be reduced in chamber silencer more than on 25 [dB].



Fig. 4.5. View of the active silencer

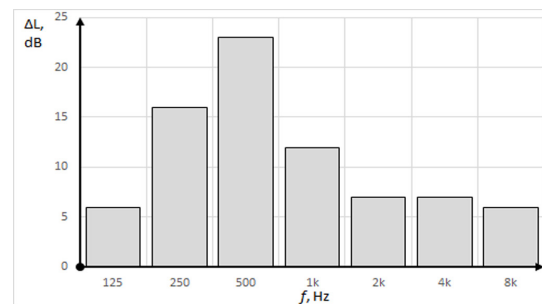

Fig. 4.6. Example of sound absorption for active silencer.



Fig. 4.7. Example of reactive silencer

4.8 Sound in the airways

On the distribution of noise in airways influence different fittings, various local resistance, distributing and receiving lattices, etc. It is necessary to remember that for the aerodynamic noise source in the duct system, such as flexible air ducts and lattices (sources of turbulence), tees, elbows, bends, dampers (sources of flow separation), the radiated sound power is proportional to the aerodynamic power losses. Therefore, to exclude the possibility of additional noise generation by the flow in the air duct system, the air velocity through the airways and in the shaped elements should be lower than 6-8 [m/s]. For example, a silencer with perforated walls and with a sound-absorbing material at an air velocity of over 10-12 [m/s] can be a source of additional noise at frequencies above 1-2 [kHz].

All kinds of fittings, dampers, grilles, etc. are some acoustic heterogeneity and with the proper design of the ventilation system can reduce the sound power distribution through the system. Some firms that produce air ducts and elements of ventilation systems, provide data on the reduction of sound power in these elements, which can be used in acoustic calculations. If such data are not available, you can use the recommendations which are given below.

In strait airways (or with insignificant curvature) of constant cross-section, there is some decrease in sound power which is given in the table. 4.2 per 1 [m] of length.

Cross-section	Hydraulic diameter, [mm]	[Hz]			
		125	250	500	1000 and higher
Round	75 – 200	0,1	0,15	0,15	0,3
	200 – 400	0,1	0,1	0,15	0,2
	400 – 800	0,06	0,06	0,1	0,15
	800 – 1600	0,03	0,03	0,06	0,06
Rectangular	75 – 200	0,6	0,45	0,3	0,3
	200 – 400	0,6	0,45	0,3	0,2
	400 – 800	0,6	0,3	0,15	0,15
	800 – 1600	0,3	0,15	0,1	0,06

Table 4.2. Decrease of sound power for 1m length in strait airways, [dB/m]

The open end of the airway partially reflects sound waves distributing through the airway back into the airway. The reflection depends on the ratio of the wavelength and diameter of the airway t , flange geometry, but for evaluation in the first approximation, you can use the table. 4.3.

Smooth straight turns also reduce sound power. In this case, straight turn without rounding gives a greater reduction than the turn with smooth rounding. In table. 4.4, 4.5 given the data reduction of sound power at a 90-degree turn without sound-absorbent in it.

Hydraulic diameter, [mm]	[Hz]						
	250	500	1k	2k	4k	8k	
25	22	19	15	10	6	2	0
50	19	15	10	5	2	0	0
80	16	11	7	3	0	0	0
100	14	10	5	2	0	0	0
125	13	8	4	1	0	0	0
140	12	8	4	1	0	0	0
160	11	7	3	0	0	0	0
180	11	6	2	0	0	0	0
200	10	6	2	0	0	0	0
225	9	5	1	0	0	0	0
250	8	4	1	0	0	0	0
280	8	3	1	0	0	0	0
315	7	3	0	0	0	0	0
350	6	2	0	0	0	0	0
400	5	2	0	0	0	0	0
450	5	1	0	0	0	0	0
500	4	1	0	0	0	0	0
560	3	1	0	0	0	0	0
630	3	1	0	0	0	0	0
710	2	0	0	0	0	0	0
800	2	0	0	0	0	0	0
1000	1	0	0	0	0	0	0
1250	0	0	0	0	0	0	0

Table 4.3. Decrease of sound power going out from the airway because of the reflection, [dB]

Width of the channel in the turn plane, [mm]	[Hz]						
	125	250	500	1k	2k	4k	8k
125-250	0	0	0	1	2	3	3
250-500	0	0	1	2	3	3	3
500-1000	0	1	2	3	3	3	3
1000-2000	1	2	3	3	3	3	3

Table 4.4. Decrease of sound power in straight turn, [dB]

Width of the channel in the turn plane, [mm]	[Hz]						
	125	250	500	1k	2k	4k	8k
125	0	0	1	5	7	5	3
250	0	1	5	7	5	3	3
500	1	5	7	5	3	3	3
1000	5	7	5	3	3	3	3
2000	7	5	3	3	3	3	3

Table 4.5 Decrease of sound power in the turn with rounding, [dB]

Performing calculations with the use of the above data, it should be remembered that the distribution of air flow and sound through rectangular airways may cause resonant excitation of some walls of the duct with unpredictable increases in sound levels distributing inside and outside the duct. If this is the case, it is necessary to act locally on the exciting wall of the air duct, for example, to stick a vibration-absorbing material on it.

In addition, we should keep in mind that even small leaks in the ventilation system, especially near the fan, can cause not only air leaks and pressure losses but also more serious sound problems. First, even a small hole in the duct transmits sound from the inside to the outside well and can negate all efforts to soundproof the airways. Secondly, the air flowing through such holes under the influence of pressure drop on the duct wall can generate sometimes very intense whistling sound. Therefore, when creating low-noise ventilation systems, it is important to control the tightness of all their sections.

4.9 Sound power level and sound pressure level in situ

There is a link between a sound source's sound power level and the sound pressure level. If a sound source emits a certain sound power level, the following factors will affect the sound pressure level: The position of the sound source in the room, including the direction factor (1), the distance from the sound source (2) and the room's sound-absorbing properties, referred to as the room's equivalent absorption area (3).

Direction factor, Q

The direction factor shows the sound's distribution around the sound source. Distribution in all directions, spherical, is measured as $Q = 1$. Distribution from a diffuser positioned in the middle of a wall is hemispherical, measured as $Q = 2$.

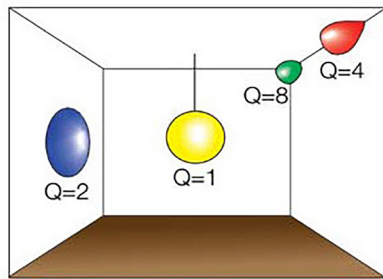

Fig. 4.8. The distribution of sound around the sound source.

- $Q = 1$ In centre of room
- $Q = 2$ On wall or ceiling
- $Q = 4$ Between wall or ceiling
- $Q = 8$ In a corner

Distance from sound source, r

Where r indicates the distance from the sound source in metres.

The room's equivalent absorption area, A_{eqv}

A material's ability to absorb sound is indicated as an absorption factor α . The absorption factor can have a value between '0' and '1', where the value '1' corresponds to a fully absorbent surface and the value '0' to a fully reflective surface. The absorption factor depends on the qualities of the material, and tables are available which indicate the value for different materials.

A room's equivalent absorption area is measured in $[\text{m}^2]$ and is obtained by adding together all the different surfaces of the room multiplied by their respective absorption factors.

In many instances it can be simpler to use the mean value for sound absorption in different types of rooms, together with an estimate of the equivalent absorption area (see fig. 4.8).

Equivalent absorption area based on estimates

If values are not available for the absorption factors of all the surfaces, and a more approximate value of the room's total absorption factor is quite adequate, an estimate can be calculated in accordance with the diagram below. The diagram is valid for rooms with normal proportions, for example 1:1 or 5:2.

Use the diagram as follows to estimate the equivalent absorption area: calculate the room's volume and read off the equivalent absorption area with the correct mean absorption factor, determined by the type of room, see also fig. 4.9.

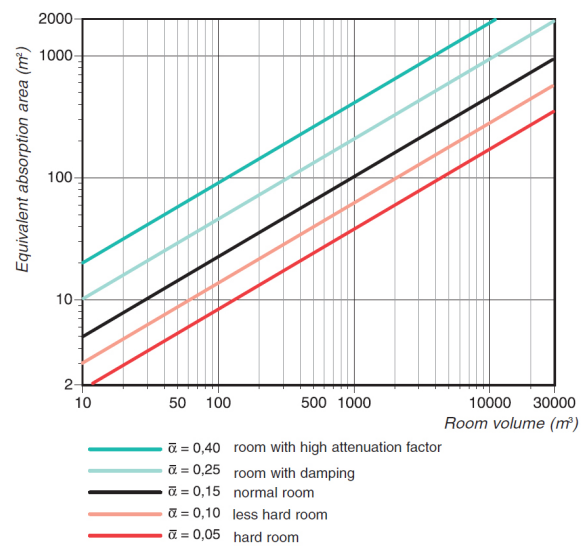

Fig. 4.9. Estimate of equivalent absorption area.

Calculation of sound pressure level

eq. 4.9-01

$$L_{\text{pA}} = L_{\text{WA}} + 10 \cdot \lg \left[\frac{Q}{4\pi r^2} + \frac{4}{A_{\text{eqv}}} \right]$$

where

L_{pA} = sound pressure level [dB]

L_{WA} = sound power level [dB]

Q = direction factor

r = distance from sound source [m]

A_{eqv} = equivalent absorption area [m^2 Sabine]

Calculation of reverberation time

If a room is not too damped (i.e. with a mean absorption factor of less than 0,25), the room's reverberation time can be calculated with the help of Sabine's formula:

eq. 4.9-02

$$T = 0,163 \cdot \frac{V}{A_{\text{eqv}}}$$

where

T = Reverberation time [s]. Time for a 60 [dB] reduction of the sound pressure value

V = Room volume [m^3]

A_{eqv} = The room's equivalent absorption area, [m^2]

Calculation of sound pressure level

With the help of the factors previously described, it is now possible to calculate the sound pressure level if the sound power level is known. The sound pressure level can be calculated by a formula incorporating these factors, but this equation can also be reproduced in the form of a diagram.

When the diagram is used for calculating the sound pressure level (fig. 4.10), you must start with the distance in metres from the sound source (r), apply the appropriate

Type of room	Mean absorption factor
Radio studios, music rooms	0,30 - 0,45
TV studios, department stores, reading rooms	0,15 - 0,25
Domestic housing, offices, hotel rooms, conference rooms, theatres	0,10 - 0,15
School halls, nursing homes, small churches	0,05 - 0,10
Industrial premises, swimming pools, large churches	0,03 - 0,05

Table 4.6. Mean absorption factors for different types of rooms

Calculation of equivalent absorption area A_{eqv} where

eq. 4.9-03

$$A_{eqv} = \alpha_1 \cdot S_1 + \alpha_2 \cdot S_2 + \dots + \alpha_n \cdot S_n$$

S = Size of surface [m^2]

α = Absorption factor, depending on the material

n = Number of surfaces

Calculation of sound pressure level. Estimate based on fig. 4.9, fig. 4.10 and fig. 4.11 together with table 4.6.

A normally damped room in a nursing home, measuring 30 [m^3], is to be ventilated. According to the information in the catalogue, the directional supply air terminal device fitted in the ceiling has a sound pressure level (L_{pA}) of 33 [dB(A)].

This applies to a room with a space damping equivalent to 10 [m^2 Sabine] 4 [dB].

A) What will the sound pressure level be in this room, 1 [m] from the diffuser?

The sound pressure level depends on the room's acoustic properties, so, first it is necessary to convert the value in the catalogue to a sound power level (L_{WA}).

$$\text{According to the space damping } \Delta L = L_{pA} - L_{WA}$$

$$L_{WA} = L_{pA} + \Delta L$$

$$L_{WA} = 33 + 4 = 37 \text{ [dB(A)]}$$

With the following values

$$r = 1 \text{ [m]}$$

$$Q = 2 \text{ (fig. 4.8)}$$

And information about the room's dimensions, you can calculate the equivalent absorption area with the help of fig. 4.12.

$$L_{pA} - L_{WA} = 0$$

$$L_{pA} = 0 + L_{WA}$$

Enter the L_{WA} value which has already been calculated.

$$L_{pA} = 0 + 37 = 37 \text{ [dB(A)]}$$

A) The sound pressure level (L_{pA}) one metre from the diffuser in this particular nursing home room is therefore 37 [dB(A)].

directional factor (Q), and then read off the difference between the sound power level and the sound pressure level next to the relevant equivalent absorption area (A_{eqv}). This result is then added to the previously calculated sound power.

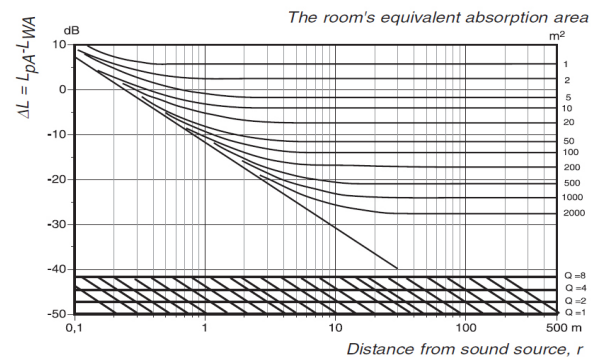

Fig. 4.10. Diagram for estimating the sound pressure level

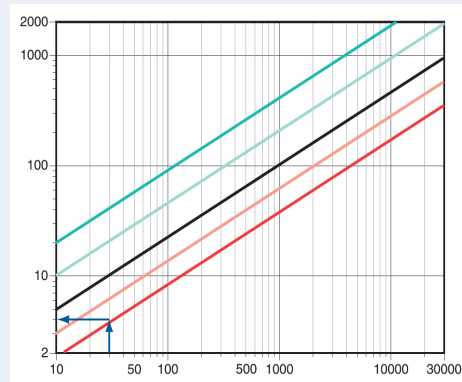

Fig. 4.11.

According to the fig. 4.11 the equivalent absorption area is 4 [m^2].

It is now possible to use fig. 4.12 to establish the difference between sound pressure and sound power.

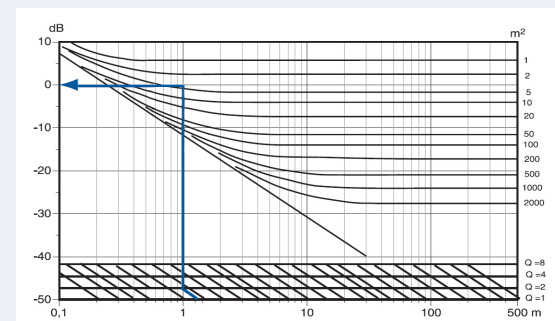

Fig. 4.12.

This calculation has to be made for all rooms not corresponding to the information in the catalogue which assumes a standard 10 [m^2 Sabine].

The less damped (harder) the room is, the higher the actual sound pressure level will be in comparison with the value stated in the catalogue.

5. Basic of fans

5.1 What is a fan?

What is a fan?

A fan is a fluidic machine which transports a gaseous medium air through a system, mixes air in some place or creates a jet of air. The system functions as a brake due to its resistance (total pressure of the system), which the fan must overcome. The fan can be seen as the heart of a system.

Fans are used to overcome resistances when transporting gases (air) in ventilation and air-conditioning equipment as well as in process equipment. The type of application is determined by the type of construction of these machines.

5.2 Types of fans

The type designation is derived from how the air flows through the impeller. In general, there are three different types of fans:

- axial
- radial
- crossflow

- **Axial construction** (fig. 5.1). The gas flows straight through the fan along the axis of rotation.

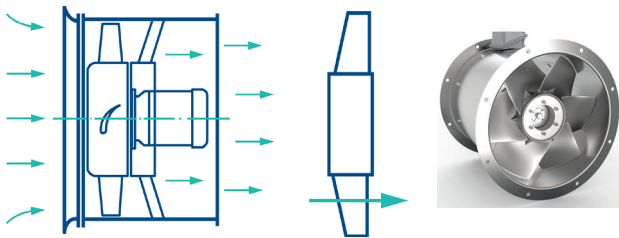

Fig. 5.1. Axial fan

Sometimes axial fans are used with inlet or/and outlet guide vanes. Inlet guide vanes can be used for regulation purposes. Guide vanes can increase efficiency, pressure and reduce the swirl on the outlet of the fan.

Axial fans are usually used for high airflows and not so high pressure.

To increase the pressure two axial fans in series or counter-rotating fan can be used.

- **Radial construction** (centrifugal (fig. 5.2)). The gas is sucked in an axial direction and leaves the impeller at right angles to the axis of rotation (in a radial direction).

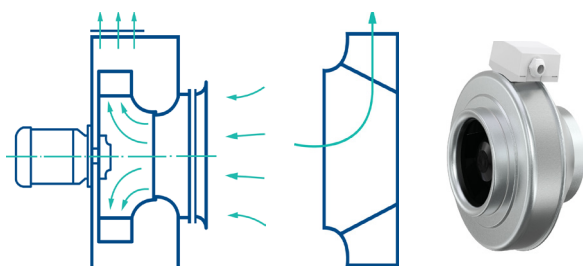

Fig. 5.2. Radial fan

This type of construction is usually divided into three different radial impellers:

- Impeller with backwards curved blades
- Impeller with forwarding curved blades
- Radially ending impeller blades

Also, the impeller can have a sheet or profiled blades. Radial fans are usually used when high pressure is needed.

Radial fans can be used with different casings, for example, scroll casing, inline casing or without casing.

- **Mixed-flow construction** (fig. 5.3). This type of construction lies somewhere between the axial and radial types. The gas flows in a curve through the impeller.

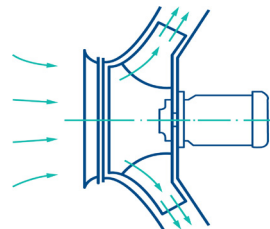

Fig. 5.3. Mixed-flow fan

- **Crossflow fans** (fig. 5.4)

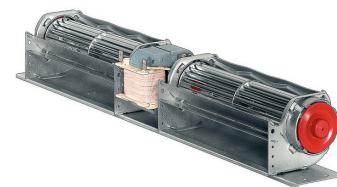

Fig. 5.4. Crossflow fan

Crossflow fans have an impeller which looks like radial impeller with forwarding curved blades, but it works in a totally different way. The flow comes into the impeller in a radial direction, at the right angles to the axis of rotation, goes through the impeller and goes out on the other side (air goes along the diameter of the impeller). The design of the casing is very important in this type of fan.

Crossflow fans are widely used in split systems, air curtains and some special purpose systems. There are of course some other types of fans, for example, vortex fan but they are not so widely used.

5.3. Axial fan

5.3.1 Construction and function

The simplest axial fan usually consists of the components presented on fig. 5.5.

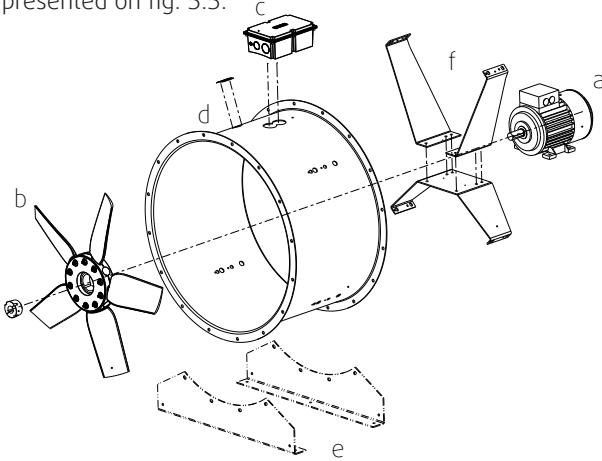

- a. Motor
- b. Impeller
- c. Terminal box
- d. Housing
- e. Mounting feet
- f. Motor brackets

Fig. 5.5. Components I



Fig. 5.6. Diffuser

For other requirements, the following additional components can be used::

- Inlet nozzle
- Outlet diffuser (fig. 5.6)
- Outlet guide vanes (fig. 5.7)
- Inlet guide vanes
- Antistall devices (fig. 5.8)
- And other (fig. 5.9)

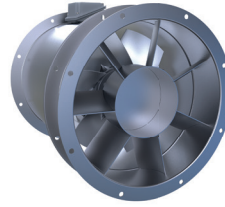

Fig. 5.7. Outlet guide vanes

Inlet nozzles create a uniform velocity distribution in front of the impeller. Inlet guide vanes are positioned in front of the impeller and can produce a swirl toward impeller rotation or in the opposite way. This allows to regulate fans characteristics.

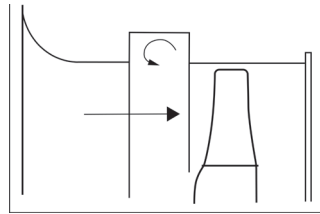
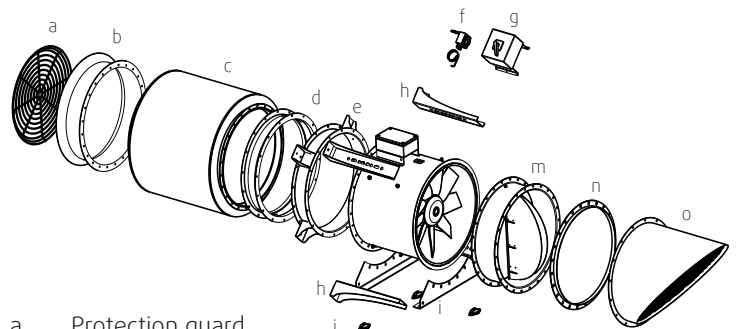

Fig. 5.8. Antistall ring



- a. Protection guard
- b. Inlet cone
- c. Silencer
- d. Flexible connection
- e. Mounting ring
- f. Isolator switch
- g. Isolator switch
- h. Mounting bracket
- i. Mounting foot
- j. Rubber anti-vibration mounts
- k. Spring anti-vibration mounts
- l. Suspension spring anti-vibration mounts
- m. Air operated damper
- n. Counter flange
- o. Outlet cowl

Fig. 5.9. Components II

Whereas outlet guide vanes are located behind the impellers and reorientate the swirling flow, giving it an axial direction (fig 5.10). Diffusers – mounted on the pressure side

of the fan – convert the high dynamic pressure into static pressure to save energy, thus considerably improving the cost-effectiveness.

Blade angle reduction results in a drop in the total pressure and therefore of the airflow without far-reaching changes to the efficiency across broad control ranges. It is possible to control the airflow from 0 to 100 [%] by adjusting the blade angle or by changing the impeller blades. Maintaining constant airflow with changing pressure is also not a problem. Vane controllers are air inlet components with infinitely adjustable blades controlled by a servomotor. The advantage of a vane controller is the use of the kinetic energy directly in front of the impeller. The cost-effective application of a vane controller lies between around 60 [%] and 100 [%] of the rated volume at a constant speed.

Axial fans and radial fans with backward curved blades are suitable for use with a vane controller. But in contrary from radial fans, usage of inlet guide vanes with axial fans can highly increase fans pressure.

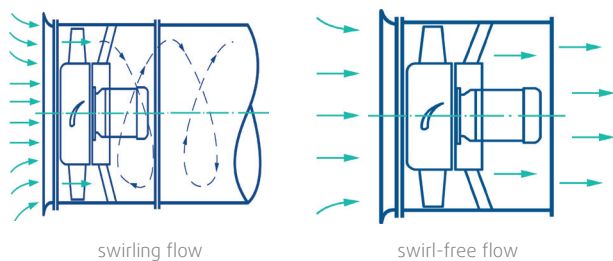

Fig. 5.10. Outlet guide vanes

The airflow direction in the axial fan can be from impeller to motor direction (D) or suction across the motor (S) (fig. 5.11).

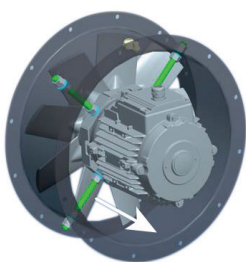

Fig. 5.11. Diagram showing air-flow direction D

Usually, two types of impellers are used: with cast hub or with a welded hub.

A. Molded impeller hub and blades (fig. 5.12).

Pluses:

- Adjustable blade angle
- Easy to assembly
- Can be used for temperatures up to 400 [°C]

Minuses:

- Fixed number of blades
- Fixed hub diameter
- Rather big gap between blade and hub
- Harder to use with guide vanes

B. Impeller with rigidly welded-on blades (fig. 5.13).



Fig. 5.12. Axial impeller, diagram showing different arrangements of blades on hub



Fig. 5.13. Steel impeller

Pluses

- The interlocking arc profile is ideally adjusted to the inlet/outlet guide vanes
- Can be used for temperatures up to 600 [°C]
- No gap between blade and hub
- Any number of blades
- Any size of hub

Minuses:

- Not adjustable blade angle
- Hard to assembly
- Harder to balance

5.3.2 Types of axial fans

Depending on the application and operating conditions, axial fans can be classified according to their different aspects:

- Axial fans with a different guide vane arrangement
 - without guide vanes
 - with inlet guide vanes
 - with an outlet and inlet guide vanes
 - with outlet guide vanes
- Axial fans with different hub ratio (table 5.1). The hub ratio is the ratio of the hub diameter to the impeller outer diameter.

Axial fan type	Hub ratio	Pressure coefficient (see point 6.4)
Low pressure fan	<0,4	<0,25
Medium pressure fan	0,4-0,6	0,25-0,55
High pressure fan	>0,6 and conic	0,55-1,2

Table 5.1

Axial fans for different purposes:

General-purpose fans. Standard fans for gas temperatures up to 55 [°C]

Jet fans (fig. 5.14)

Counterrotating fans

Reversible fans

Fireproof fans (table 5.2)

- **Hot gas fans.** Up to around 300 [°C] in continuous operation possible. Special designs can achieve even higher temperatures. Area of application: Process air technology, thermal processes
- **Smoke / combustion gas extractor fans.** Fans requiring accreditation and safety-relevant fans suitable for certain temperatures/time classes according to the Inspection Standard EN DIN 12101-3

ID	Temp. class	Time class
F200	200 [°C]	120 [min]
F300	300 [°C]	60 [min]
F400	400 [°C]	120 [min]
F600	600 [°C]	60 [min]
F842	842 [°C]	30 [min]

Table 5.2

Explosion-proof fans

Multistage fans (fig. 5.14), etc.

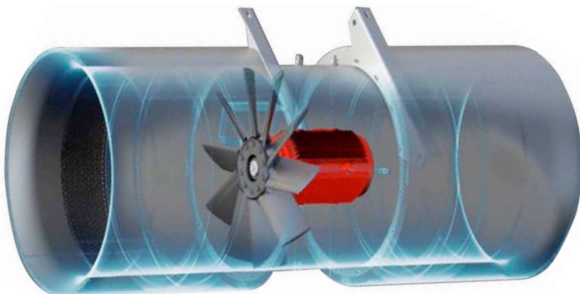

Fig. 5.14. Tunnel JET fan

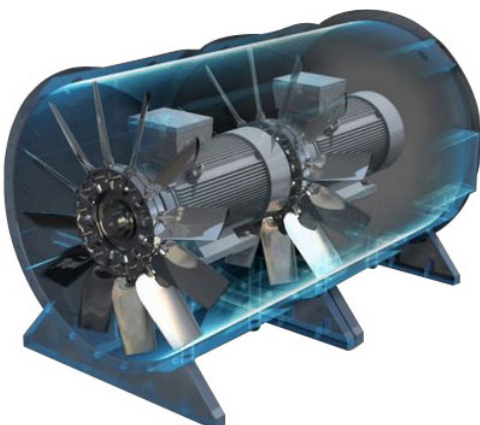

Fig. 5.15. Two-stage tunnel fan

- **Axial fans with speed control.** Electric motors controlled via frequency converters are ideal for combination with fans. Good location of the operating points in the system characteristic field, for direct drive and belt drive, excellent behaviour in the partial load range, favourable

acoustics and a simple design guarantee trouble-free operation. However, vibrational phenomena should be checked ahead of commissioning and dealt with accordingly.



Fig. 5.16. Reversible axial fan

- **Types of drive.** The type of drive is essentially determined by the application conditions and the corresponding requirements.

In accordance with VDMA 24164, there are essentially four types of drive for axial fans:

M: Direct drive by motor shaft (fig.5.16, 5.17)

The impeller sits on the motor stub shaft, the most common type of drive-in fan construction Low space requirement and low maintenance costs



Fig. 5.17. Low pressure-axial fan

A: Direct drive by external rotor motor (fig. 5.18)

For smaller fans and low differential pressure requirements, since the motor power is currently limited to around max. 9 [kW].



Fig. 5.18. Fan with external rotor motor



Fig. 5.19. Fan with belt drive

R: Belt drive (fig.5.19, 5.20)

- Mainly used for industrial applications. The speed can be adjusted to any desired operating point. Subsequent corrections to the operating point can be made at any time. With a suitable design, it can also be used for high-temperature gases.



Fig. 5.20. Belt-driven axial fan on the base frame

K: Drive via elastic coupling (fig. 5.21)

This is generally used for large and heavy impeller designs in the process engineering industry. The fan and motor

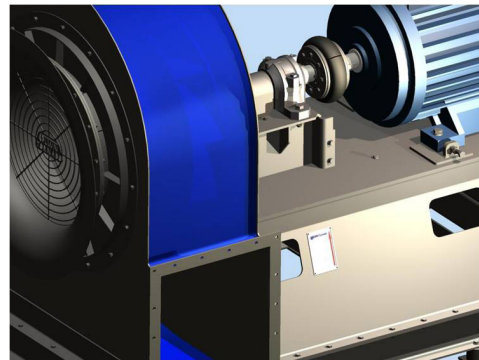

Fig. 5.21. Image – Coupling drive

bearings are independent. The task of the coupling is to transmit large torques at a certain speed.

- Axial fans can be operated in both horizontal and vertical configurations. This must be determined in advance in order to be able to take the different bearing loads into account.

5.4 Radial fan

The radial fan is characterised by higher compression (available pressures). The gas medium goes in along the impeller axis of rotation and is blown out again at a 90° angle to the axis of rotation.

5.4.1 Construction and function

As it was said above, centrifugal impellers can be with forwarding and backward curved blades. The main difference is in the pressure level and in the ratio of static and dynamic pressures. Backward curved blades have lower pressure coefficients (usually not higher than 1,1) but the higher part of static pressure in total on the outlet. On the contrary, centrifugal impellers with forwarding curved blades have higher pressure coefficients (usually higher than 1,5) but much higher part of dynamic pressure on the outlet.

The radial fan essentially consists of (fig. 5.22):

- Casing (it can be a scroll, inline, box etc.);
- Inlet nozzle;
- Impeller, in different versions (types);
- Supports.

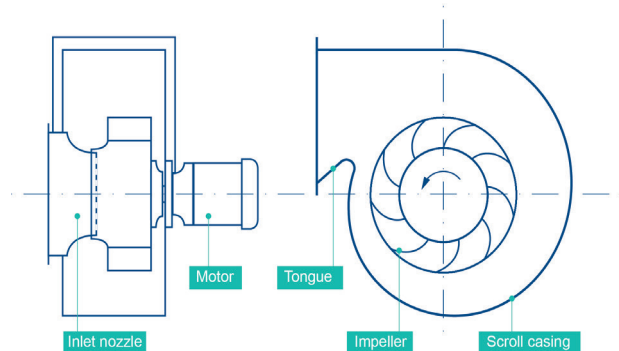

Fig. 5.22. Example of centrifugal fan with scroll casing

The gas (air) enters through the inlet nozzle, goes in the impeller and turns in a radial direction (90°). The energy conversion takes place in the impeller (in the blade channels), i.e. the mechanical energy input via the driveshaft is converted into pressure and velocity energy (potential and kinetic energy).

The scroll casing has two tasks. First, it collects the air exiting from the impeller and guides it to the outlet. Second – due to the constant increase cross-section, a proportion of the dynamic pressure is converted into static pressure. This is called the diffuser effect.

The narrowest point between the scroll casing and the impeller is formed by the "Tongue".

The optimised design of the tongue can contribute significantly to lower noise emissions, better efficiency and pressure levels.

Instead of scroll casing, the inline casing can be used. Then, guide vanes on the outlet of the centrifugal impeller are usually placed to convert the dynamical pressure of swirl on the outlet of the impeller into static pressure.

Sometimes centrifugal impellers are used as "free wheel", then only impellers with backward curved blades can be used, while they have a higher part of static pressure on the outlet.

5.4.2 Types of radial impellers

Radial fans can be differentiated by the design and form of the impeller blades. The impellers can be assigned into three main categories.

The impeller blades can be curved forwards or backwards in the direction of rotation or radially ending.

- **Backward curved blades** (fig. 5.23, 5.24). Radial fans with this type of impeller are also known as high-performance fans, because, as it was said above, the part of dynamic pressure on the outlet for this type of fans is rather low and there is not so much loss in the blade channels as with forwarding curved blades.

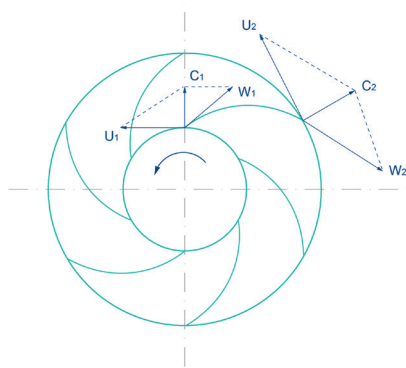

Fig. 5.23. Impeller with backward curved blades with small blade outlet angles

Straight blades angled backwards (fig. 5.24). Suitable for use in radial fans for gases with coarse dry material

particles or fibres; they have good efficiency and are therefore also known as "high-performance transport fans".

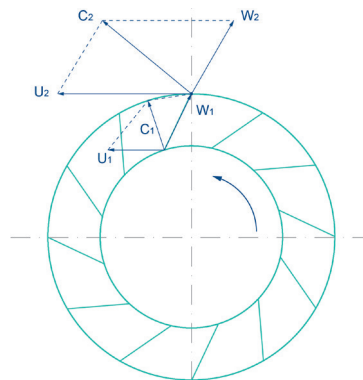

Fig. 5.24. Impeller with backward curved straight blades

- **Blade outlet angle < 90°**

Radially ending impeller blades (fig. 5.25, 5.26), are a sub-form of the type named above and are mainly used without a cover plate, i.e. openly, in transport fans.

The substances to be transported to silos or storage facilities are cereal grain, plastic granulate, woodchips, wood pellets or similar.

Impellers showed on fig. 5.25 create the same transport flow and the same pressure increases in both directions and are therefore used as cooling-air wheels in electromotors, for example.

Blade outlet angle = 90°



Fig. 5.25. Impeller with radially ending blades :

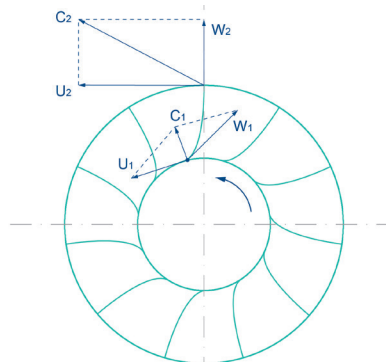

Fig. 5.26. Impeller with radially ending impeller blades

- **Forward curved blades** (fig. 5.27). The proportional velocity energy is very high, the hydraulic efficiency usu-

ally is rather low, – so this type is only used for special purposes, in the marine sphere and in small radial fans. Blade outlet angle from $> 90^\circ$

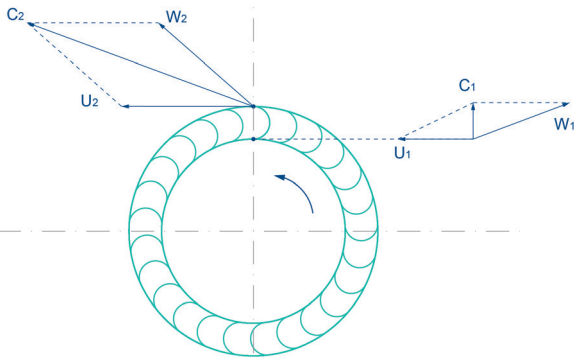

Fig. 5.27. Impeller with forward curved blades.

5.4.3 Configuration of radial fans

Configuration of radial fans is generally performed according to the following criteria and the corresponding requirements of the application.

- **Impeller construction.**

The pressure of the impeller is determined by the construction of the impeller blades according to Point 5.4.1.

Impeller performance is determined by the key geometrical parameters. The discharge width b_2 of the impeller determines the maximum airflow, which can be reached. But width cannot be made too big, while there can appear separation of flow from the cover plate and that leads to the losses of pressure and airflow. The suction diameter is usually determined by the airflow and the velocities in the suction hole on the working point.

Impellers of centrifugal fan can be single (fig. 5.28) or double (fig. 5.29) to reach higher airflows.

A very important place of centrifugal fan construction is the connection between nozzle and impeller. For example, for impellers with big widths, it is important to input high-velocity jet in the gap between nozzle and impeller to prevent separation of flow from the cover plate. And for high-pressure fans, it is better to make labyrinth seal between nozzle and impeller.

R: Single inlet radial impeller Z: Double inlet radial impeller

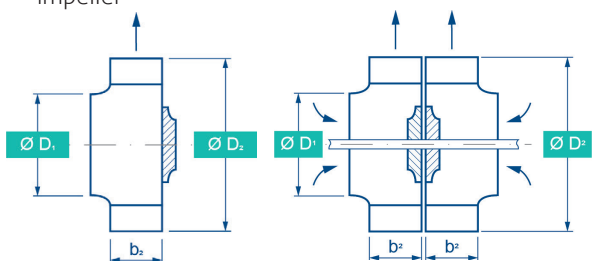

Fig. 5.28. Single inlet radial impeller Fig. 5.29. Double inlet radial impeller

The construction is described in VDMA 24164. Classification is performed using the criteria type designation, connection, drive and housing positions, as shown below:

- **Connection of the fan (type of suction, table 5.3)**

- U: direct connection with duct
- E: with inlet nozzle
- S: with suction box

- **Drive**

M: Impeller directly on motor stub shaft (fig. 5.30)

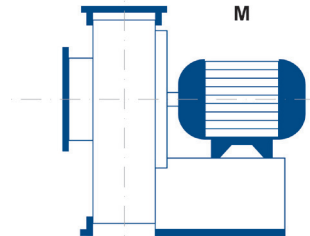

Fig. 5.30. Drive M

K: via elastic coupling (fig. 5.31)

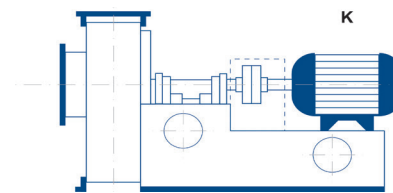

Fig. 5.31. Drive K

R: via belt (fig. 5.32, 5.33)

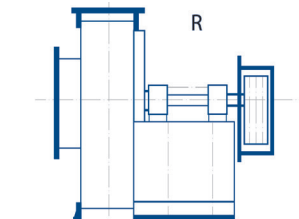

Fig. 5.32. Drive R

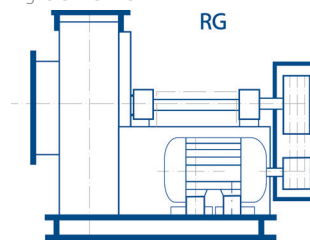

Fig. 5.33. Drive RG

Casing position and direction of rotation. According to a recommendation in the Eurovent Document 1/1 from 5.3975, the following definitions apply for directions of rotation and casing positions for fans :

- **Directions of rotation (fig. 5.34)**

RD = Right-hand rotation, when the impeller – viewed from the drive side – turns clockwise.

LD = Left-hand rotation, when the impeller – viewed from the drive side – turns anticlockwise.

For double inlet radial fans with an external rotor motor built into the impeller, the direction of rotation is determined by the connection side (where the belt is connected).

Type	Connection	Drive
R	U	M
Single inlet	Direct duct connection	Impeller directly on the motor shaft
Z	E	K
Double inlet	With inlet	Via coupling
	S	R
	With suction	Via belt

Table 5.3

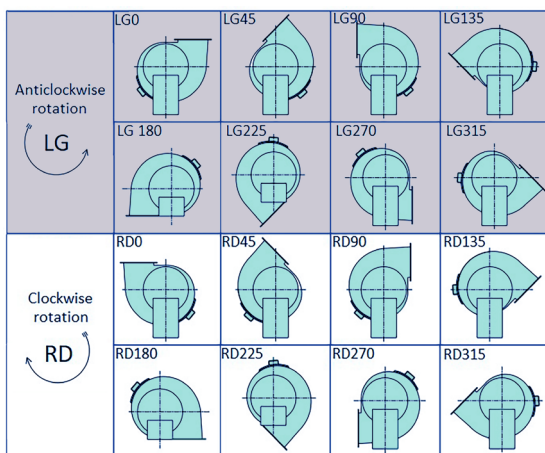

Fig. 5.34. Fan casing orientations

The designation of the angular position of radial fans is determined by the reference axis at right angles to the fixation plane (fig. 5.35).

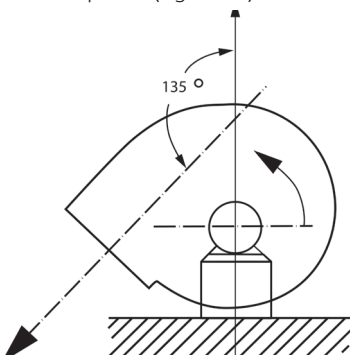

Fig. 5.35. Reference axes

5.4.4 Special design and special constructions

Radial fans for different purposes:

- General-purpose fans. Standard fans for gas temperatures up to 55 [°C]
- Fireproof fans
- Chemical fans
- Explosion-proof fans
- Free wheel
- Roof fans
- Multistage fans

Reversibility is usually achieved by the casing and construction of the impeller. Construction is usually very complicated in comparison with axial fans and used not so widely.

Fireproof centrifugal fans are usually made with scroll casing and some special improvements for shaft cooling.

Chemical fans are made from special plastic or from special stainless steel.

For explosion-proof special motors are used and right couples of materials for moving and fixed parts.

Freewheel is a special type of construction of radial fans which do without casing and is increasingly used in many sub-sectors of ventilation technology.

Free-running radial fans as a single inlet version, used where large quantities of air must be moved against overall pressures ≤ 2.500 [Pa].

They are used, for example, in the following systems:

- Drying plants
- Painting plants
- Clean room systems
- Re-cooling systems
- Central controllers for ventilation and air conditioning applications

Radial roof fans. Radial impellers with backwards curved impeller blades are used most frequently, which are characterised by the essential properties of a high-performance radial fan. The outlet direction is determined by how the fan is to be used. The application of radial roof fans in ventilation and air conditioning applications has become considerably more popular in recent years. These fans are suitable for both horizontal and vertical exhaust gas outlet directions.

Vertical outlet direction (fig. 5.36)

- Odorous exhaust gas (kitchens)
- Toxic exhaust gas (garages)
- Aggressive exhaust gas (process exhaust gas, combustion fumes)
- Thermally-charged exhaust gas (hot gases or combustion fumes)



Fig.5.36. Roof fan with vertical outlet direction

Horizontal outlet direction (fig. 5.37)

- "Normal" uncontaminated exhaust gas
- Uncontaminated industrial exhaust gas
- Residential exhaust gas



Fig. 5.37. Roof fan with horizontal outlet direction

Advantages of the radial roof fan

- Easy to install
- No space requirement within the building
- Inexpensive
- Simple routing of airflow
- Simple to control
- Maintenance-free and corrosion resistant
- Simple construction, high functional reliability
- Exhaust hoods and weather protection grids are unnecessary
- Stable system characteristics (impeller blades curved backwards)
- Stable operating behaviour due to steadily increasing system characteristic
- Integration in heat recovery systems

Disadvantages of the radial roof fan

- Limited pressure boosting (lack of spiral housing)
- Acoustic measures are required for larger pressure increases
- Limited overall efficiency (lack of spiral housing)
- Subsequent increases to volume flow are only possible to a limited extent

5.4.5 Dust and wear operation

For exhaust and process fans, dust and wear must not be underestimated. This must already be taken into account during the design phase.

The dust accumulation and its density, structure, particle size and moisture content are important factors. The uncertainty regarding the adhesive behaviour of dust and/or solid particles determines the application of the fans.

• Key

- F_N = Force in normal direction
- F_Z = Centrifugal force
- T = Force in tangential direction
- R = Frictional force = $F_N \cdot \mu$
- μ = Coefficient of friction

• Transporting dust and fibrous product

Backward curved impeller blades

$R > T$ dust sticks. (fig. 5.38)

- Only suitable in certain cases

Radially ending impeller blades

$R < T$ the dust is spun away. (fig. 5.39)

- Suitable for dirty industrial applications

Straight impeller blades, without a cover plate

$R < T$ fibrous particles slide off. (fig. 5.40)

- Especially suitable for pneumatic transport of fibrous product or bulk
- Fan wear.

If the fan flow is contaminated by material particles or particulate, wear will occur on the impeller and the inside of the housing.

This abrasion alters the surfaces. Corrugations, scoring, scratches and pitting result from this “micro-cutting” process. This results in a not insignificant loss of material

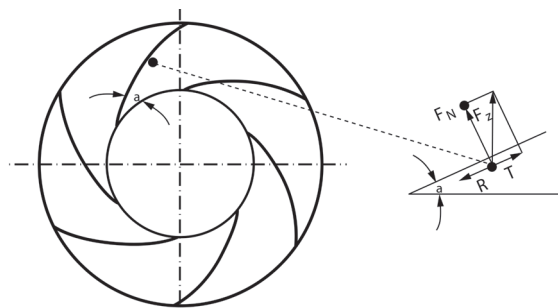

Fig. 5.38. Backward curved impeller blades

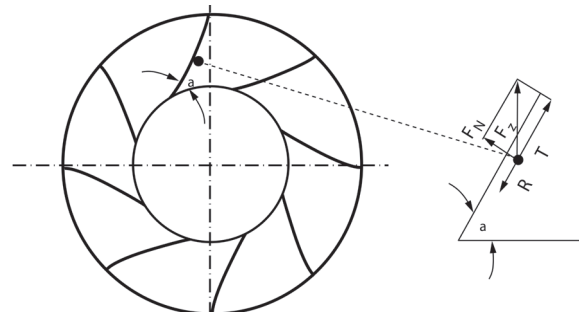

Fig. 5.39. Radially ending impeller blades

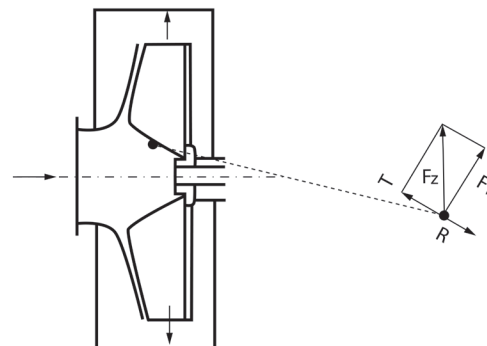

Fig. 5.40. Straight impeller blades, without cover plate

and therefore a weakening of the structure.

Furthermore, material losses on the impeller lead to uneven distributions of mass, resulting in vibrations and imbalance.

5.5 Diagonal fan

The so-called diagonal impeller (or mixed-flow impeller) occupies an intermediate position between axial impellers and radial impellers with backward curved blades (fig. 5.41). The layout of a fan with diagonal impeller gives an airflow similar to the widely used axial fans, at the same time achieving higher static pressure. Thus diagonal impellers are used in inline fans when axial fans have too low pressure and radial fans have too low airflow.

5.5.1 Construction and function

The gas medium goes in along the impeller axis of rotation and is blown out again at some angle to the axis of rotation.

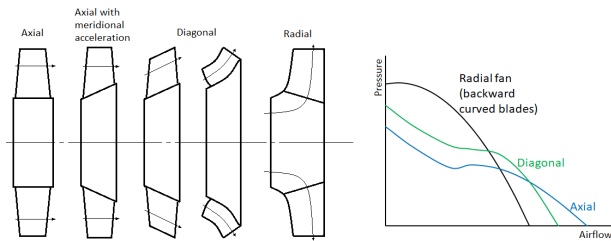

Fig. 5.41. Diagonal impeller

The hub of diagonal fan is conic (fig. 5.42) like for the axial fan with meridional acceleration (fig. 5.43), but on the contrary to the axial fan with meridional acceleration, the outer diameter of the fan casing is also increasing from inlet to the outlet. Vortex formation is minimized of the conical shape of the impeller hub. The air is sucked in an axial direction and goes out in a diagonal direction – this leads to an easier usage in inline fans because the losses in the turn are not so big in comparison with the situation when radial impellers are used.

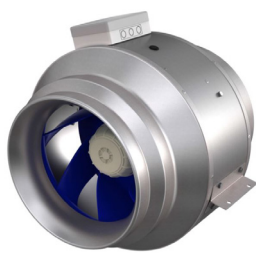

Fig. 5.42. Fan with diagonal impeller



Fig. 5.43. Axial fan with meridional acceleration

The construction is close to the radial inline fans. Usually, guide vanes are situated downstream from the diagonal impeller to restore dynamical pressure from the swirl on the outlet of the impeller (fig. 5.44).

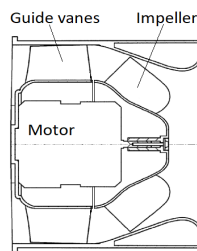

Fig. 5.44. Fan with diagonal impeller

But diagonal impeller also can be used without guide vanes on the outlet, just in the box, like radial impeller (fig. 5.45).



Fig. 5.45. Fan with diagonal impeller

5.6 Crossflow fan

Crossflow (or tangential-flow) fans stand, perhaps, in the third place after radial and axial fans according to the width of their application. The widest cross-flow fans are used in air-heat curtains, household fans-electric heaters and indoor units of air conditioners. The main advantage of cross-flow fans is relatively high airflow on the outlet of a free-running fan with a small diameter and a large axial length of the impeller. This makes it possible to design a piece of “flat” equipment that distributes air through a long narrow slit (fig. 5.46).



Fig. 5.46. Air curtain with crossflow fan

5.6.1 Construction and function

From the aerodynamic point of view, the cross-flow fan is a fan with a very complicated flow, characterized by separation zones and vortices of considerable size, which ultimately determine the aerodynamic characteristics of the fan. The typical internal geometry of the fan and the flow pattern in it in the cross-section plane perpendicular to the impeller axis are shown in fig. 5.47. The fan has an inlet with an inlet sector defined by the inlet arc angle. The impeller of the fan in this plane is similar to the impeller of the radial fan with strongly forward curved blades. Along the axis of the impeller, a fan has a constant shape and is limited by the length of the impeller. The output part of the housing is very similar to the scroll casing of the radial fan. The input and output of the fan divided, on one hand with the part which is called tongue, on the other hand, the beginning of the spiral exit. The fan sometimes is called diametrical, because the flow crosses the impeller across the diameter.

It can be said that the fan comprises two stages: in the first stage, the flow from the fan inlet passes through the blade system inside the wheel, and in the second – through the blade system from the inside of the wheel outwards. In some designs of a cross-flow fan, inside of the impeller guide vanes are situated.

The second stage has a flow similar to the flow in the radial fan with forward-curved blades. Thus, the same blade system in the first and second stages behaves differently from the point of view of aerodynamics, since the flow

passes it first in one and then in the other direction. In this case, a characteristic feature of the flow in the cross-flow fan is the presence of two vortex zones.

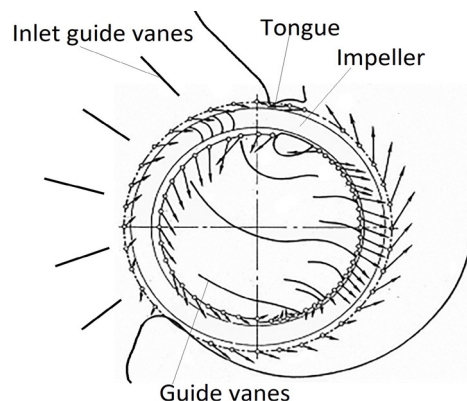

Fig. 5.47. Crossflow fan cross-section

These zones may be more or less intense, different in size, may slightly change their location, more or less enter into the impeller or casing, but are necessarily present, because in these places it changes to the opposite direction of flow through the blade system.

Cross-flow fans can provide coefficients of airflow of up to 1,1 and the coefficients of total pressure up to 4 or more, i.e. more than the radial and axial fans. However, due to the presence of a developed vortex flow structure at all operating modes and suboptimal flow regimes in the corresponding zones of the impeller, the cross-flow fans have a lower efficiency than axial and radial fans. But cross-flow fans can be made with long impellers and create a “flat” fan installation. This determined the main application of diametrical fans in air-heat curtains. Curtains are designed for installation in doorways of small and medium size, they are suspended, as a rule, above the doors and create a slotted downward jet. They use long impellers (one or two wheels on an electric motor with two shaft ends). The aerodynamic load is usually small-an electric or water heat exchanger (a coarse air filter can still be installed), so the fan works, as a rule, on the right branch of the aerodynamic characteristics (at large values of the airflow). The maximum use of the fan abilities is to create a high-speed jet at the outlet to prevent the penetration of outside air into the doorway. On the market, there are a lot of curtains of various designs based on such fans. It is important to pay attention to what jet speeds created by such curtains. The contradiction is that to ensure the required speeds at the fan outlet, it is necessary to provide the appropriate impeller speeds, which can lead to increased noise and vibration of the fan. Therefore, there are often curtains based on cross-flow fans with low jet speeds and not very effective.

5.7 Installation of fan and rotating stall

Fans are often installed in such a way that the flow conditions in front of them and behind them are not ideal. The losses occurring, as a result, depend on the installation and are therefore known as installation losses.

Before designing a fan, the connections on the suction and pressure sides must be determined. If this knowledge is not taken into account system-installation effects will result, which have a severe negative influence on the performance. These effects normally result from the swirl at the inlet, overly short, straight channels at the outlet, and pressure losses in the elastic supports at the inlet and outlet.

More information about the influence of inlet and outlet elements on the fan characteristics will be presented in chapter 6.

Installation of the fan influence not only on the aerodynamic characteristic of the fan but also on vibration and level of noise. In some cases, there can appear rotating stall effects. Rotating stall effects are very strong in axial fans (big angles of installation) and in radial fans with forward-curved blades (in radial impellers with backward curved blades rotating stall is not so strong).

A rotating stall can be connected with high inlet turbulence of flow or/and with a low level of airflow. When the airflow becomes lower, the angle of attack increases. When it becomes too high separation of flow appears (for axial fans usually on the periphery of the blade). However, because of a slight asymmetry of the flow, the separation appears not in all the blade channels simultaneously but only in the group (groups) of channels (fig. 5.48). When separation of flow appears in one channel, airflow moves to another channel and the angles of attack in that channel decreases. That results in moving zones of separation of flow and it is called a rotating stall. High-frequency pulsations of pressure appear and it may cause the destruction of the impeller. Almost the same thing happens in radial fans with forward-curved blades.

You shouldn't mix stall effects in the fan with surge effects since the surge effect is connected with the interaction of a fan with the net on which it is working.

For more details see p.7.4.

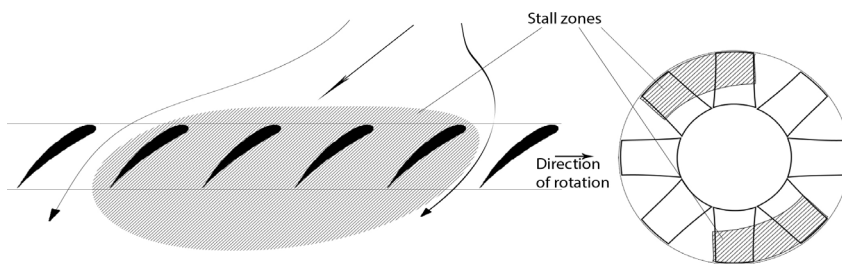

Fig. 5.48. Stall in axial fan

6. The fan in the system

The requirement for the perfect function and cost-effective operation of ventilation equipment is, among other things, the correct planning and design of the duct network i.e., above all, a reliable estimation of the pressure losses.

The pressure losses are primarily determined by the specified duct lengths as well as by the selection of the air velocities and the duct cross-sections. The specification of transition and form pieces also has an influence on the pressure losses and therefore on the operating costs. Dependency of pressure losses in the duct system from the airflow is known as the system characteristic. Correct information about system characteristic is very important for the ideal configuration or selection of fans in the system.

The flow-through ventilation system can usually be regarded as incompressible, i.e. of constant density. Reliable

knowledge of the resistance coefficients of straight ducts and form pieces is absolutely crucial for accurate estimation of the pressure losses. It is often the case that, in the numerous calculation programs available, the changes to the resistance coefficients and parameters where components follow each other in quick succession is not taken into account. This may result in false estimations of the pressure losses.

i Note: at very high pressures, the influence of the compressibility of the air must not be neglected. According to VDI 2044, the influence should be taken into account from approximately 3000 [Pa] as the error here is already 1 [%].

In addition, form pieces which are situated on the inlet or outlet of the fan can strongly influence its aerodynamic characteristic.

6.1 Characteristic diagrams, general

Introducing ISO 5801, AMCA 210, DIN EN ISO 5801 and 24166, and the new version of VDI 2044, provided a uniform definition of what should be understood by a fan characteristic, that is at least the functional correlation between the total pressure increase Δp_t and the sucked-in airflow V .

The curves for the power requirement and the efficiency are also relevant, as a curve for noise emission. For completeness, the speed, gas density and certain fan dimensions must be specified to define the operating behaviour.

Precision class	0	1	2	3
Airflow	± 1 %	± 2,5 %	± 5 %	± 10 %
Pressure increase	± 1 %	± 2,5 %	± 5 %	± 10 %
Motor power	+ 2 %	+ 3 %	+ 8 %	+ 16 %
Efficiency	- 1 %	- 2 %	- 5 %	—
Sound pressure level (A)	+ 3 [dB]	+ 3 [dB]	+ 4 [dB]	+ 6 [dB]

Table 6.1. Excerpt from DIN 24166 (precision categories)

For a thorough assessment of the characteristic diagrams, it is essential that the dimensional tolerances are also considered, e.g. according to DIN 24166 or by specifying the precision categories (table 6.1-6.2). This may become very important in a disputed warranty case.

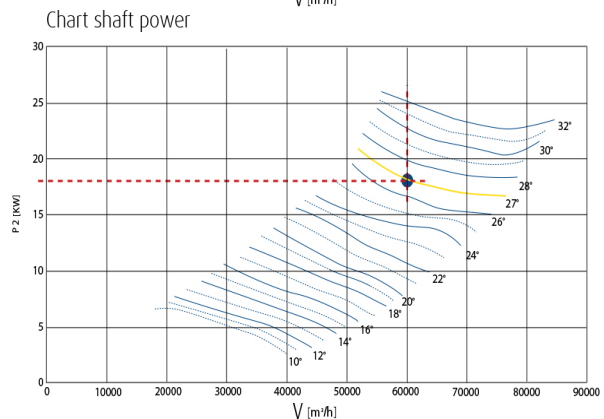
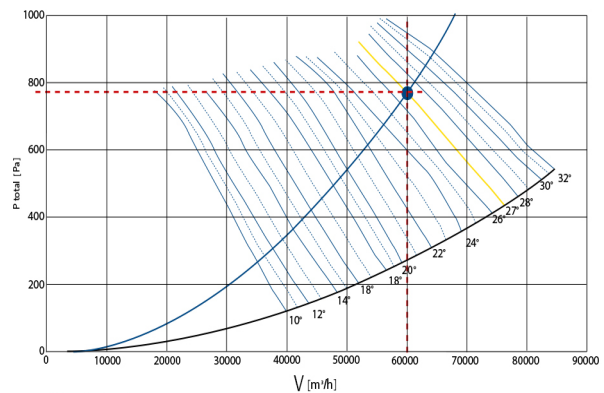

Fig. 6.1. Standard set of characteristic curves of a fan with design point achieved on AMCA test facility

Class	Area of application	Performance
0	Mining (eg main fan), process engineering, power plant, wind tunnels, tunnels, etc.	> 500 [kW]
1	Mining, process engineering, power plant, wind tunnels, tunnels, ventilation and air conditioning systems.	> 50 [kW]
2	Ventilation and air conditioning systems, process engineering, industrial fans, power plants fans and industrial fans for harsh operational conditions regarding wear and corrosion.	> 10 [kW]
3	Ventilation and air conditioning systems, sawdust exhausters, agricultural engineering, small fans, power plants fans and industrial fans for harsh operational conditions regarding wear and corrosion.	—

Table 6.2. Excerpt from DIN 24166 (precision categories)

6.2 System and fan curves

The operating point of a fan results from the intersection of the system characteristic and the fan characteristic (fig. 6.1). At this intersection, there is a balance between the system pressure and the output pressure of the fan at a certain airflow. The operating point rarely coincides with the optimum point (point of maximum efficiency) of the fan.

The intersection of the fan characteristic with the dynamic pressure line is the maximum airflow of the fan which it would deliver against “zero system resistance”.

Fan performance data is usually specified in the form of characteristic curves or diagrams. These are standard characteristics determined at great expense on standard test rigs according to DIN EN ISO 5801 or ISO 5801, AMCA 210, i.e. uninterrupted, intake and discharge connection conditions.

It is often forgotten that if the system is installed unfavourably, particularly if there are disturbances on the intake side, the installation characteristic of the fan can transform regarding the standard characteristic (fig. 6.2).

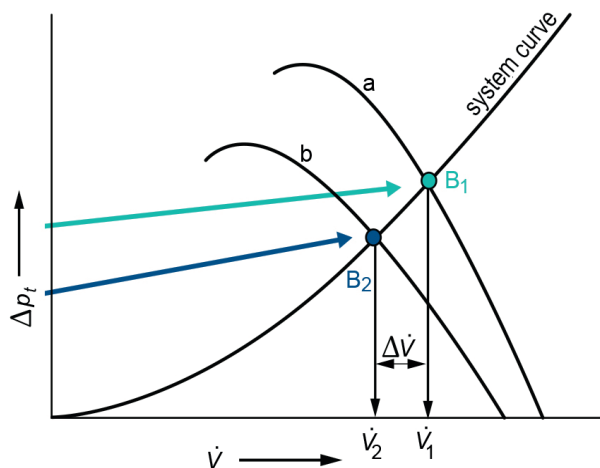

- B_1 operating point for standart characteristic
- B_2 operating point for installation characteristic
- a standart characteristic
- b installation characteristic
- \dot{V} airflow

Fig. 6.2. Standard characteristic and installation characteristic of a fan

It is essential that the fan manufacturer’s installation instructions are observed if the target operating parameters are to be maintained.

6.2.1 Inlet and outlet disturbances

The inlet disturbances listed below should be avoided, as these lead to massive airflow disturbances and /or pressure losses.

Inlet nozzles (fig.6.3) at fan intakes should ensure the flow into the impeller is a swirl-free as possible, with

a smooth speed; which is important for the entry to axial machines. If there is no inlet nozzle, as shown on fig. 6.4-6.5, turbulence results due to the sharp-edged flange, as illustrated. The flow is constricted, resulting in unfavourable loads on the impeller blades. This results in, among other things, a severe reduction in performance, i.e. the fan characteristic from the test set-up measurement which is specified in the characteristic datasheet is not achieved.

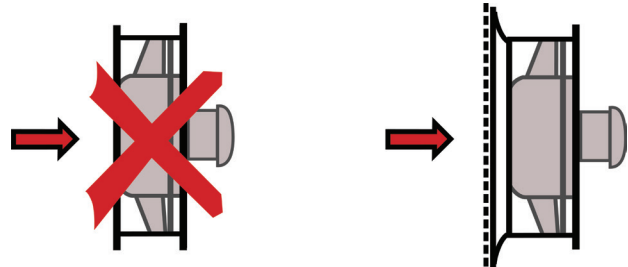

Fig. 6.3. Inlet nozzle

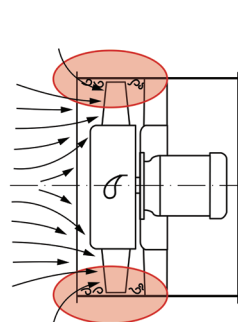

Fig. 6.4. Free-intake fans without inlet nozzle - Axial

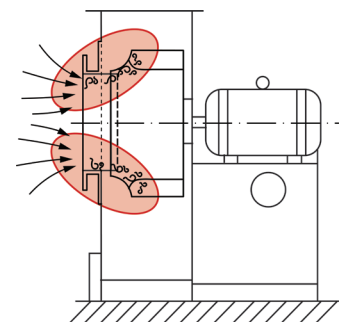

Fig. 6.5. Free-intake fans without inlet nozzle - Radial

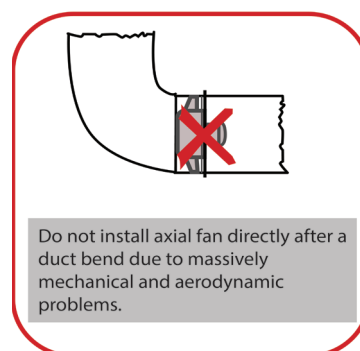

Fig. 6.6. Fan after duct bend

For almost the same reason, fa an should not be positioned after the bend (fig. 6.6-6.7). Separation of flow and swirl after the bend will cause the decrease of fan aerodynamics and additional loads on blades.

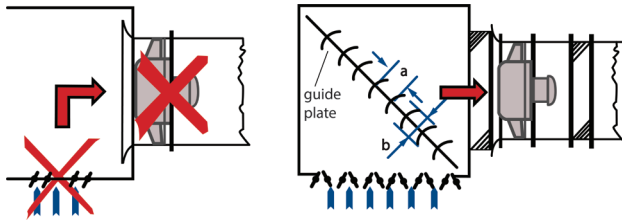

Fig. 6.7. Fan after intake chamber

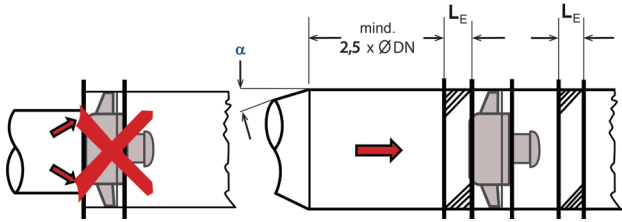

Fig. 6.8. Duct installation with constriction

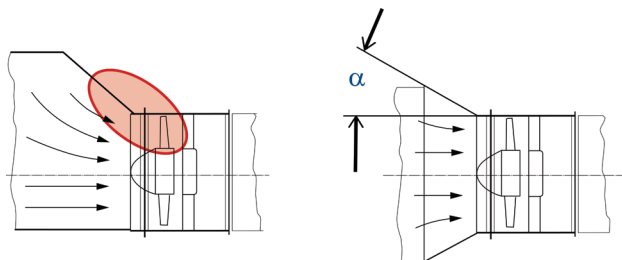

Fig. 6.9. Duct installation with one-sided opening angle#

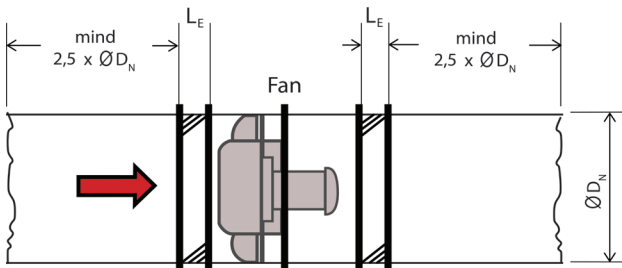

Fig. 6.10. Duct installation

When the fan is used with the duct on the inlet and on the outlet, there should not be a change in the cross section of the duct close to the fan inlet or outlet (fig. 6.8-6.9). An optimum variant is to have at least $2,5D_N$ length of the straight duct before and after the fan (fig. 6.10).

The one-sided mechanical loading of individual impeller blades – due to turbulence resulting from the installation – may eventually destroy the impeller.

In some cases, the influence of the elements, which are on the inlet or outlet can be calculated in advance.

The following applies for the calculation:

eq. 6.2.1-01

$$\Delta p_{\text{sys}} = \zeta_{\text{sys}} \cdot p_d \quad [\text{Pa}]$$

Δp_{sys} : Installation pressure loss [Pa]

ζ_{sys} : Installation factor (pressure loss – coefficient)

p_d : Dynamic pressure on the fan's suction-side or pressure-side connection [Pa]

- Suction side installation factors (installation pressure losses)

Example a (fig. 6.11):

Installation factor of 90° round elbow at fan inlet

Examples b – d (fig. 6.12):

Installation factors of 90° bends with round cross-section at fan inlet

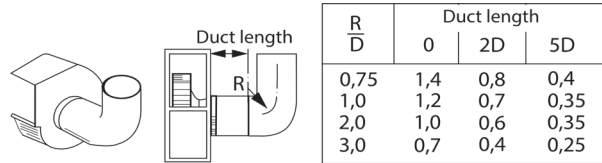
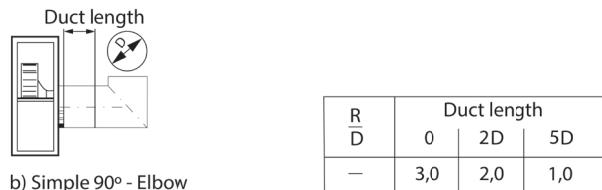
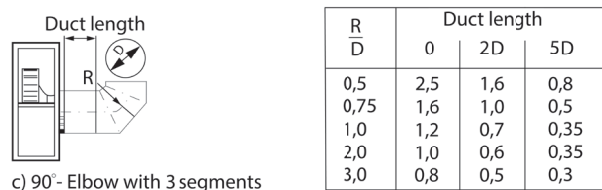

Fig. 6.11.



b) Simple 90° - Elbow



c) 90° - Elbow with 3 segments

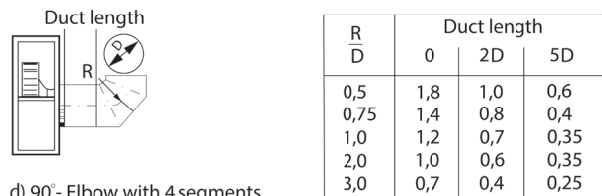

d) 90° - Elbow with 4 segments

Fig. 6.12.

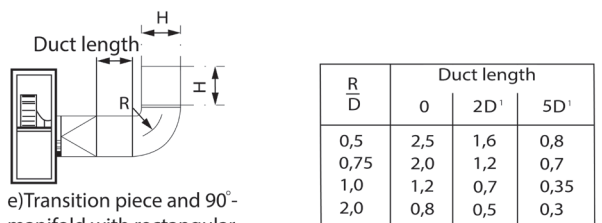

e) Transition piece and 90°-manifold with rectangular cross-section without baffles

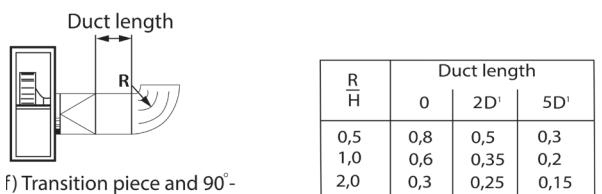

f) Transition piece and 90°-manifold with rectangular cross-section and 3 long baffles

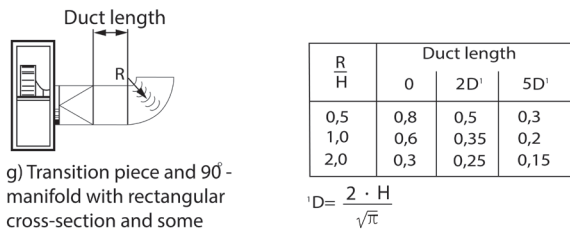

g) Transition piece and 90° manifold with rectangular cross-section and some short baffles

The free cross section of the square channel (H x H) is as large as the free cross section of the fan suction ($H^2 = \pi \cdot D^2/4$).
The maximum opening angle is 15° at constant cross-section constriction (confusor), with continuous cross-sectional widening (diffusor) 7,5°.

Fig. 6.13.

Examples e – g (fig. 6.13):

Installation factors of a transition piece and a 90° bend with a rectangular cross-section and without guide plate at fan inlet.

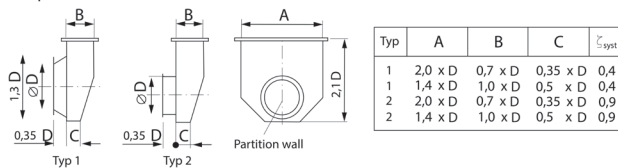

h) Installation factors for fan inlet boxes

Fig. 6.14.

Example h (fig. 6.14):

Installation factors for fan depression pockets.

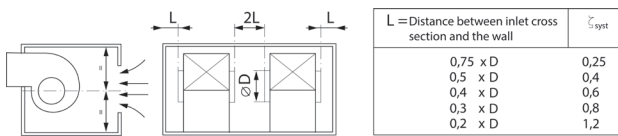

k) Installation factors for free inlet fans with limited space around the fan inlet

Fig. 6.15.

Example k (fig. 6.15):

Installation factors for free-inlet fans with limited space around the fan inlet.

- Pressure side installation factors (installation pressure losses)

Example l (fig. 6.16):

Fully effective channel length L_{E100} for axial and radial fans.

Speed profiles at the fan outlet influence the pressure drop in the subsequent components of the system. The actual outflow cross-section A_E and the connection cross-section A_N determine the speed profile.

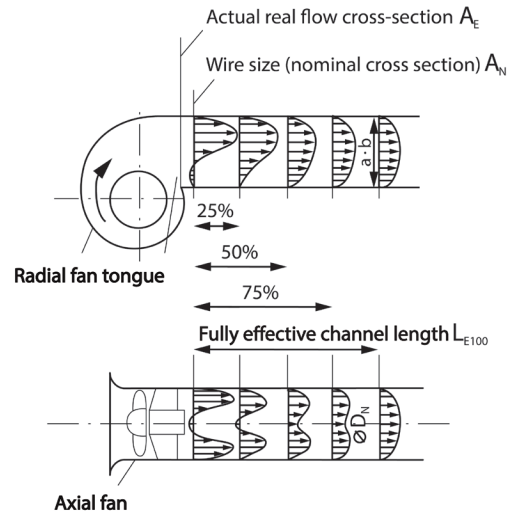

The fully effective channel length is defined as follows:
2,5 x nominal cross section - diameter D_N for speeds up to 12 m/s.
Additionally 1 diameter for each supplementary 5 m/s.
On channels with a rectangular cross section with the sides a and b
the equivalent channel diameter is $= \sqrt{\frac{4 \cdot a \cdot b}{\pi}}$

Fig. 6.16.

The fully effective channel length L_{E100} is achieved once the velocity profile has become constant.

If the fan installation deviates from the test conditions used to determine the fan characteristics, further installation factors must be taken into account:

Examples m + n (fig. 6.17):

The channel at the fan outlet is too short.

Irregular speed distribution at the fan outlet (see Example l)

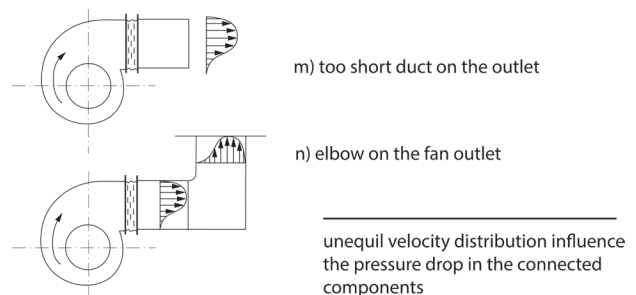

Fig. 6.17.

Example o (fig. 6.18):

90° bends behind the fan outlet in the positions A – D can in part result in considerable installation factors.

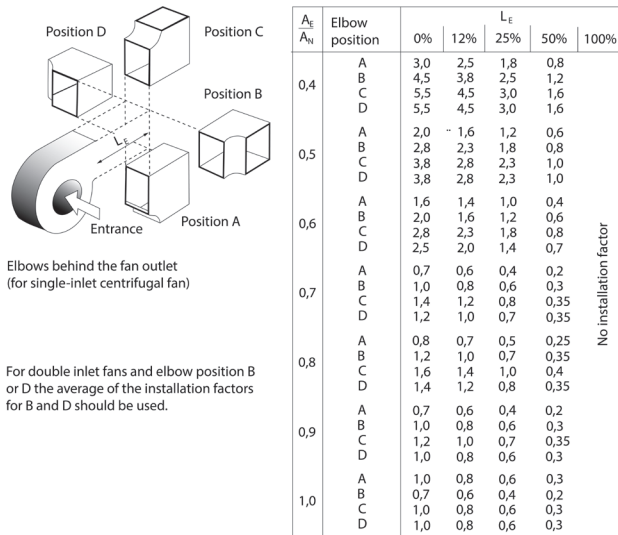

Fig. 6.18.

Example p (fig. 6.19):
Installation losses for shutter dampers directly at the fan outlet.

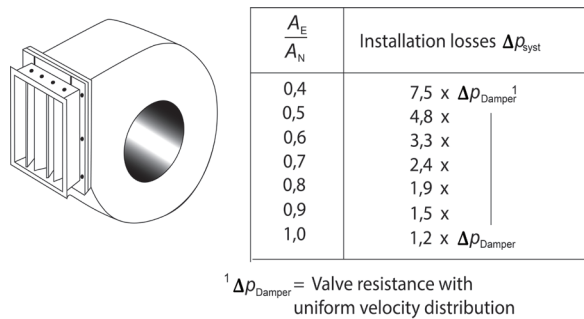

Fig. 6.19.

6.2.2 Diffusers

Free-discharge axial and radial fans have significant kinetic energy (= dynamic pressure) in the discharge cross-section, which is regarded as a loss. The discharge speed directly determines the extent of the losses, therefore it is self-evident that the losses can be reduced by reducing the speed. This converts a portion of the kinetic energy (dynamic pressure) into useful energy (static pressure). The system pressure can now be reduced by this portion of the recovered pressure $p_{d2} - p_{d1}$, or the blade angle corrected for axial fans. This results in lower drive powers and a reduction in operating costs.

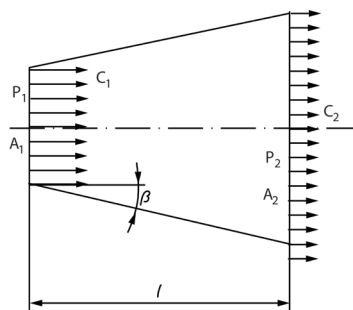

Fig. 6.20. Speed distribution in the diffuser

• **Definition of a diffuser.** The diffuser is a piece of duct which widens constantly toward airflow, in which the flow is decelerated. The quality of the energy conversion in diffusers depends on the inflow conditions. Here, a significant role is played by the flow conditions, such as the impeller outflow, spiral flow and flow after the guide vanes. The opening angle β (fig. 6.20) must remain below certain limit values dependent on the diffuser geometry and the flow conditions, due to the risk of flow separation (fig. 6.21).

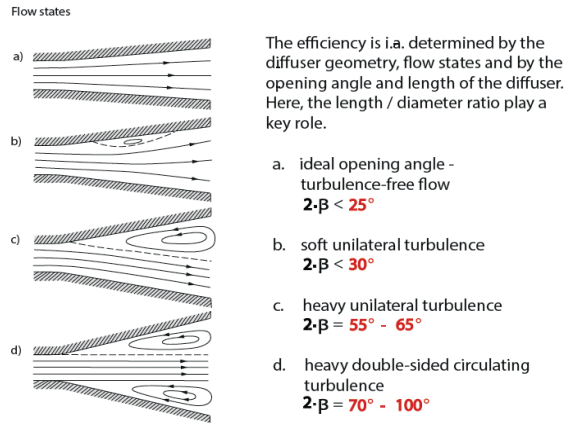

Fig. 6.21. Flow states and limit values (example)

• **Circular ring diffusers.** Circular ring diffusers are those which comprise a rotationally symmetrical outer housing and internal components. Due to their form, these are an ideal supplement to axial fans. Here too, the energy conversion essentially depends on the geometry and flow conditions. The opening angle α (β) should not be larger than 14° because if it will be higher than 18° , the flow starts to separate from the diffuser walls (fig. 6.22).

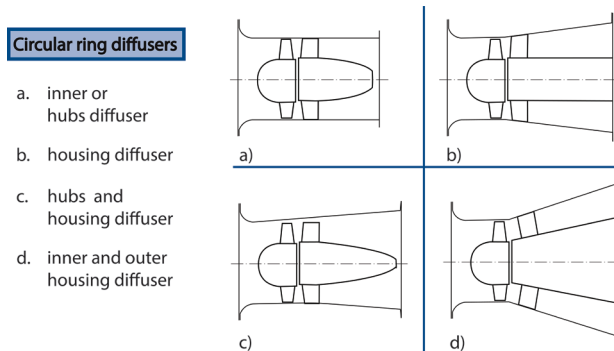

Fig. 6.22. Circular ring diffusers

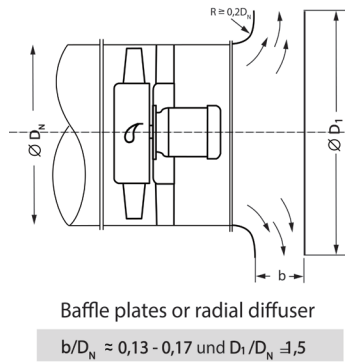

Fig. 6.23. Baffle plates/radial diffuser

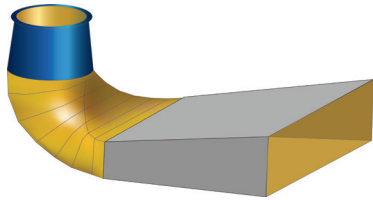

Fig. 6.24. Duct or duct diffuser

These are the most commonly used diffusers in ventilation applications. In addition, there are many types of diffusers used in ventilation and air conditioning which should be mentioned (fig. 6.23-6.24), without going into further detail and making no claim to completeness: Radial fan – impact diffuser, diffusers on cross-flow fans, Carnot impact diffuser, vehicle diffuser, F1-racing diffuser, diffusers in acoustics, etc.

Calculation example

Comparison of a fan with and without a diffuser (fig. 6.25)

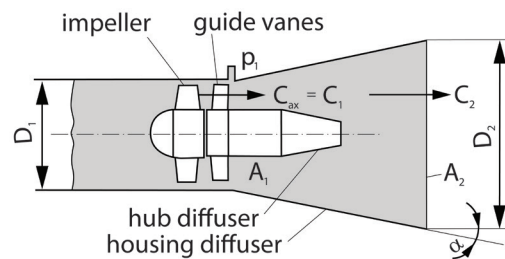

Fig. 6.25. Axial fan with discharge guide vane and hub and housing diffuser

A free discharging fan should fulfil the following operating data:

Without diffuser:

Airflow	V	= 35	[m ³ /s]	= 126 000	[m ³ /h]
Stat. pressure	p_{s1}	= 920	[Pa]		
Air density	ρ	= 1,204	[kg/m ³]		

An axial fan was selected with:

Fan \varnothing	D_1	= 1,25	[m]
Speed	n	= 1450	[1/min]
Efficiency	η	= 80,8	[%]
Dyn. pressure	p_{d1}	= 880	[Pa]

eq. 4.2-01	p_t	= $p_s + p_{d1}$	[Pa]
Total pressure	p_t	= 920 + 880	[Pa]
	p_t	= 1800	[Pa]
Blade angle	α_1	= 32	[°]

eq. 6.2.1-02	Power on the shaft without diffuser		
	P_w	= $(V \cdot p_t) / \eta$	[W]
	P_w	= $(35 \cdot 1800) / (0,808)$	[W]
	P_w	= 78	[kW]

Power requirement of the fan with diffuser (fig. 6.26)

Diffuser outlet \varnothing	D_2	= 1,8	[m]
Outlet surface	F_2	= 2,545	[m ²]
Opening angle	$\beta(\alpha)$	= 7	[°]
Efficiency	η_{diff}	= 73	[%]

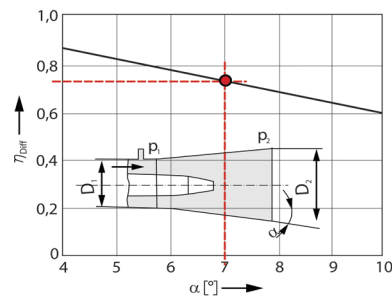

Fig. 6.26. Diffuser efficiency dependent on the opening angle with smooth axial inflow

For the airflow being delivered, the resulting dynamic pressure at the diffuser outlet (2) is:

eq. 3.4.2-01	p_{d2}	= $\rho/2 \cdot c_2^2$	[Pa]
	p_{d2}	= $\rho/2 \cdot (V/F_2)^2$	[Pa]
	p_{d2}	= $0,6 \cdot (35/2,545)^2$	[Pa]
	p_{d2}	= 114	[Pa]

The static pressure recovery can be calculated using the formula:

eq. 3.5-09	Δp_s	= $(p_{d1} - p_{d2}) \cdot \eta_{diff}$	[Pa]
	Δp_s	= $(880 - 114) \cdot 0,73$	[Pa]
	Δp_s	= $(880 - 114) \cdot 0,73$	[Pa]
	Δp_s	= 559	[Pa]

The conversion losses in the diffuser can be calculated as follows:

eq. 6.2.1-03	U_v	= $p_{d1} - p_{d2} - p_s$	[Pa]
	U_v	= 880 - 114 - 559	[Pa]
	U_v	= 207	[Pa]

The required total pressure of the fan-diffuser system is:

eq. 6.2.1-04	p_t	= $p_s + p_{d2} + U_v$	[Pa]
	p_t	= 920 + 114 + 207	[Pa]
	p_t	= 1241	[Pa]

This total pressure and the delivered airflow result in a reduced:

blade angle	α_2	= 26	[°]
efficiency	η_2	= 79,0	[%]

eq. 6.2.1-02 **Power on the shaft with diffuser** (fig. 6.27)

$$P_w = (V \cdot \Delta p) / \eta \quad [W]$$

$$P_w = (35 \cdot 1241) / (0,79) \quad [W]$$

$$P_w = 55 \quad [kW]$$

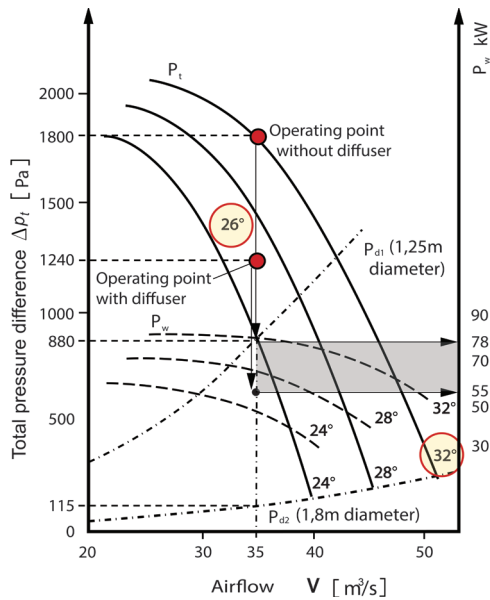

Fig. 6.27. Characteristics for calculation example (dark region = power saving)

The power saving is:

eq. 6.2.1-05

$$P_{WE} = 100 \cdot (P_{WoD} - P_{WmD}) / P_{WoD} \quad [\%]$$

$$P_{WE} = 100 \cdot (78 - 55) / 78 \quad [\%]$$

$$P_{WE} = 29,5 \quad [\%]$$

P_{WE} : Power saving
 P_{WoD} : Power without diffuser
 P_{WmD} : Power with diffuser

Please note:

For free-discharge axial fans, with installation type A + C according to DIN EN ISO 5801, it can be assumed that, depending on the size of the swirling flow at the fan outlet, the results in practice will be different to those calculated theoretically. Exact values can only be determined by measurement.

If there is a minimum swirling flow after the fan, whose dynamic pressure at the operating point is $\Delta p_{d1} > 150$ [Pa], it is worth considering using a diffuser. Because the potential for saving energy and operating costs is huge (see example calculation), it is a sensible contribution to the reduction of the energy requirement and CO₂ emissions.

6.3 The laws of similarity

Laws of similarity (proportionality and affinity laws) are principles derived from physics which can represent the correction of operating data. They are used to determine volumes, differential pressure and drive power for similar but different-sized fans at the same or different speed of rotation. These laws, which in themselves are only theoretically valid, can also be used for real fans (turbomachinery) with sufficient accuracy.

These formulae are used to convert performance data to other operating states. e.g. for speed changes due to a frequency converter or for 60 [Hz] operation.

General formulas are:

eq. 6.3-01 $V_1/V_2 = (n_1/n_2) \cdot (d_1/d_2)^3$

eq. 6.3-02 $\Delta p_1/\Delta p_2 = (n_1/n_2)^2 \cdot (d_1/d_2)^2$

eq. 6.3-03 $P_{w1}/P_{w2} = (n_1/n_2)^3 \cdot (d_1/d_2)^5$

a) Proportionality law (for constant diameter)

eq. 6.3-04 $V_1/V_2 = (n_1/n_2)$

eq. 6.3-05 $\Delta p_1/\Delta p_2 = (n_1/n_2)^2 = (V_1/V_2)^2$

eq. 6.3-06 $P_{w1}/P_{w2} = (n_1/n_2)^3 = (V_1/V_2)^3$

b) Affinity law (for constant speed of rotation)

eq. 6.3-07 $V_1/V_2 = (d_1/d_2)^3$

eq. 6.3-08 $\Delta p_1/\Delta p_2 = (d_1/d_2)^2$

eq. 6.3-09 $P_{w1}/P_{w2} = (d_1/d_2)^5$

Examples of usage of this laws are shown in table 6.3.

Index 1 :	original value (actual state)				
Index 2 :	new value				
Speed	(constant diameter)	Volume		$n_1/n_2 = V_1/V_2$	
Example:	$V_1 =$	25 000	[m ³ /h]	$n_2 =$	$n_1 \cdot (V_2/V_1)$
a)	$n_1 =$	1 500	[1/min]	$n_2 =$	$1500 \cdot (15\,000/25\,000)$
	$V_2 =$	15 000	[m ³ /h]	$n_2 =$	900
	$n_2 =$?			[1/min]
Drive power	(constant diameter)	Speed and volume		$P_{w1}/P_{w2} = (n_1/n_2)^3 = (V_1/V_2)^2$	
Example:	$V_1 =$	25 000	[m ³ /h]	$P_{w2} =$	$P_{w1} \cdot (V_2/V_1)^3$
a)	$P_{w1} =$	6,80	[kW]	$P_{w2} =$	$6,8 \cdot (35\,000/25\,000)^3$
	$V_2 =$	35 000	[m ³ /h]	$P_{w2} =$	18,63
	$P_{w2} =$?		$P_{w2} =$	[kW]
Diameter of the impeller	(constant speed of rotation)	Volume		$V_1/V_2 = (d_1/d_2)^3$	
Example:	$V_1 =$	25 000	[m ³ /h]	$V_2 =$	$V_1 \cdot (d_2/d_1)^3$
b)	$d_1 =$	800	[mm]	$V_2 =$	$25\,000 \cdot (900/800)^3$
	$d_2 =$	900	[mm]	$V_2 =$	36 000
	$V_2 =$?			[m ³ /h]

Table 6.3. Examples of laws of proportionality use

6.4 Dimensionless parameters

Dimensionless parameters are required for the design, comparison and critical assessment of all fans. These figures or values must be dimensionless so they are independent of the relevant pressures, throughout and similar parameters. Resulting from years of development, it is possible to recommend parameters which have proven themselves fit for purpose. The descriptive derivation of these parameters enables a broad range of people to develop an understanding, even without scientific knowledge (table 6.4).

Symbol	Description of dimensionless parameter
η	Efficiency
ψ	Pressure coefficient
ϕ	Airflow coefficient
λ	Power coefficient
δ	Diameter parameter
σ	Run number
τ	Throttle parameter

Symbol	Description	Unit
V	Airflow	[m ³ /s]
Δp_t	Total pressure difference	[Pa]
P_w	Power on the shaft	[W]
ρ	Density of the medium	[kg/m ³]
d_2	Impeller diameter	[m]
u_2	Blade tip speed	[m/s]

Table 6.4. Dimensionless parameters

eq. 6.4-01																
Efficiency	$\eta = (\Delta p_t \cdot V) / P_w$															
η is the ratio of the supplied delivery rate of the fan to the required drive power from the driveshaft and is, therefore, a dimension for rating the degree of energy conversion in the fan.																
Example:	<table> <tr> <td>$V =$</td> <td>5,00</td> <td>[m³/s]</td> <td>$\eta =$</td> <td>$(\Delta p_t \cdot V) / P_w$</td> </tr> <tr> <td>$P_w =$</td> <td>5,70</td> <td>[kW]</td> <td>$\eta =$</td> <td>$(650 \cdot 5) / 5700$</td> </tr> <tr> <td>$\Delta p_t =$</td> <td>650</td> <td>[Pa]</td> <td>$\eta =$</td> <td>0,57</td> </tr> </table>	$V =$	5,00	[m ³ /s]	$\eta =$	$(\Delta p_t \cdot V) / P_w$	$P_w =$	5,70	[kW]	$\eta =$	$(650 \cdot 5) / 5700$	$\Delta p_t =$	650	[Pa]	$\eta =$	0,57
$V =$	5,00	[m ³ /s]	$\eta =$	$(\Delta p_t \cdot V) / P_w$												
$P_w =$	5,70	[kW]	$\eta =$	$(650 \cdot 5) / 5700$												
$\Delta p_t =$	650	[Pa]	$\eta =$	0,57												
eq. 6.4-02																
Pressure coefficient	$\Psi = \Delta p_t / (\rho / 2 \cdot u_2^2)$															
Ψ is a parameter for the total pressure difference which a fan creates, in relation to the peripheral speed of its impeller's external diameter.																
Example:	<table> <tr> <td>$\Delta p_t =$</td> <td>650</td> <td>[Pa]</td> <td>$\Psi =$</td> <td>$\Delta p_t / (\rho / 2 \cdot u_2^2)$</td> </tr> <tr> <td>$\rho =$</td> <td>1,20</td> <td>[kg/m³]</td> <td>$\Psi =$</td> <td>$650 / (0,6 \cdot 98,96^2)$</td> </tr> <tr> <td>$u_2 =$</td> <td>98,96</td> <td>[m/s]</td> <td>$\Psi =$</td> <td>0,111</td> </tr> </table>	$\Delta p_t =$	650	[Pa]	$\Psi =$	$\Delta p_t / (\rho / 2 \cdot u_2^2)$	$\rho =$	1,20	[kg/m ³]	$\Psi =$	$650 / (0,6 \cdot 98,96^2)$	$u_2 =$	98,96	[m/s]	$\Psi =$	0,111
$\Delta p_t =$	650	[Pa]	$\Psi =$	$\Delta p_t / (\rho / 2 \cdot u_2^2)$												
$\rho =$	1,20	[kg/m ³]	$\Psi =$	$650 / (0,6 \cdot 98,96^2)$												
$u_2 =$	98,96	[m/s]	$\Psi =$	0,111												
eq. 6.4-03																
Airflow coefficient	$\phi = V / (u_2 \cdot (\pi \cdot d_2^2 / 4))$															
ϕ is a parameter for the volumetric flow which a fan delivers in relation to its impeller's external diameter and its peripheral speed.																
Example:	<table> <tr> <td>$V =$</td> <td>5,00</td> <td>[m³/s]</td> <td>$\phi =$</td> <td>$V / (u_2 \cdot (\pi \cdot d_2^2 / 4))$</td> </tr> <tr> <td>$u_2 =$</td> <td>98,96</td> <td>[m/s]</td> <td>$\phi =$</td> <td>$5 / (98,96 \cdot (\pi \cdot 0,63^2 / 4))$</td> </tr> <tr> <td>$d_2 =$</td> <td>0,63</td> <td>[m]</td> <td>$\phi =$</td> <td>0,162</td> </tr> </table>	$V =$	5,00	[m ³ /s]	$\phi =$	$V / (u_2 \cdot (\pi \cdot d_2^2 / 4))$	$u_2 =$	98,96	[m/s]	$\phi =$	$5 / (98,96 \cdot (\pi \cdot 0,63^2 / 4))$	$d_2 =$	0,63	[m]	$\phi =$	0,162
$V =$	5,00	[m ³ /s]	$\phi =$	$V / (u_2 \cdot (\pi \cdot d_2^2 / 4))$												
$u_2 =$	98,96	[m/s]	$\phi =$	$5 / (98,96 \cdot (\pi \cdot 0,63^2 / 4))$												
$d_2 =$	0,63	[m]	$\phi =$	0,162												

eq. 6.4-04

Power coefficient $\lambda = \varphi \cdot \psi / \eta$

λ is a parameter for the required shaft power.

Example: $\varphi = 0,162$ $\lambda = \varphi \cdot \psi / \eta$
 $\psi = 0,111$ $\lambda = 0,162 \cdot 0,111 / 0,57$
 $\eta = 0,57$ $\lambda = 0,032$

eq. 6.4-05

Diameter coefficient $\delta = \psi^{1/4} / \varphi^{1/2}$

δ tells us how many times larger the impeller's external diameter is than that of a reference fan with:

eq. 6.4-06

Run number $\sigma = \varphi^{1/2} / \psi^{3/4}$

σ tells us how much faster or slower the impeller is turning compared with the reference fan with:

eq. 6.4-07

Throttle coefficient $\tau = \varphi^2 / \psi$

τ is the parameter for the system parabola in the dimensionless set of characteristic curves.

Table 6.5. Dimensionless parameters

6.5 Selection criteria

After estimation and evaluation of the dimensionless parameters, these are used to define the type of fan construction, nominal size and speed.

The data and values listed in the following diagrams (fig 6.28-6.29) and tables (table 6.6-6.7) may be recommended and can help to make the correct selection.

Overview of fans parameters						
Type	Scheme	φ_{max}	ψ_{max}	σ	δ	
Tangential (crossflow)		1,1	2...6	0,27...0,62	1,13...1,49	
Radial fan	forward curved (big inlet diameter)	1	2...3	0,44...0,59	1,19...1,32	
	Forward curved	0,7 · r _s	0,4	2,2	0,35	1,93
	Backward curved		0,4	1	0,63	1,58
	Forward curved	0,5 · r _s	0,25	1,8	0,32	2,32
	Backward curved		0,16	1,1	0,37	2,56
	Forward curved	0,3 · r _s	0,065	1,7	0,17	4,48
	Backward curved		0,05	1,5	0,16	4,95
	Forward curved/backward curved	0,15 · r _s	0,022	1,3	0,12	7,2
Axial Fan	Small hub	0,2	0,2	1,5	1,5	
	Big hub	0,5	1	0,71	1,41	
	Meridional acceleration	0,5	1,2	0,62	1,48	

Table 6.6. Overview of fans parameters

Types of fans with most important key figures				
Type	Scheme	φ	ψ	Appliance
Tangential (crossflow)		1...2	2...6	High pressure with low space consumption
Radial fan	Backward curved	0,2...0,4	0,6...1,5	At high pressure and efficiencies
	Radially ending	0,3...0,6	1...2	For specific purposes
	Forward curved	0,4...1,0	2...3	High pressure and low efficiencies
	Meridional acceleration	0,2...0,5	0,4...1,2	High pressure, in certain cases
Mixed flow	Diagonal	0,2...0,3	0,4...0,6	Duct installation
Axial Fan	Wall fan	0,1...0,25	0,05...0,1	For windows and wall mounting
	Impeller without guide vanes	0,15...0,3	0,1...0,3	For lower pressure
	Impeller with guide vanes	0,3...0,6	0,3...0,6	For medium pressure
	Counterrotating	0,2...0,8	1...3	High pressure in certain cases

Table 6.7. Types of fans with most important figures

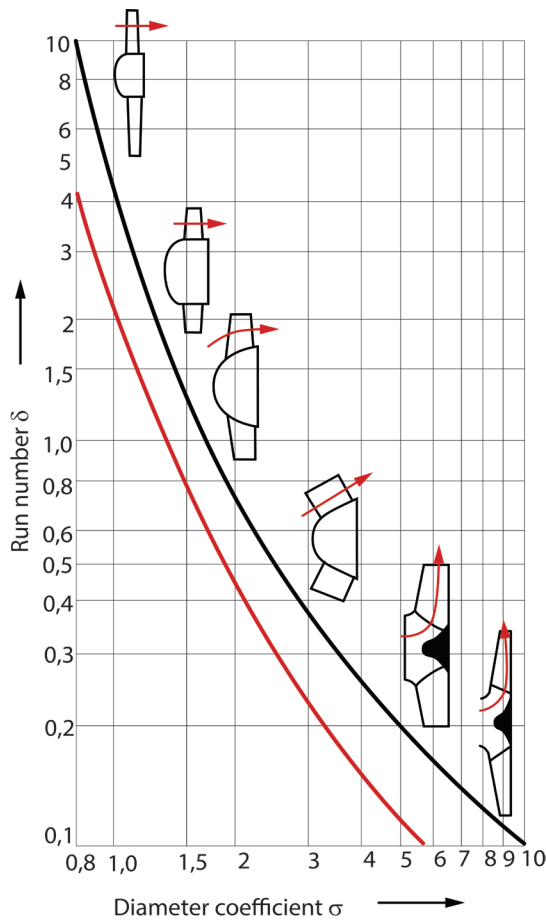

Fig. 6.28. Dependence of run number from diameter coefficient for different types of fans

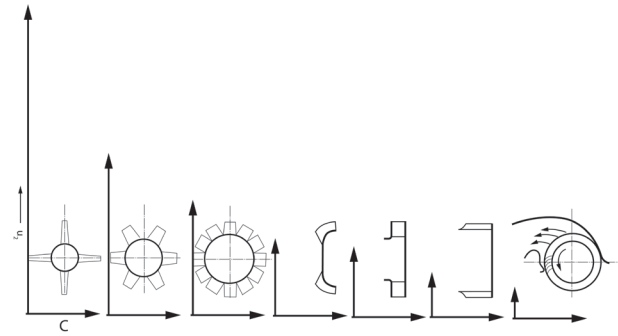

Fig. 6.29. Different blade tip speeds at the same discharge speeds for different types of impeller

As it was said above fan aerodynamics depends on conditions on the inlet and outlet. But, for example, even when there is a straight duct on the outlet of the fan, the aerodynamics of a fan can slightly differ from the case when there is no duct on the outlet. That is why in all the standards which are describing fan testings, several test facilities are presented. It is recommended to test fan in conditions, which are closer to its future installation conditions (fig 6.30).

Installation types of fans
gem. ISO 5801 and DIN 24163 T1

Mounting A
 $\Delta p_t = \Delta p_s + p_{d2}$

$p_{d2} = p/2 \cdot (V/F_2)^2$

$F_1 = \pi/4 \cdot DN^2$
 $F_2 = \pi/4 \cdot (DN^2 - HuB^2)$

Mounting B
 $\Delta p_t = \Delta p_s + p_{d2}$

$p_{d2} = p/2 \cdot (V/F_2)^2$

Mounting C
 $\Delta p_t = \Delta p_s + p_{d2} - p_{d1}$

$p_{d1} = p/2 \cdot (V/F_1)^2$
 $p_{d2} = p/2 \cdot (V/F_2)^2$

Mounting D
 $\Delta p_t = \Delta p_s + p_{d2} - p_{d1}$
 $\Delta p_t = \Delta p_s$
 $p_{d2} - p_{d1} = 0$

Fig. 6.30. Overview of installation types

Types of installation

According to ISO 5801 and DIN EN ISO 5801 there are four installation types for fans, which are defined as follows:

- Installation type A: free intake / free discharge
- Installation type B: free intake / duct on discharge side
- Installation type C: duct on intake side / free discharge
- Installation type D: duct on intake and discharge side

6.6 Parallel connection of fans

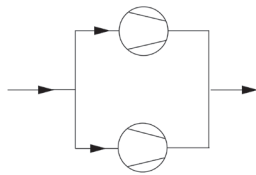

A parallel installation is when two or more fans are working next to each other between a common suction and pressure line. Several fans removing air from one room are also almost working in parallel.

Parallel installation is used when higher airflows are needed, or to have different airflow (depending on the season) or for effective regulation of airflow.

The following applies for parallel installation: at the same pressure, the airflows are added.

An example of a parallel operation of two permanently connected fans is the dual inlet radial fan. Fans which can be operated independently of each other are also connected in parallel. This can be useful from a control perspective because the airflow can be increased or decreased by switching a fan on or off. In practice, while the first fan is running the second fan should be started up with a closed throttle flap, and then join the system by opening the throttle device.

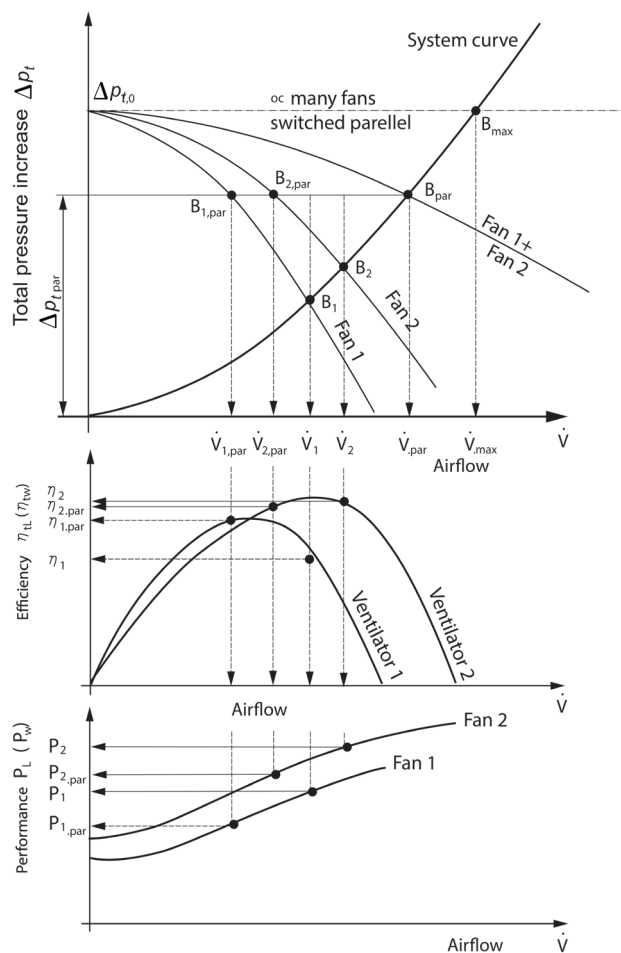

Fig. 6.31. Characteristic for the parallel connection of two fans

This, however, can be problematic for axial fans because here it is necessary to go through the stall range (fig. 6.32). A bypass connection would also be an alternative here.

However, the relationships become more complicated for the parallel installation of similar fans whose characteristics have a definite apex and/or turning point.

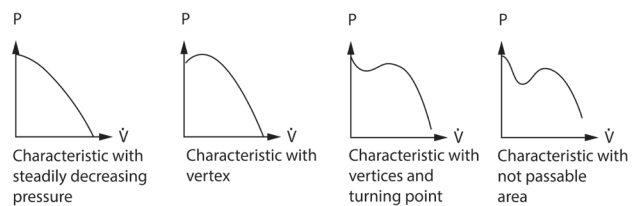

Fig. 6.32. Different distinctive forms of characteristic curves

Fans connected in parallel will only work together with no problems across the whole operating range if they have the same zero output pressure $\Delta p_{t,0}$ and the curves are stable (fig. 6.31).

If fans have different zero output pressure $\Delta p_{t,0}$ (fig. 6.33): when the smaller pressure $\Delta p_{t,0}$ is exceeded – i.e. the airflow falls below V_{min} – because the system is throttled – the system characteristic shifts to the left and there are backflow from the “stronger” fan 2 through the “weaker” fan 1.

Even before point B_{min} is reached, strong pulsations and airflow fluctuations occur which can also result in high mechanical loading on the fan – especially due to vibrations – which may lead to damage in certain circumstances.

Fans with unstable characteristics which have an apex and turning point, that is especially axial fans and radial fans with forward curved blades, can also only be operated in parallel within a limited range of system characteristics, since when the zero output pressure $\Delta p_{t,0}$ is exceeded – that is the airflow falls below the minimum airflow V_{min} – strong pulsations and backflows occur and/or the connection of standing fans to equipment already running would not even be possible because the start-up pressure is too low.

The same applies to the parallel connection of fans with unstable characteristics for dissimilar apex pressures (fig. 6.34), which despite the same zero output pressures only have a limited operating range, because when the pressure at the apex of the flatter throttle curve is exceeded it would cause a backflow – combined with strong pulsations.

It can be said that fans connected in parallel will only work together without problems if the individual operating points on the specified system characteristic lie in the stable range of the individual fan curves.

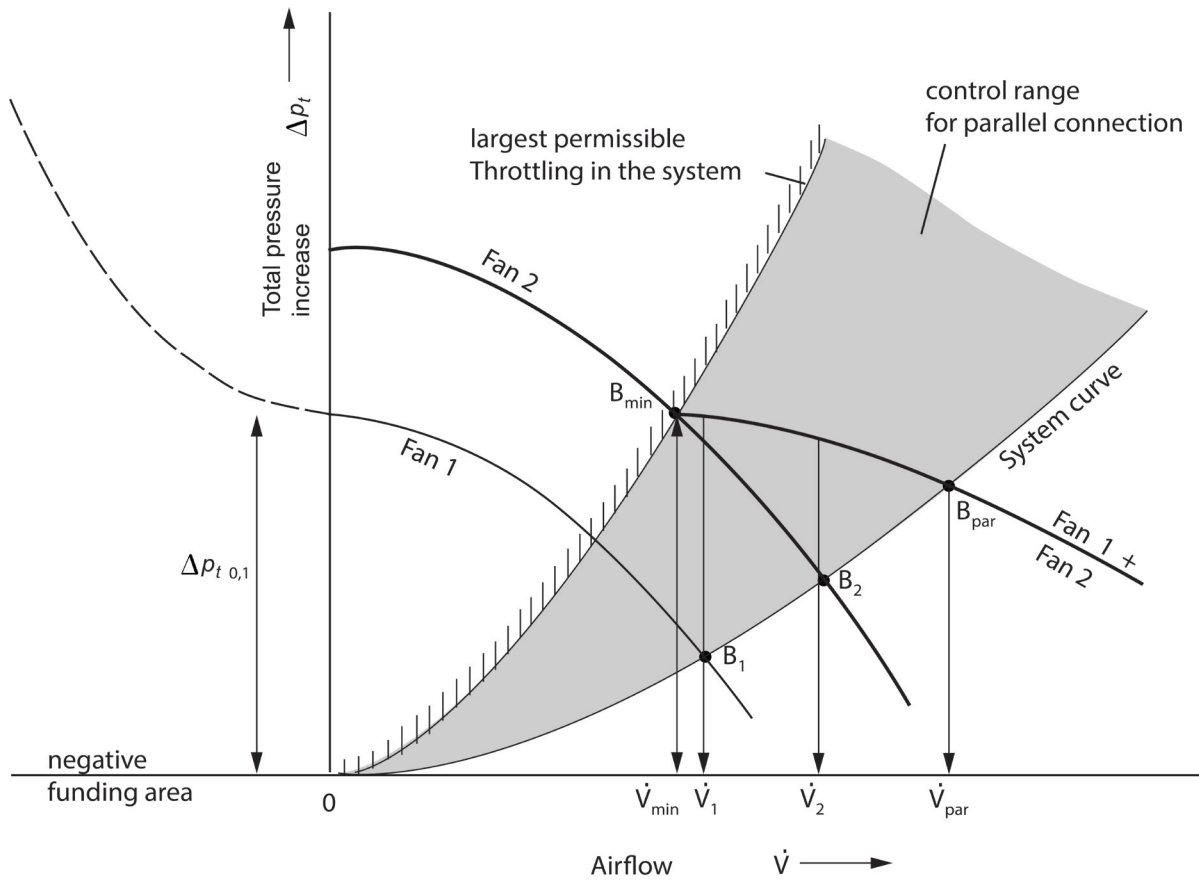

Fig. 6.33. Parallel work of two fans with different pressure at zero airflow

! With the diverse range of combinations and operating options for all the different fans, the system builder / operator and the fan manufacturer should carefully clarify the design together very early in the project because subsequent revisions and changes are only possible to a limited extent and are very expensive!

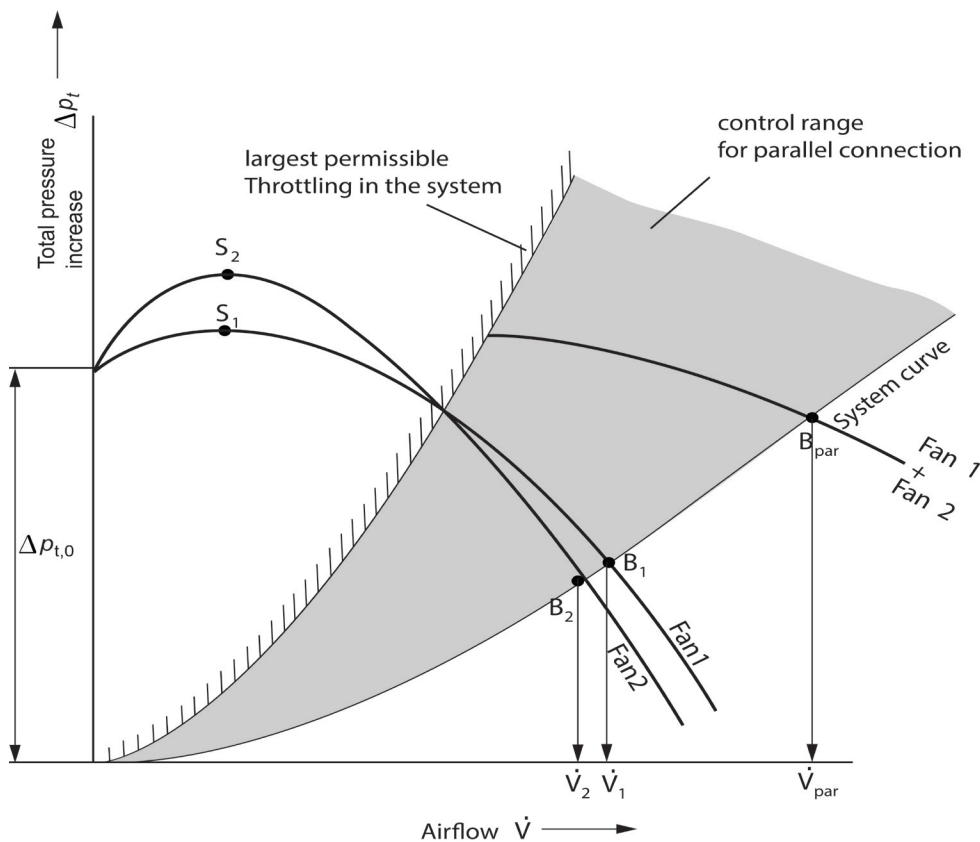
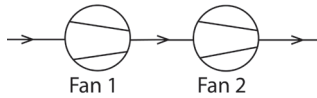

Fig. 6.34. Parallel work of two fans with different apex pressures

6.7 Series connection of fans



Series installation is when two or more similar or dissimilar fans are connected behind each other and work on a common duct system.

Series installation is usually used instead of the use of bigger size fan when higher pressure is needed.

The following applies for series installation:

The pressures are added for the respectively corresponding airflows (fig. 6.35).

- i Note:** In practice, pressures are not just added, because the frictional losses between the fan and the non-optimised flow before the second stage (second fan) prevent this. Even for two identical axial fans with outlet guide vanes and an ideal design when two fans are connected immediately behind each other – a pressure increase of approximately 1,6 to 1,9 times that for a single fan can be achieved.

If two identical fans are working instead of one on the same duct system, the airflow can be increased as shown on fig. 6.36.

If two, not identical fans are used in a series, airflow can be increased or decreased, depending on the correctness of the choice of an additional fan (fig. 6.37).

For example, we have basic fan 2 and we want to increase the airflow with the use of the additional fan 1. If we have system curve 1, then fan 2 alone was working at working point A with airflow V_A and after adding the additional fan 1, working point moved to B and airflow $V_B > V_A$ was achieved.

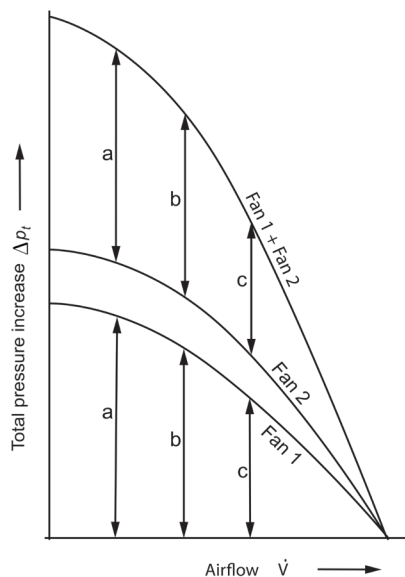

Fig. 6.35. Installing fans in series

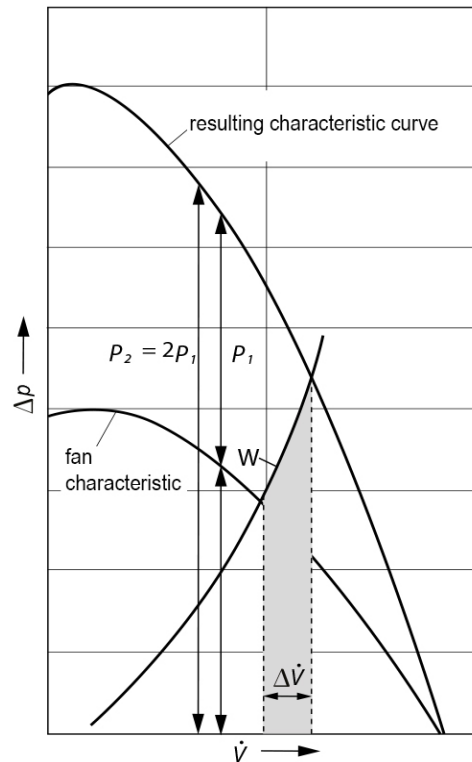

Fig. 6.36. Work of two identical fans in a series

On contrary if we have system curve 2, then fan 2 alone was working at working point A' with airflow $V_{A'}$ and after adding the additional fan 1, working point moved to B' and airflow $V_{B'} < V_{A'}$ was achieved.

And in addition, fan 1 absorbs power even when the airflow is lower.

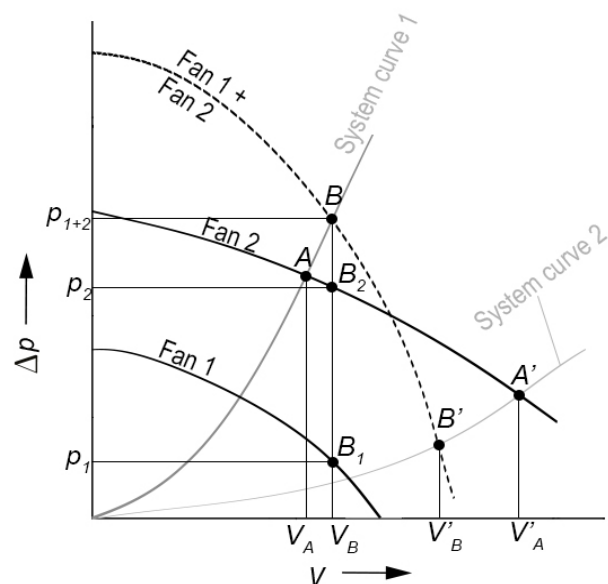

Fig. 6.37. Work of two different fans in a series

6.8 Fan in the system (vibrations)

Vibrations of the fan can appear because of very different reasons, the main causes of the fan vibrations are shown on fig. 6.38.

Although every produced fan has low levels of vibrations (fig. 6.39), vibration levels can change if the ducts are connected directly to the fan.

Types of machine damage on ventilators

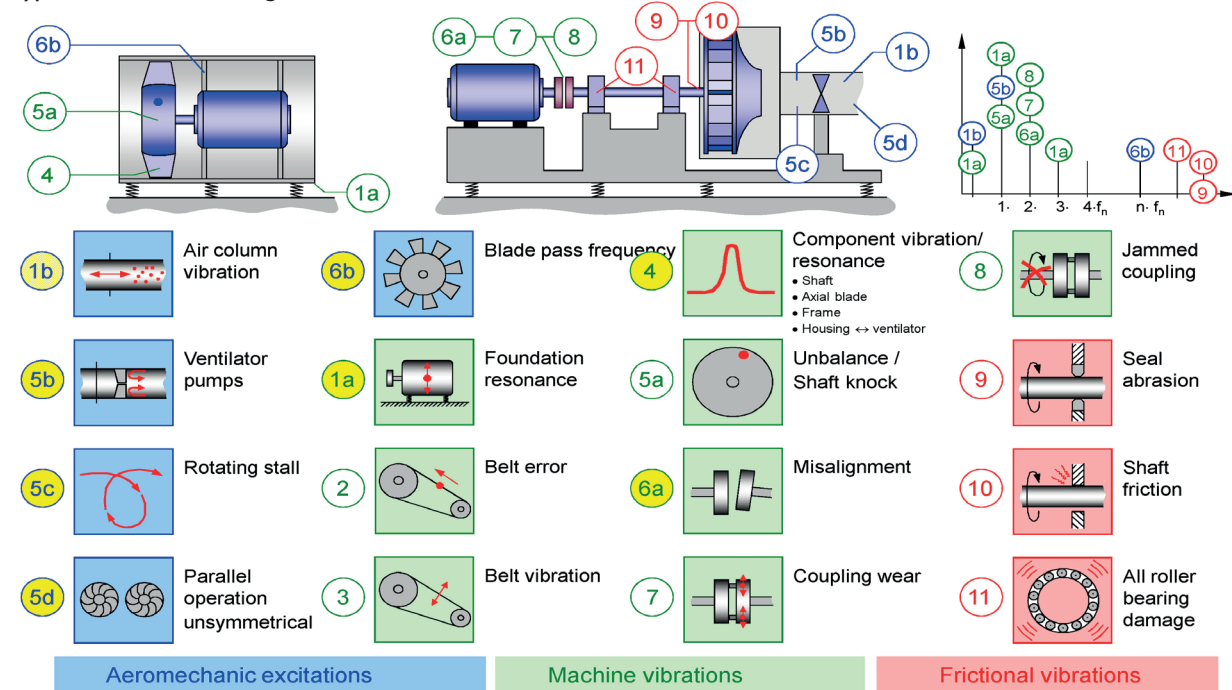

Fig. 6.38. Sources of vibrations

Operating states of machines

for example ISO 10816-3 limits for vibration speed

								v.r.m.s. in mm/s	v.r.m.s. in inch/s	Vibration speed 10 000 Hz to 630 1/min (2 000 Hz to 120 1/min)
								11	0,433	
								7,1	0,280	
								4,5	0,177	
								3,5	0,138	
								2,8	0,110	
								2,3	0,091	
								1,4	0,055	
								0,71	0,028	
rigid	soft	rigid	soft	rigid	soft	rigid	soft	Fundament		
Pumps >15kW radial, axial, diagonal				middlesize machine 15 kW < P < 300 kW		largesize machine 300 kW < P < 50 MW		Machine type		
Direct connection		Intermediate shaft/Belt drive		Motors 160mm < H < 315mm		Motors 315mm < H		Group		
Group 4		Group 3		Group 2		Group 1				

Legend:
 newly produced
 unlimited long-term operation
 short time operation
 vibrations which can cause damage

Fig. 6.39. Vibration speed of machines

To guarantee a disruption-free operation of fans in the system of ducts, a range of rules and regulations must be used to when installing fans (axial, radial or diagonal fans). Fans must be decoupled from the duct system and insulated from the structure so that the fan can vibrate freely.

- Decoupling

To decouple noise and/or vibration and to compensate for expansion, elastic expansion joints (fig. 6.40-6.42) are placed between the fans and the duct system. A

wide range of materials is used for this, which meet all kinds of requirements – whereby the tightness should comply with DIN EN 1507 and VDI 3803.

- The following versions are available:
 - Ventilation and air conditioning version
 - Temperature-dependent version
 - Fire protection version
 - ATEX – version
 - Special versions

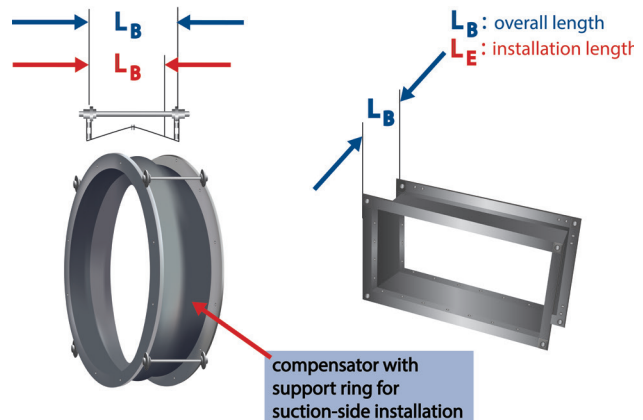

Fig. 6.40. Expansion joints (example: tubular and rectangular)

To avoid placing an additional load on the system characteristic, these should be placed on the suction side of the fan, with a supporting ring or guide plates.

Care must be taken that the difference between the installation length L_E and actual length L_B of the expansion joint should not exceed 10 – max.15 [mm].

$$L_E = L_B - 10(15) \quad [\text{mm}]$$

L_E : installation length [mm]
 L_B : actual length [mm]

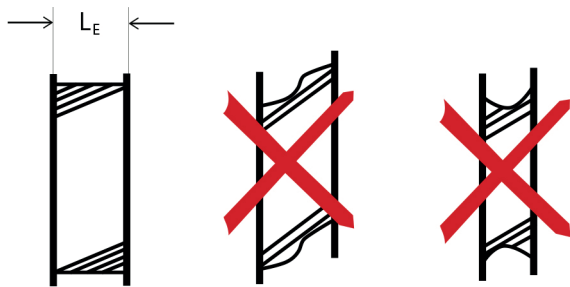

Fig. 6.41. Expansion joint installation

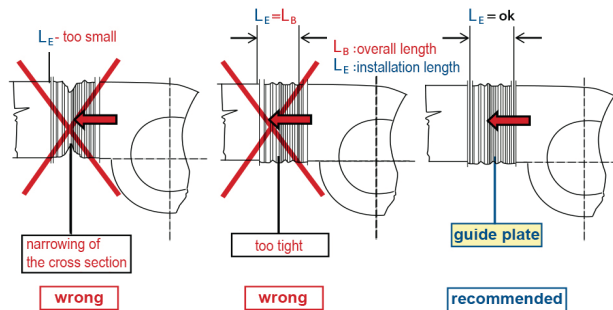

Fig. 6.42. Radial fan, expansion joint installation

Damping vibrations

Vibrations are created by every machine (fan) with rotating or oscillating unbalanced mass. If the fan is rigidly connected to the base, this will cause transition of the vibration.

These vibrations often create unwelcome noise, even in faraway rooms.

This is referred to as structure-borne(mechanical) noise. To dampen the transmission of structure-borne noise and vibration forces, vibration dampers are installed underneath fans. These should be adjusted to the resonance frequencies and mass of the entire fan or machine.

Vibration dampers must be located underneath the fan unit in such a way that there is an even loading/damper compression. It is not sufficient just to have the load distributed symmetrically around the overall centre of gravity of the system at rest – the opposing force of the fan's pressure increase must be taken into account. The centre of gravity can be determined using two procedures:

- By balancing the fan on a roller
- Using a CAD computation process (total centre of gravity across all individual centres of gravity)
- The following vibration dampers are used in ventilation and air conditioning (fig. 6.43):

- For small and medium-sized loads:
Rubber – and/or spring vibration dampers
- For large loads:
Block elements, hydraulic vibration dampers
- For loads covering large areas:
Polyurethane (PUR) elements or strips

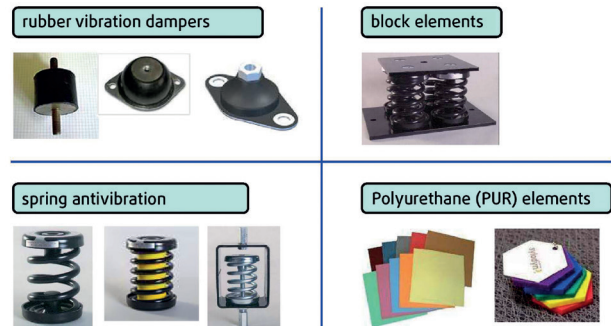

Fig. 6.43. Vibration damper

The function of a vibration damper (steel spring) (fig. 6.44)

The steel spring is an elastic, flexible design element which permits large deformations. It absorbs the work of deformation, stores this in the form of potential energy and releases this once more when it is unloaded, apart from a small proportion which is converted into heat.

Hooke's law
The draught is proportional to the loading force.

$$c = F/s$$

c = Spring constant [N/mm)

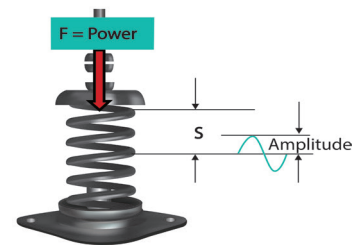

Fig. 6.44. Function of a spring vibration damper

Proper installation of vibration dampers for several cases should take place as shown in the following figures (fig. 6.45-6.50).

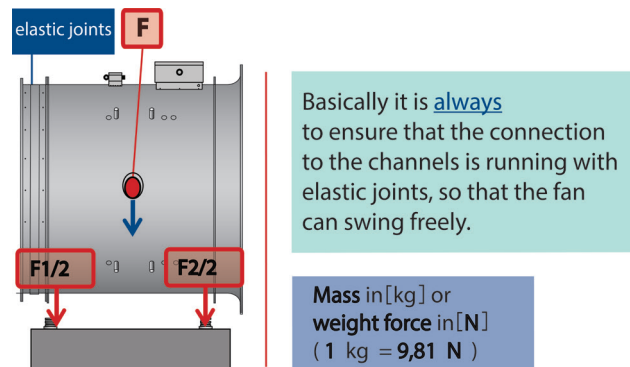

Fig. 6.45. Even load distribution (horizontal)

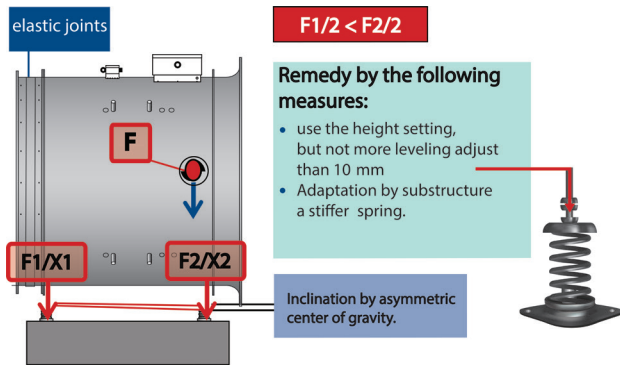

Fig. 6.46. Uneven load distribution (horizontal)

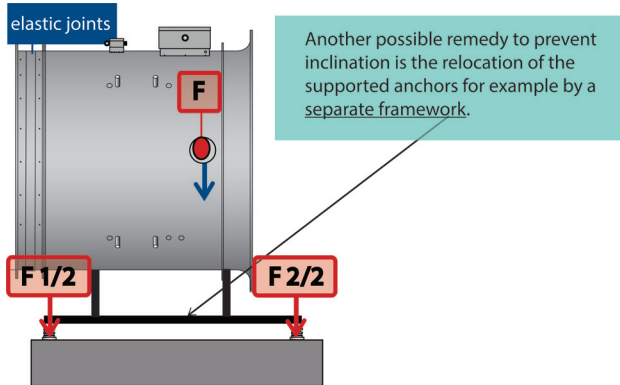

Fig. 6.47. Uneven load distribution with base frame (horizontal)

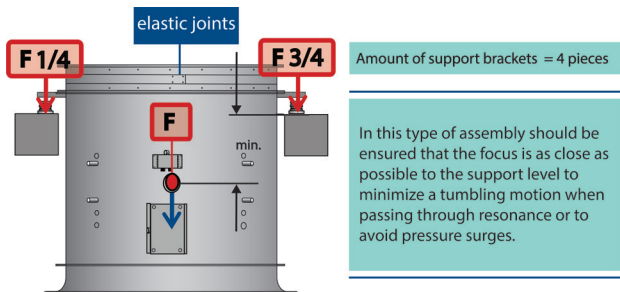

Fig. 6.48. Even load distribution (vertical)

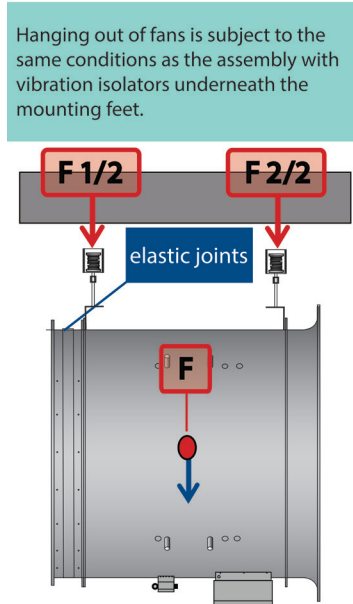

Fig. 6.49. Even load distribution (horizontal – under tensile load)

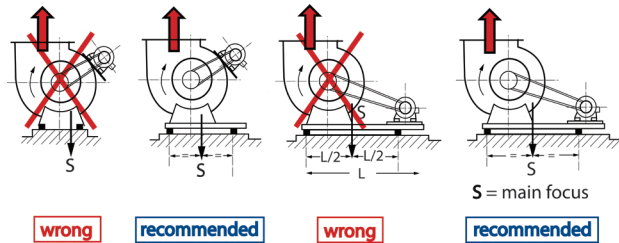

Fig. 6.50. Radial fan, vibration dampers

6.9 Pressure measurement in the system

To deal with the measurements of fan parameters in the system ISO 5802 can be used.

Usually, the distribution of velocities in the plane of measurements should be checked in advance to be sure that the conditions in this plane are appropriate (see ISO 5802).

It is normal to treat pressures as absolute values in ventilation engineering, vis-à-vis the atmospheric pressure p_a which is taken as the reference zero points. Therefore there are also negative pressures, e.g. on the suction side of the fan. The total pressure difference of a fan is the difference of the total pressures between the entry and exit, i.e. the sum of all static pressure differences Δp_s and the dynamic pressure difference Δp_d (each measured as the average values for the air velocity across the entry and exit surfaces of the fan).

Index 1 =	Suction side of the fan
Index 2 =	Pressure side of the fan

eq. 6.9-01

$$\Delta p_t = p_{t2} - p_{t1} = p_{s2} + p_{d2} - (p_{s1} + p_{d1})$$

$$\Delta p_t = p_{s2} - p_{s1} + p_{d2} - p_{d1}$$

$$\Delta p_t = \Delta p_s + \Delta p_d$$

In practice, a differential manometer is used. To determine the static pressure p_s , the differential manometer is connected with circumferential duct lines to static pressure taps in the duct (fig. 6.51). To measure dynamic pressure p_d Pitot-static tube is used (it also measures static and total pressure). Total pressure can be measured directly with a total pressure tube.

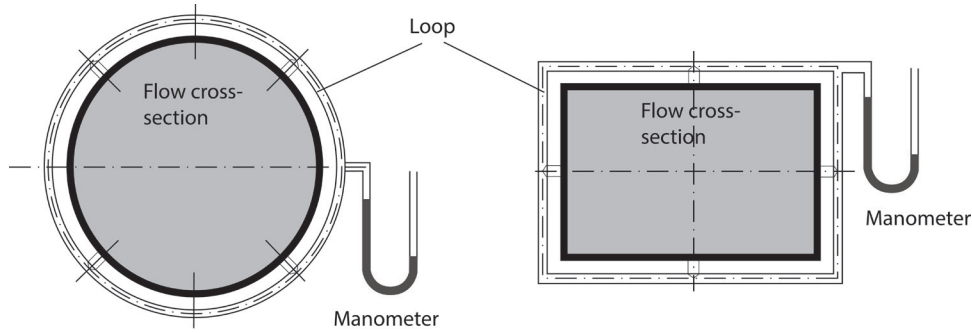

Fig. 6.51. Closed circumferential ductlines on the measurement points of a system

Position of measurement points in a unit

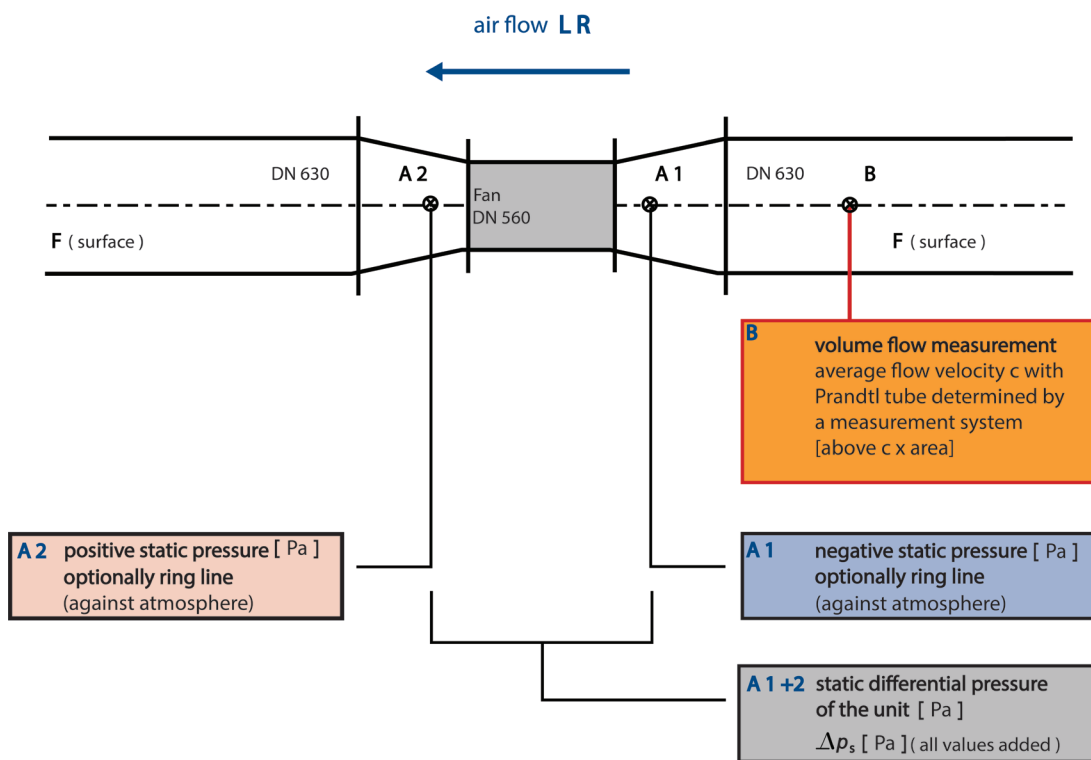

Fig. 6.52. Positioning the measurement points in the system

When measuring static pressure, care must be taken that the measurement points A1 + A2 are located as close as possible to the fan. In this way, all static pressures of the system are recorded.

6.10 Airflow measurement in the system

Measuring the airflow in a ventilation system is significantly more complex and difficult than the pressure measurement. It is almost impossible to make an aim assessment of measured values without basic knowledge of aerodynamic processes. It is often very difficult to find the correct point in a system where a reliable average flow velocity can be measured using the grid method. These indirect measurement methods are carried out using a Pitot-static tube and are subject to specified rules determined in ISO 5802, ISO 3966 and VDI 2640 (fig. 6.53).

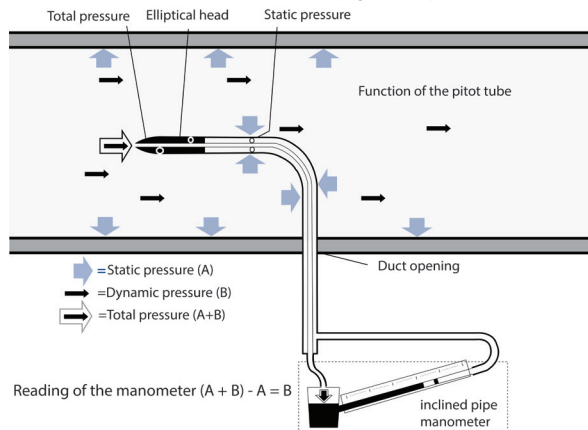

Fig. 6.53. Function of the pitot tube

Determining the average flow velocity using the grid method (fig. 6.54-6.55):

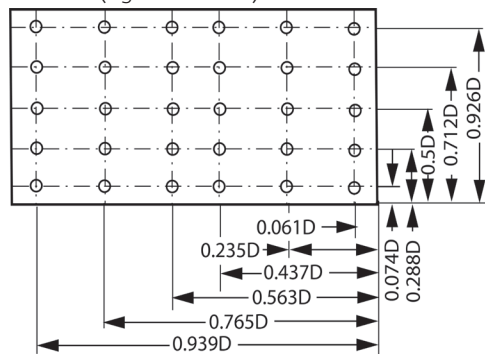

Fig. 6.54. Defined measurement points in a rectangular duct

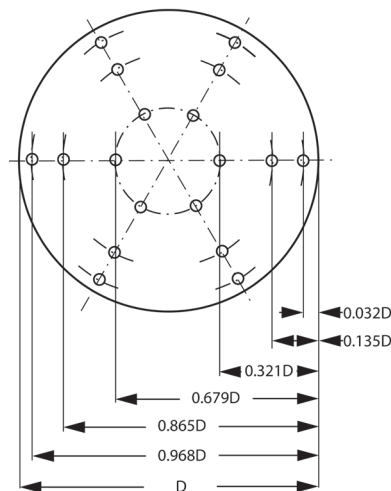

Fig. 6.55. Defined measurement points in a round duct

If these rules are not adhered to, false measurements will result. One of the most important rules is:

- i "If only one value deviates over 25 [%] from the average value, this entire measurement cannot be used to determine the airflow!"

The following applies for determining the airflow using the average velocity:

$$V = c \cdot F \quad [m^3/s] \quad F = \text{cross-sectional area} \quad [m^2] \text{ at measurement point}$$

$$c = \text{Average flow velocity} \quad [m/s]$$

- i **Warning.** Do not take measurements in front of or behind bends or curves, branches, transition pieces and other installation components. These components give the system flow profiles which can lead to erroneous measurement results.

The following examples show different flow profiles which may occur in the duct (fig. 6.56). The average flow velocity can determine the dynamic pressure p_{dyn} according to the following formula:

$$p_{dyn} = \rho/2 \cdot c^2 \quad [Pa] \quad \rho = \text{air density} \quad [kg/m^3]$$

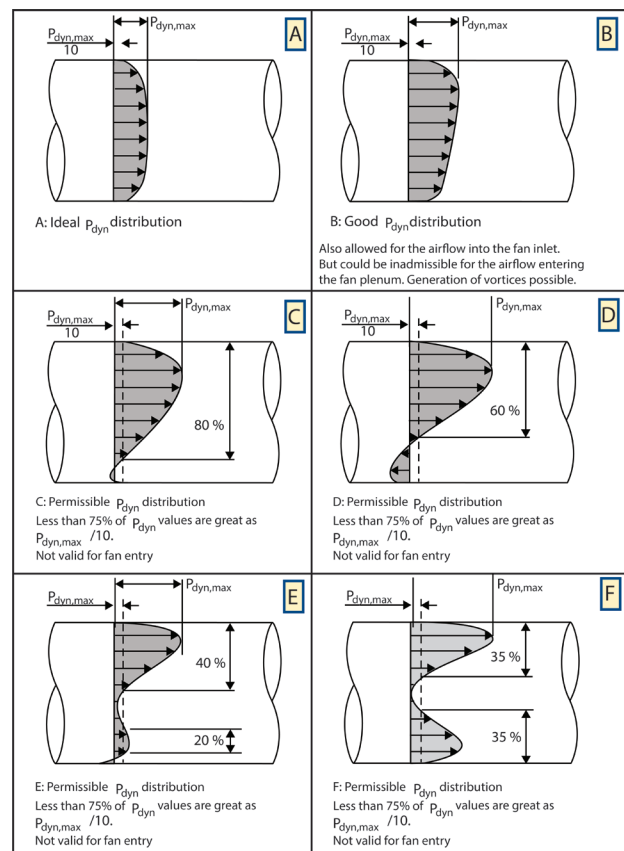

Fig. 6.56. Typical flow profiles in ducts

Flow profile A- B (p_{dyn} – distribution)

for determining the airflow – possible
for fan inlet – permissible

Flow profile C- F (p_{dyn} – distribution)

for determining the airflow – not permissible
for fan inlet – not permissible

Another example of how, even at small flow velocities, a relatively large turbulence zone can form in a duct branch. As the velocity of the air current increases, this area enlarges considerably (fig. 6.57-6.59).

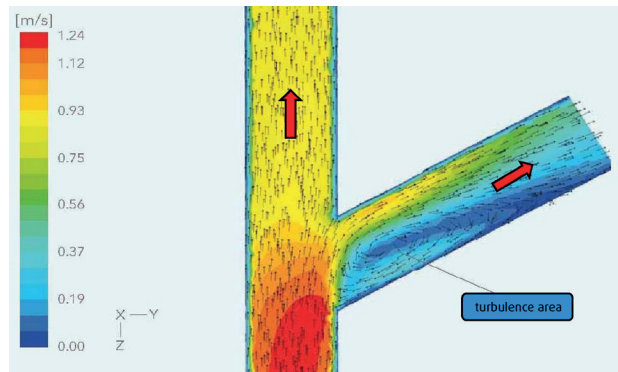

Fig. 6.57. Flow diagram in a branched duct

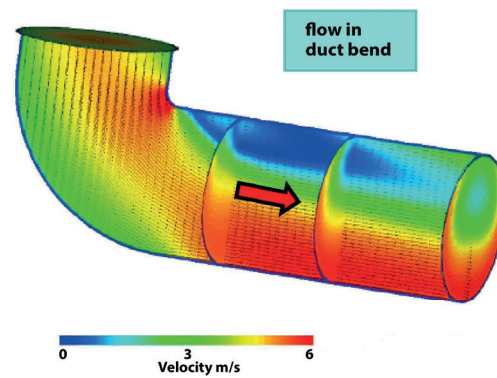

Fig. 6.58. Flow diagram – bend in duct

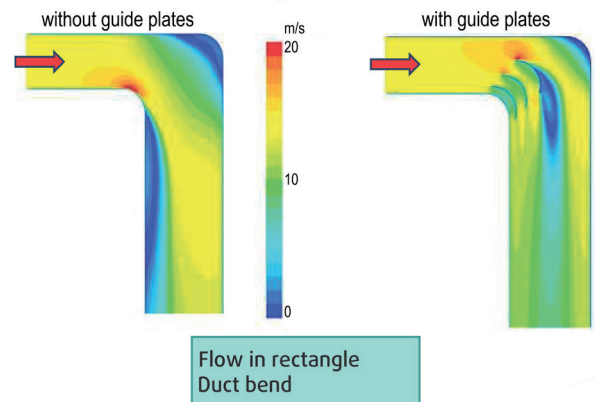

Fig. 6.59. Flow diagram – bend in duct with / without guide plate

6.11 Influence of medium density

Influence of the density of the transported medium on the performance data of the fans

The temperature has a direct effect on the density of the medium being transported, on the delivered mass flow m and therefore also on the pressure increase of the fan Δp_t .

The delivered airflow V remains unaffected!

eq. 3.3-01 $V_1 = V_2 = \text{constant}$

Index	20	[°C]
1:		

eq. 3.3-02 $m_1 = V_1 \cdot \rho_1$

Index	XX	[°C]
2:		

$m_2 = V_2 \cdot \rho_2$

If the fan is for a ventilation system where slight deviations from the normal state of the air (density $\rho = 1,204$ [kg/m³] – corresponding to $t = 20$ [°C] and a barometer reading of $p_a = 1013$ [mbar]) can be ignored, the fan should be selected directly according to the characteristic or selection tables.

eq. 3.1.1-01 $\rho = p_1 / (R \cdot (T \pm t_1))$

$p_1 = p_a - p_s$

p_s : static pressure on the fan [Pa]

p_a : atmospheric pressure = 101300 [Pa]

Because there is an underpressure on the suction side for every ventilation system – except free-intake fans, this must also be taken into account when determining the density.

If it is not possible to ignore this (e.g. for higher air temperatures or system installation at an altitude $H_a = XXX$ [m] above sea level), the effectively required pressure Δp_t must be converted for the system.

eq. 3.1.2-04 $p_H = p_a \cdot e^{(-H_a/7990)}$ [Pa]

The pressure $\Delta p_t(20$ [°C]) = Δp_{t1} needs to be determined, which the fan must generate when delivering air at a “normal state” so it achieves the required effective pressure $\Delta p_t(XX^\circ) = \Delta p_{t2}$ for the different density.

eq. 3.1.2-02 $\frac{\Delta p_{t1}/\Delta p_{t2}}{\Delta p_{t2}} = \frac{\rho_1/\rho_2}{\Delta p_{t1} \cdot \rho_2/\rho_1} = \frac{T_2/T_1}{\Delta p_{t1} \cdot T_1/T_2}$

Example 1 (fig. 6.60):

A fan is to deliver air at 120 [°C] according to a specified characteristic. If the required characteristic were used (Fan 20 [°C]), under operating conditions ($t_1 = 120$ [°C], $\rho_1 = 0,898$ [kg/m³]) the pressure generated would be 25 [%] lower than planned.

$T_0/T_1 = (273+20)/(273+120) = 0,898/1,204$
 $= 0,75$ (= Characteristic 1/ AKL 1)

In order for the required characteristic / operating point to be 100% achieved, a characteristic must be selected (from a catalogue) which lies above the required pressure values (= Characteristic 2 / AKL 2) by a factor of $1/0,75 = 1,33$.

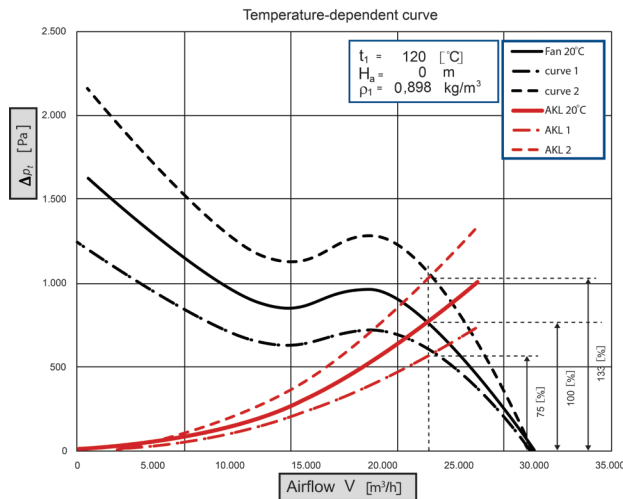

Fig. 6.60. Characteristic for air at 120 [°C]

Example 2 (fig. 6.61):

A fan is to be operated at an altitude of $H_a = 1\,250$ [m]. The delivery medium is air at $t_1 = 20$ [°C], the characteristic is specified with Fan 20 [°C] (at sea level). Under the gas equation [3.1.1] and the altitude formula [3.1.2] the density at 1 250 [m] and 20 [°C] is $\rho_1 = 1,030$ [kg/m³]. Therefore, the air density at the operating conditions is reduced by the factor:

$$\begin{aligned} b_1/b_0 &= \rho_1/\rho_0 = 1,030/1,204 \\ &= 0,86 \quad (= \text{Characteristic 1 / AKL 1}) \end{aligned}$$

In order for the required pressure increase to be achieved, a fan must be selected (from a catalogue) which can generate a pressure higher by the factor $1/0,86 = 1,17$ (= Characteristic 2 / AKL 2).

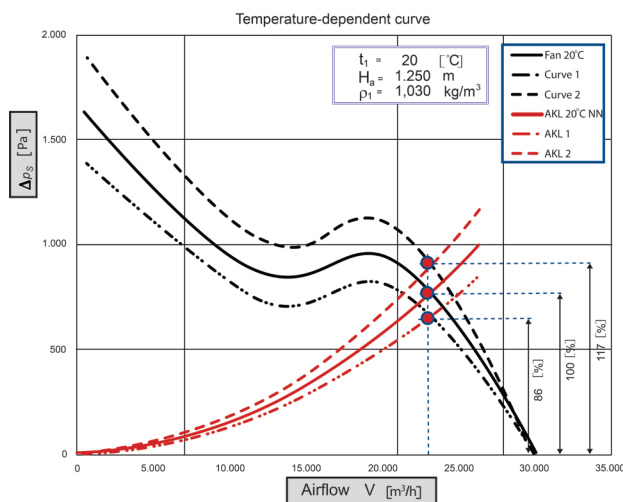

Fig. 6.61. Characteristic curve at 20 [°C] and 1 250 [m] altitude

The power to the shaft of a fan also behaves in a similar way to the behaviour of pressure when the temperature changes, according to the relationship:

$$\text{eq. 6.2.1-01} \quad P_w = (V \cdot \Delta p_s) / \eta \quad [W]$$

$$\begin{aligned} \text{eq. 3.1.2-03} \quad P_{w1} / P_{w2} &= \rho_1 / \rho_2 = T_2 / T_1 \\ P_{w2} &= P_{w1} \cdot \rho_2 / \rho_1 = P_{w1} \cdot T_1 / T_2 \end{aligned}$$

The standard volume is the volume of gas in its normal state. According to DIN 1343, a gas is in a normal state at a temperature of 0 [°C] and a pressure of 101 300 [Pa] (= 0 [m] altitude = sea level).

The density at 0 [°C] and atmospheric pressure is $\rho = 1,293$ [kg/m³]. The term “standard cubic metre” often appears in requests for tenders. A “standard cubic metre” is, therefore, one m³ of air at 0 [°C] and 0 [m] altitude (sea level). If air at t_1 [°C] and pressure p_1 [Pa] has the volume V_1 , the standard volume V_n can be calculated according to the equation:

$$\text{eq. 6.1.1-01} \quad V_n = V_1 \cdot p_1 / p_s \cdot T / (T + t_1)$$

Example 3:

How many standard cubic metres has a volume of $V_1 = 40\,000$ [m³] at a temperature t_1 of 20 [°C] at sea level?

$$\begin{aligned} V_n &= 40\,000 \cdot 101\,300 / 101\,300 \cdot 273 / (273 + 20) \\ V_n &= 37\,270 \quad [m^3] \end{aligned}$$

Example 4:

For a ventilation system, a request for tenders requires $V_n = 40\,000$ [m³] standard cubic metres. The underpressure at the fan inlet is 450 [Pa]. The required airflow V_1 is to be measured on the pressure side at 750 [Pa] and a temperature of 40 [°C].

Problem 1:

What airflow V_1 must the fan be designed (at the characteristic condition $\rho = 1,204$ [kg/m³])?

Problem 2:

What airflow V_1 is required at the measurement point behind the fan to confirm the delivery of $V_n = 40\,000$ [m³/h] standard cubic metres per hour?

$$V_1 = V_n \cdot p_a \cdot (T + t_1) / (T \cdot (p_a - p_s))$$

$$\begin{aligned} \text{Solution 1: } V_1 &= 40\,000 \cdot 101\,300 \cdot (273 + 20) / (273 \cdot (101\,300 - 450)) \\ V_1 &= 43\,222 \quad [m^3/h] \end{aligned}$$

$$\begin{aligned} \text{Solution 2: } V_1 &= 40\,000 \cdot 101\,300 \cdot (273 + 40) / (273 \cdot (101\,300 + 750)) \\ V_1 &= 45\,586 \quad [m^3/h] \end{aligned}$$

$$\begin{aligned} V_n &= 40\,000 \quad [m^3/h] \\ t_1 &= 20 \quad [^\circ C] \\ t_2 &= 40 \quad [^\circ C] \\ p_{s1} &= -450 \quad [Pa] \\ p_{s2} &= 750 \quad [Pa] \end{aligned}$$

7. Controlling fans

The operating behaviour of a fan depends on the type, size, speed and their interaction with the system i.e. it adjusts to the corresponding pressure for a certain airflow. The power requirement, efficiency and noise emission also depend on the airflow. If the airflow changes and/or the system pressure changes, the fan must be adjusted to the new data, by either open loop control or closed-loop control. There is a wide range of instruments available

for performing this adjustment/control, with different efficiencies and costs – whereby the most cost-effective solution for the particular application should be selected (see fig. 7.1). The normal operating data of a fan in most times is very important for disturbance-free, economical operation – regarding the mechanical loading of the fan due to particular forces, vibrations, wear etc., depending on the respective operating point.

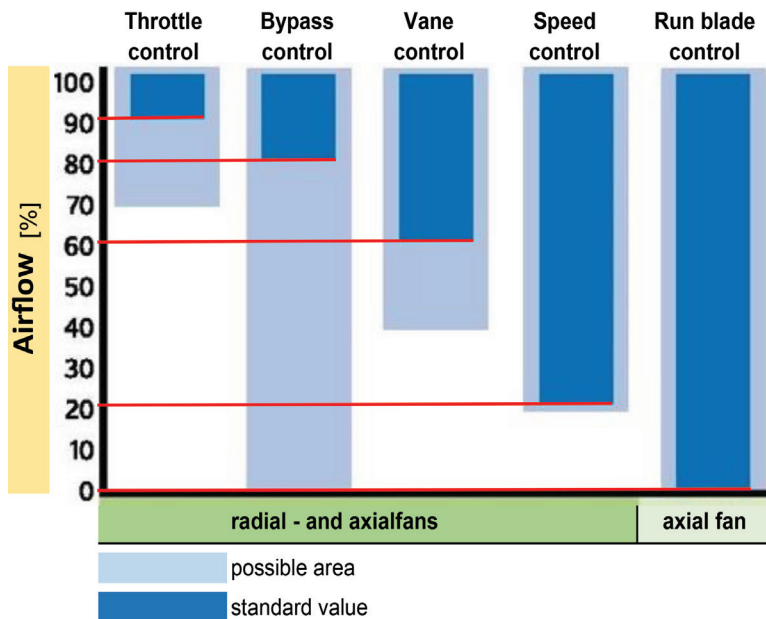

Fig.7.1. Control ranges

7.1 Remarks, general

Essentially, the following criteria are important for the selection of the control system:

- Control range
- Control accuracy
- Energy-saving
- Operational safety
- Investment costs
- Maintenance costs
- Noise emission
- Economy

The most common control systems are described below to help you make the right selection for a particular case.

The control systems are:

- Throttle control
- Speed control
- Blade control
- Vane control
- Bypass control

The following figure shows the achievable control ranges for the different control systems:

The control target is the desired change to the operating point of a system, whereas the control path describes the path on which the operating point moves during the control operation.

- Control path 1 (see fig. 7.2)
constant pressure at variable volume
- Control path 2 (see fig. 7.2)
constant volume at variable pressure
- Control path 3 (see fig. 7.2)
Control path along with the system characteristic
- Control path 4 (see fig. 7.2)
Control path at constant system pressure

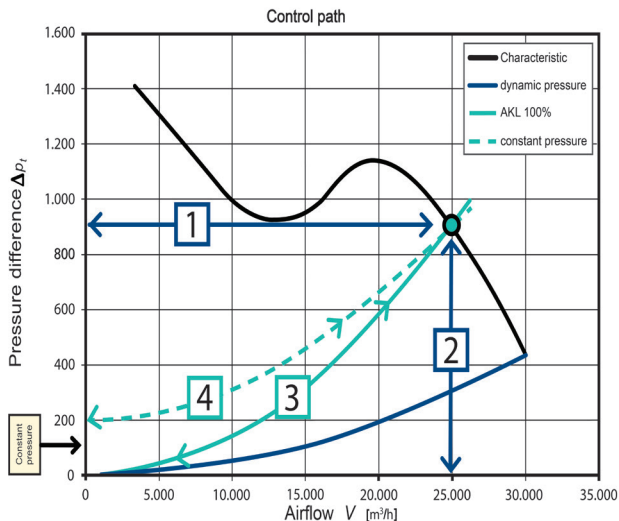

Fig. 7.2 Control paths

7.2 Throttle control

This control method is the cheapest and simplest way of changing the airflow (fig. 7.3). The system pressure can be reduced or increased using a throttle in the duct system. Increasing or reducing the pressure changes the system characteristic. It is clear that relatively large pressure increases can lead to comparatively small changes in the airflow.

This type of control is problematic for axial fans because when the operating point is offset to the left, it can quickly land in the stall range (unstable range of the fan characteristic). This mostly, but not only, affects fan characteristics which have an apex and/or turning point or characteristics with inaccessible regions. For cost reasons, throttle control is unsuited to larger airflows.

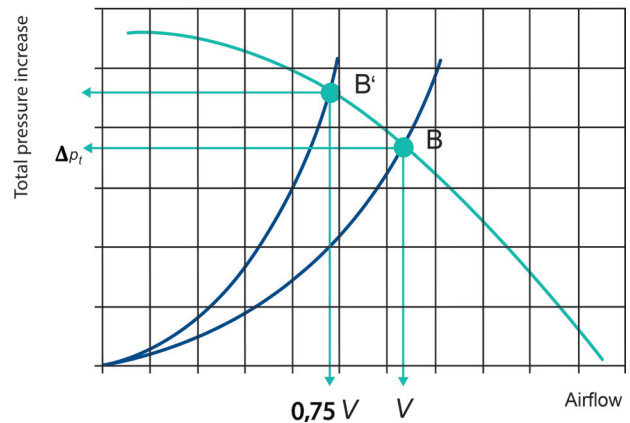

Fig. 7.3. Throttle control (diagram)

7.3 Speed control

- **Stepless speed control.** This type of control (no matter on what principle it functions) is – for the control demand along the system characteristic with the relation $p_t \sim n^2$ – the type of control where the fan can always work at the point of optimum efficiency (fig. 7.4). The performance curve approximately follows the relation $P_w \sim n^3$ and the airflow $V \sim n$.
 - The fan characteristic changes according to the laws of proportionality!

If the energy requirement along the conventional control paths is considered, speed control always has the lowest values. This means that speed control is the most economical control type.

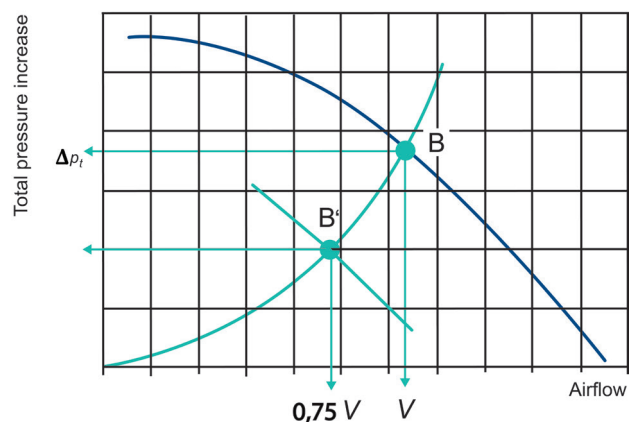

Fig. 7.4. Speed control (diagram)

The determination of the fan design point is dependent on the course of the control path. Depending on the control path, it is sensible and more cost-effective to situate the maximum operating point to the left or to the right of the optimum efficiency. Over the entire operating period, a ventilation system never works exclusively in the range of the maximum operating point.

Therefore, when selecting the fan, the range in which the control path will mostly be moving must be taken into account. The maximum fan efficiency should lie within this range.

Electronic phase-angle controllers and frequency converters can be used for speed control. Effective motor voltage is changed in all cases.

- Phase-angle controller

In a phase-angle controller, a variable three-phase voltage is generated using static electronic voltage controllers. This enables the speed of the cage motor to be controlled.

- Frequency converter

Using a frequency converter, the motor voltage is changed linearly with the frequency. The aim is to generate a certain constant torque across the entire frequency range for a certain slip.

There are two common types of converted systems:

- I - converter, with current controlled link
- V - converter, with voltage-controlled link

In the performance range up to 500 [kW] both systems cost more or less the same. Regarding power consumption, the V-converter is 60 – 100 [%] more economical in the upper-speed control range and the I-converter 30 – 60 [%] more economical in the lower speed control range.

- **Stepped speed control.** For certain control paths, there are a few other systems which can also be used for airflow control:

- Multi-stage motors (pole-changing motors)
- Step transformers
- Switching multiple fans connected in parallel on or off – or series connection

7.4 Blade control

For axial fans with adjustable blades, it is possible to control the airflow by changing the angle of the impeller blades (fig. 7.5).

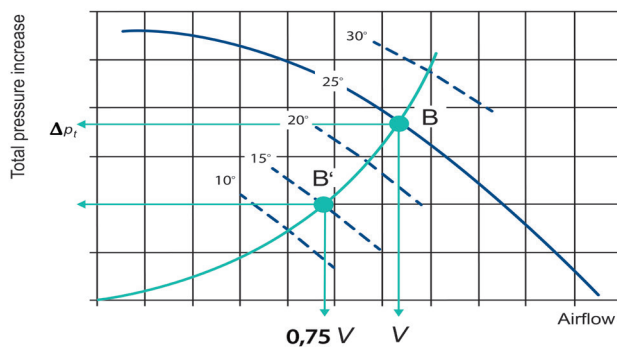

Fig. 7.5. Blade control (diagram)

For this to work, the axial fans need to have a continuous characteristic or system characteristic field, without a pumping limit and with a stable working range. Fans with these characteristics are very well suited to parallel operation.

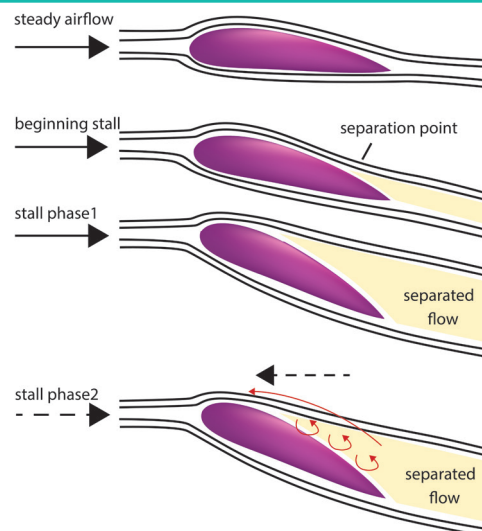

Fig. 7.6. STALL effect (figure)

However, often characteristics or system characteristic fields have unstable regions with a "stall edge" at which the flow stalls – so the fan starts to "pump". The flow through the impeller is partially blocked by separation zones in the blade's region tips and/or near the hub; the flow stalls (fig. 7.6, 7.7). This phenomenon is known as the STALL effect.

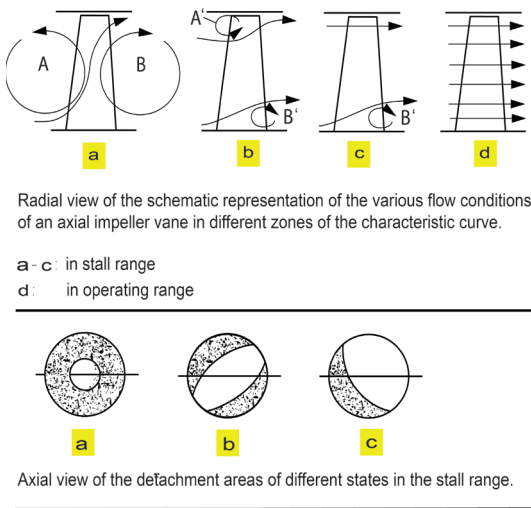
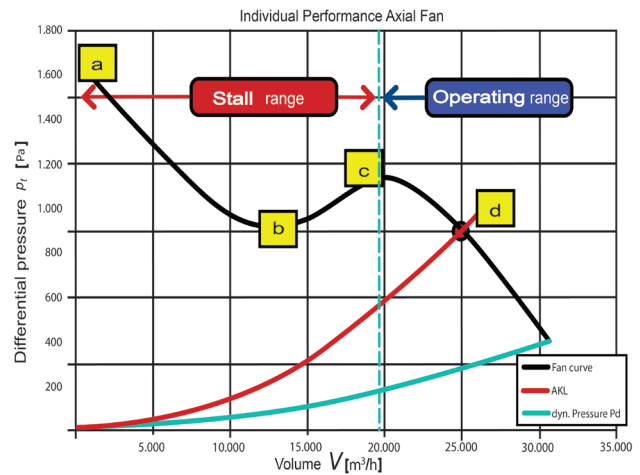

Fig. 7.7. STALL region in impeller (graph / diagram)



There is another phenomenon called "rotating stall". Here, the flow stalls within just one or several groups of blades. The flow between blades 2 – 5 is partially blocked by turbulence, so that the medium (partial flow) is forced between blades 1 / 2 and 5 / 6 (fig. 7.8). This results in considerable mechanical/vibrational loading of the impeller blades. The consequence is damage to or destruction of the impeller.

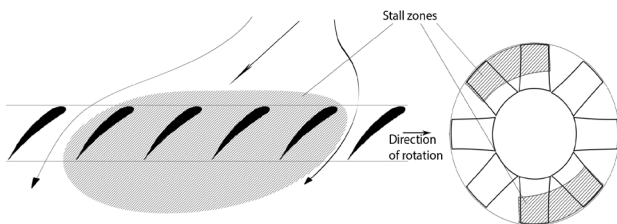

Fig. 7.8. "Rotating STALL" effect (figure)

To eliminate these effects and to make sure it is possible to safely adjust the blades, a stabilisation ring is integrated into the fan housing in front of the impeller (fig. 7.9). The flow across the entire surface of the impeller is therefore stable, independent of the selected operating point. The radial flow component resulting from strong throttling is stabilised and reoriented by a ring-shaped duct, which is in front of the impeller. The ring only functions when the fan enters the unstable range due to throttling.

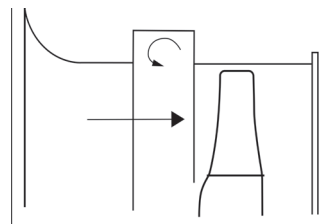

Fig. 7.9. Stabilising ring of an anti-stall design

7.5 Vane control

A vane controller is an air inlet component with infinitely adjustable blades controlled by a servomotor. A swirling flow is generated at the impeller inlet which changes the entry speed c_1 into the impeller.

Depending on the direction of the swirl, one refers to

- Co-rotating – in the same direction of rotation as the impeller =
+ c_1 ► reduction of the airflow
- Counter-rotating – in the opposite direction to the impeller direction of rotation =
- c_1 ► increase in the airflow

In practice, the theoretically airflow increase for counter-rotation has not been confirmed for radial fans, so here vane controllers are only designed with co-rotation. However, for axial fans, corresponding airflow increases are possible (fig. 7.10-7.11).

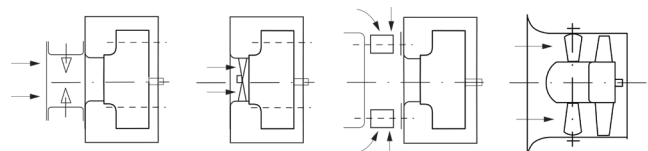

Fig. 7.10. Types of vane controllers (figure)



Fig. 7.11. Vane controller for axial fan (figure)

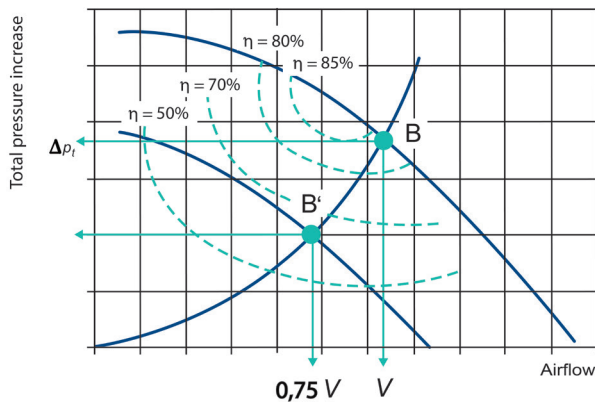

Fig. 7.12. Vane controller characteristic (diagram)

There is a new fan characteristic for each guide vane position of the vane controller, which lies below the characteristic when the vane controller is open (fig. 7.12).

- The angle of adjustment 0° open vane controller
- The angle of adjustment 90° closed vane controller

The strength of the swirl depends only on the respective position of the blades. Due to the swirl of the airflow entering the fan's impeller, the entire characteristics of the fan changes – such as the total pressure increase, the power requirement of the shaft, the efficiency and the noise emission.

- The difference between throttle control and vane control:
 - Throttle control
Change to the system characteristic / fan characteristic remains unchanged
 - Vane control
System characteristic remains unchanged / fan characteristic changes

Therefore the drive power is always below the throttle control and is thus more cost-effective for the same airflow.

The utilisation of the kinetic energy is only possible if the vane controller is located directly in front of the impeller. If this was just somewhere in the duct system, the kinetic energy could not be usefully converted.

- Suitable for vane control are :
 - Radial fans with backwards curving blades
 - Axial fans

To guarantee the most practical and sensitive control possible, the control path should not go beyond an 80° blade position. Depending on the design point and the control path, this position is reached at around 50 to 60 [%] of the maximum airflow.

Since there is almost no difference between the fan characteristic without a vane controller and with an installed, open vane controller, this is neglected in practice. The difference is around 1 – 3 [%].

Cost-effective application of vane controllers is at around 60 and 100 [%] of the rated airflow, at a constant speed.

7.6 Bypass control

This is when part of the air is diverted from the main airflow, in order to maintain the desired air quantity. The partial air quantity can either be expelled into the surroundings or reunited with the main airflow on the suction side (fig. 7.12).

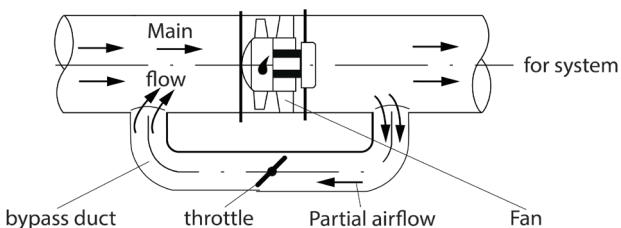

Fig. 7.12. Bypass system (figure)

The total pressure increase which a fan in bypass operation must overcome is lower than that in normal operation, there is necessarily a reduction in airflow in the duct network. The system characteristic becomes flat due to the opened bypass. This means that only fans with steep characteristics are suitable, such as radial fans with backward curved blades and axial fans (fig. 7.14-7.15).

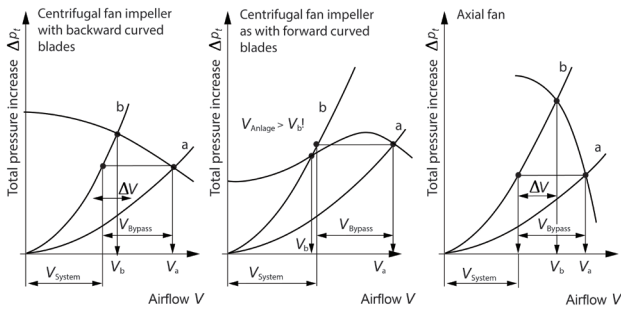

Fig. 7.13. Bypass control with different fans (figure)

Curve a = Bypass open

Curve b = Bypass closed

As seen in figure 7.13 (centre), for the relatively flat characteristic of the radial impeller with forward-curved blades, the total pressure increase will only change a little when the bypass is opened. This means it is almost impossible to achieve the desired airflow changes in the duct network. Therefore, the impeller with forward curved blades is only suitable for bypass control to a very limited extent.

Throttle control and bypass control change nothing on the fan itself, only the system. Since both methods are associated with relatively high losses, they should only be used for fans with small power ratings.

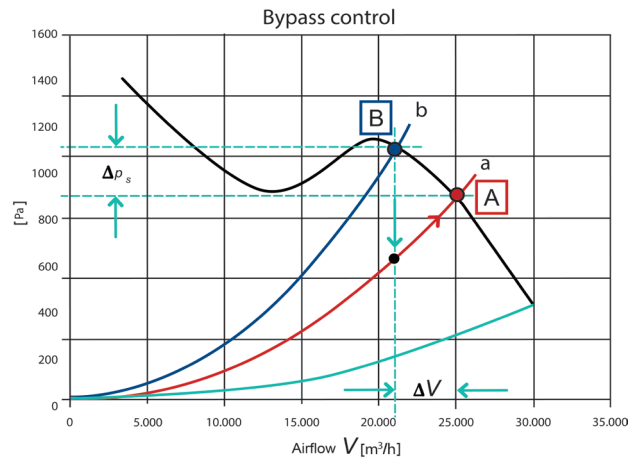

Fig. 7.14. Illustration of bypass control

System characteristic b = Bypass closed = Operating point B

System characteristic a = Bypass open = Operating point A

For systems with varying operating conditions, the throttle flaps can be adjusted using servo controllers so that automatic airflow regulation is possible.

8. Drive design

Basic type of construction	Derived types of construction	Basic type of construction	Derived types of construction
IM B3 IM 1001	IM V5 IM 1011 IM V6 IM 1031	IM B5 IM 3001	IM V1 IM 3011 IM V3 IM 3031
IM B35 IM 2001	IM V15 IM 2011 IM V36 IM 2031	IM B14 IM 3601	IM V18 IM 3611 IM V19 IM 3631
IM B34 IM 2101	IM 2111 IM 2131	IM B30 PAD	

Fig. 8.1. Different types of drive construction

8.1 Electrical and mechanical energy

Electrical power from the electricity network transforms to the useful work with lots of losses. For example losses in the frequency inverter, losses in the motor, losses in the impeller etc. (fig. 8.2)

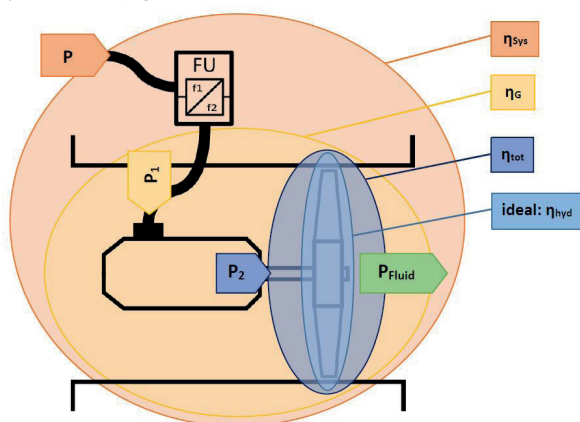

Fig. 8.2. P – electrical input power from the electric network, P₁ – electrical input power of the motor, P₂ – output power of the motor (available mechanical power at the motor shaft), P_{fluid} – energy input into the fluid

For IEC motors, the shaft output power P₂ (= specified mechanical power) is specified on the motor rating plate in watts [W] or kilowatts [kW] (fig. 8.3).

The electric power P₁ input to the motor can be calculated using the data given about the motor efficiency η_M on the rating plate, either using the formula

eq. 8.1-01 $\eta_M = P_2 / P_1$; $P_1 = P_2 / \eta_M$ P₁: Electrical input power
 P₂: Mechanical output power
 η_M: Motor efficiency

eq. 8.1-02 $P_1 = U \cdot I \cdot \cos \varphi \cdot \sqrt{3}$ [for 3-phase motors]

eq. 8.1-03 $P_1 = U \cdot I \cdot \cos \varphi$ [for 1-phase motors]

Example: Calculation of P₁ according to the data on the following motor rating plate

Motor & Co GmbH			
Typ 160			
a	3 ~ Mot.	Nr. 12345 - 88	d
b	400/690 V	29/27 A	e
c	S1	15 kW	cos φ 0,85
1430 1/min 50Hz			
Isa - KL F IP 54 t			
IEC34 1/VDE 0530			

Fig. 8.3. Motor rating plate

a Data on the rating plate [for 3-phase motors] (fig. 8.4)

b U = 400 [V] [31] P₁ = U · I · cos φ · √3

d I = 29,0 [A] P₁ = 400 · 29 · 0,85 · √3

e cos φ = 0,85 P₁ = 17,08 [kW]

c P₂ = 15 [kW]

[30] η_M = P₂ / P₁

η_M = 15 / 17,08

η_M = 0,878 · 100 = 87,8 [%]

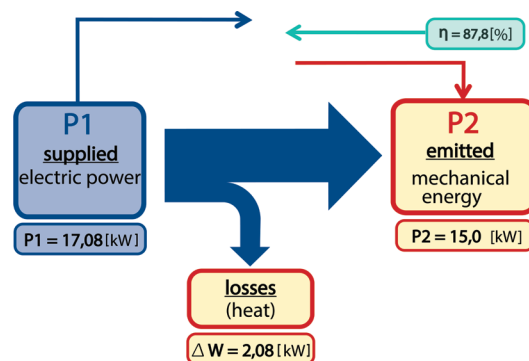

Fig. 8.4. P₁, P₂, η and heat loss

eq. 8.1-04 $W = P_1 - P_2$ [kW] ΔW : Loss (heat)

ΔW = P₁ - P₂ [kW]

ΔW = 17,08 - 15 [kW]

ΔW = 2,08 [kW]

- For external rotor motors, the electrical input energy P_1 is specified on the rating plate in watts [W] or kilowatts [kW].
- The technical parameters of the fan may deviate from the rated data of the drive motor.
- The impeller efficiency η_L is calculated using the output air power P_{air} and the output mechanical power P_2 of the drive motor (fig. 8.5).

eq. 8.1-05 $\eta_L = P_{air} / P_2 \cdot 100$ [%] η_L : Impeller efficiency

P_{air} : Output air power
 P_2 : Mechanical output power of the motor

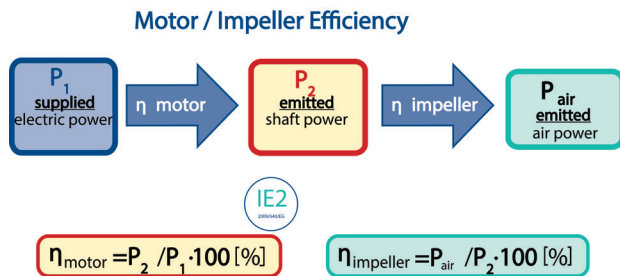

Fig. 8.5. Motor/impeller efficiency

The fan efficiency η_v is the product of the motor efficiency η_M and impeller efficiency η_L or can be calculated using the output air power P_{air} and the supplied electrical energy P_1 (fig. 8.6)

eq. 8.1-06 $\eta_v = P_{air} / P_1 \cdot 100$ [%] η_v : Fan efficiency

eq. 8.1-07 $\eta_v = \eta_M \cdot \eta_L$ [%] η_L : Impeller efficiency

η_M : Motor efficiency

P_{air} : Output air power

P_1 : Electrical input power

Fan efficiency (fig. 8.6)

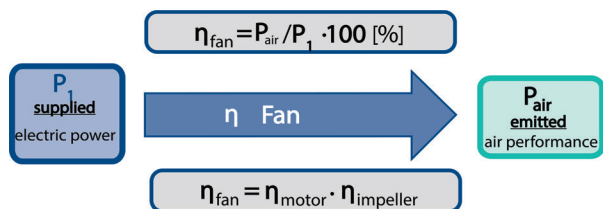

Fig. 8.6. Fan efficiency η_v

Example: $\eta_M = 0,878 = 87,8$ [%]

$\eta_L = 0,68 = 68$ [%]

eq. 8.1-07 $\eta_v = \eta_M \cdot \eta_L$

$\eta_v = 0,878 \cdot 0,68$

$\eta_v = 0,597 = 59,7$ [%]

The drive is determined by the application conditions and the corresponding requirements. Essentially, for fans complying with VDMA 24164, there is a range of very

different drive types. The most common form is probably the direct drive. The V-belt drive and the somewhat rarer coupling drive are described below in more detail.

Motors (direct drive)

The power requirement P_w to the shaft of the fan can be calculated.

eq. 6.2.1-01 $P_w = (V \cdot p_t) / \eta$ [W]
 V : Airflow [m³/h]
 p_t : Total pressure [Pa]
 η : Efficiency of fan [%]

A certain power reserve is added to the power requirement P_w . For directly driven fans this is approximately 5 – 10 [%], depending on the size around 10 – 20 [%] for V-belt driven fans, and, depending on the size of the impeller torque to be transmitted around 5 – 15 [%] for coupling driven fans.

An important criterion for selecting the motor is the value of its acceleration torque. This must be in a certain ratio to the mass moment of inertia of the fan so that a problem-free start-up is ensured. The mass moment of inertia J refers to the rotating parts of the fan, i.e. the impeller hub and shaft. It is the product of the mass of the rotating components multiplied by the square of the radius of gyration. This is determined experimentally and specified by the fan manufacturer.

The motor manufacturers generally permit a start-up time of 10 [s]. This can be used to check the motor according to the relationship (valid for the fan load):

eq. 8.1-08 $t_A = J \cdot \omega / M_{dyn}$ [s]

$\omega = \pi \cdot n / 30$

t_A : Start-up time [s]

J : Mass moment of inertia of impeller and motor [kg m²]

M_{dyn} : Dynamic torque [N m]

eq. 8.1-09 $M_{dyn} = 0,45 \cdot (M_s + M_{max}) - 0,33 \cdot M_l$ [s]

M_s : Motor starting torque [1/min]

M_{max} : Motor maximum torque [N m]

M_l : Load torque [N m]

This relationship is valid for direct drives. For V-belt drives, calculations should be made using the reduced mass moment of inertia J_{red} :

eq. 8.1-10 $J_{red} = J_M + (n_v/n_M)^2 \cdot J_v$

n_v : Fan speed [1/min]

n_M : Motor speed [1/min]

J_M : Motor mass moment of inertia [kg m²]

J_v : Impeller mass moment of inertia [kg m²]

The torque M_w can be calculated using the shaft power P_w and the fan speed n_v ; consult the motor manufacturer for the acceleration torque M_b .

8.2 Motors, direct drive

Motors

Sinusoidal AC voltage (fig. 8.7)

Alternating voltage or AC voltage is the name we give to an electrical voltage which changes polarity at regular intervals. On sinusoidal AC voltage, the peak value \hat{U} is 1.414 times (exactly $\sqrt{2}$) the RMS value U .

$$\hat{U} = U \cdot \sqrt{2} = U \cdot 1.414$$

The period length [T] is derived from the frequency [f].

$$T = \frac{1}{f}$$

A 50 Hz AC voltage results in a period length of

$$T_{50} = \frac{1}{50 \text{ [Hz]}} = \frac{1}{50} \text{ [s]} = 20 \text{ [ms]}$$

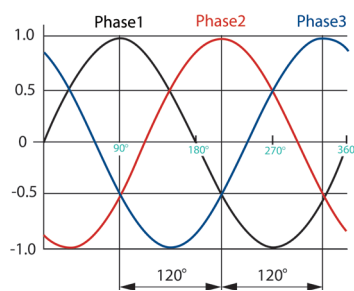

Fig. 8.7. 3-phase alternating current supply network

A three-phase alternating current supply network comprises three phases, the neutral conductor and earth (PE). The three phases are staggered in time by 120° . The voltage $U_{\text{Ph-N}}$ between phases and the neutral conductor is equal to the voltage $U_{\text{Ph-Ph}}$ divided by $\sqrt{3}$.

$$U_{\text{Ph-N}} = \frac{U_{\text{Ph-Ph}}}{\sqrt{3}}$$

External rotor motor

The external rotor motor was specially developed for fans. Whereas on a standard motor the rotor runs on the inside and the windings are arranged around the rotor in the stator, on an external rotor motor, the rotor is on the outside and rotates around the stator along with the windings.

The external rotor motor is positioned in the fan wheel. This reduces the fitting length, and the motor is also cooled by the airflow. These motors are available in single and three-phase versions, as well as EC motors.

IEC standard motors

In a three-phase induction motor, there is a rotating magnetic field generated by copper wire windings. The rotor contains aluminium bars which are short-circuited at each end using a short-circuit ring.

It is also called a squirrel-cage rotor or short-circuited rotor. The time-staggered voltage of the three phases rotates the magnetic field around the rotor. A voltage is induced in the bars, causing current to flow through the short-circuit ring, generating a magnetic field in the rotor. By swapping two phases, the rotating field and therefore the direction of rotation of the motor changes.

The magnetic field in the stator (copper wire winding) rotates quicker than the rotor. The greater the difference in speed, the bigger the electromagnetic field and the torque.

Were the rotor to reach the rotational speed of the magnetic field, no magnetic field could be generated in the rotor and the motor would not turn.

The difference between the rotational speed of the rotor and the speed of the rotating magnetic field is termed slippage. Under full load conditions, slippage varies by around 2 [%] and 7 [%].

The rotational speed n depends on the frequency and the number of pole pairs P , i.e. the number and arrangements of the windings. There are also pole-changing motors, i.e. motors with two or more speeds.

eq. 8.2-01

$$n \text{ [min}^{-1}\text{]} = \frac{f \cdot 60}{P}$$

Number of poles	2	4	6	8
Number of pole pairs P	1	2	3	4
Synchronous rotational speed [min ⁻¹]	3000	1500	1000	750
Rotational speed [min ⁻¹]	2790...2940	1395...1470	930...380	698...735

Efficiency classes to IEC 60034-30

The efficiency classes are specified as IE1, IE2, IE3, etc (fig. 8.8). The higher the IE class the lower the minimum efficiency level. The motors have fewer losses between input and output and therefore need less energy. This relates to single-rotation three-phase squirrel cage induction motors for 50 [Hz] or 50/60 [Hz] of 2-, 4-, and 6-pole design for a nominal voltage of up to 1000 [V] and output of 0,75...375 [kW].

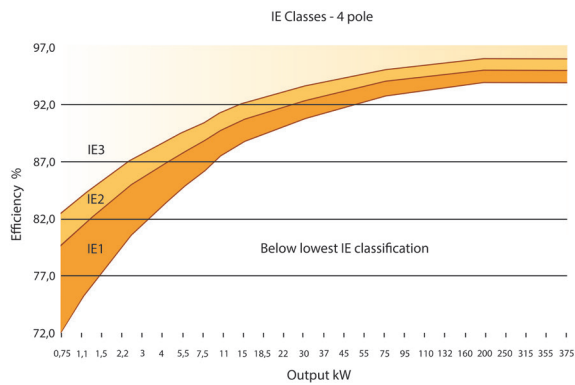

Fig. 8.8. Motor efficiency

EC motor (fig. 8.9)

An EC (electronically commutated) motor has commutation electronics and permanent magnets in the rotor. It is the permanent magnets which result in these motors being more efficient and needing less energy. Through electronic switches, the electronics integrated with the motor control the flow of a DC voltage to the relevant phase windings. The Hall Effect sensors signal the magnetic field of the rotor's permanent magnets to the electronics and the magnetic field is relayed further. The EC motor is not dependent on the frequency or number of pole pairs, but on the speed of the switching operations. Speed control is infinitely adjustable via a control signal, e.g. 0...10 [V]. The integrated electronics allow an easy connection and include motor protection which shuts down the motor in the event of a fault.

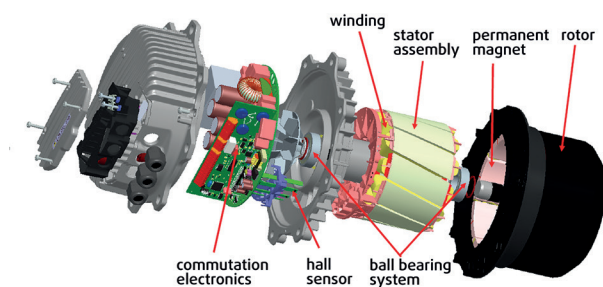

Fig. 8.9. EC motor

PM motor (fig. 8.10)

Permanent magnet (PM) motors also work with permanent magnets in the armatures, resulting in a reduction in energy losses compared to induction motors, as well as, in normal circumstances, a smaller increase in temperature in the motor and therefore longer service life. Since these energy losses on induction motors represent a significant proportion of the total losses for the motor, PM motors achieve significantly higher efficiencies, thereby exceeding the requirements of the new, globally standardised energy efficiency classes.

When current runs through the winding, a magnetic field is generated which attracts the permanent magnet of the rotor. As on an asynchronous motor, the magnetic field

rotates through the phase shift and the rotor follows. This results in a rotational movement which is dependent on frequency.

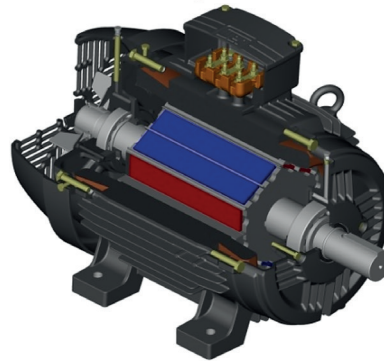

Fig. 8.10. Permanent magnet motor

As it was said above, on IEC motors, the shaft output P_2 is indicated on the rating plate in watts [W] or kilowatts [kW]. The rated electrical input can be calculated from the rating plate data via the efficiency η_M .

eq. 8.1-01

$$P_1 = \frac{P_2}{\eta_M}$$

or via the voltage U , the current I , the $\cos \varphi$ and on 3-phase motors $\sqrt{3}$:

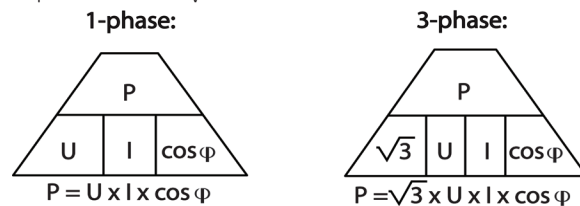

Fig. 8.11. 1-phase and 3-phase

On external rotor motors, the rated electrical input P_1 is indicated on the rating plate in watts [W] or kilowatts [kW].

When motors are used in fans, the technical parameters of the fan may deviate from the nominal data of the motor.

Motor protection

The motor temperature is monitored by a thermal relay (TW) / thermostatic switch (TK) or thermistor (PTC) in the motor. If the motor overheats, the motor must be disconnected from the mains via external switch units.

The thermal relay is a bimetallic normally closed (NC) switch. Some thermal relays automatically switch back once the motor has cooled down, others have to be reset by switching off the supply voltage.

A thermistor is a temperature-dependent resistor to DIN VDE V 0898-1-401 [2016-03] or VDE V 0898-1-401 [2016-03]. If the temperature in the motor rises past impermissible levels, the resistance increases. In addition, an evaluation unit (thermistor tripping device) is needed to switch off external switch units.

Motor Wiring

- With the motor's rated voltage of 230/400 [V], a star circuit must connect this motor to the three-phase supply network ($U_{LN} = 400$ [V]).
- Here the voltage of a motor winding is designed for a maximum voltage of 230 [V].
- The three-phase windings (W2-U2-V2) are grouped together in the terminal box at what is termed the star point. The voltage of the individual phases at the star point is 230 [V].

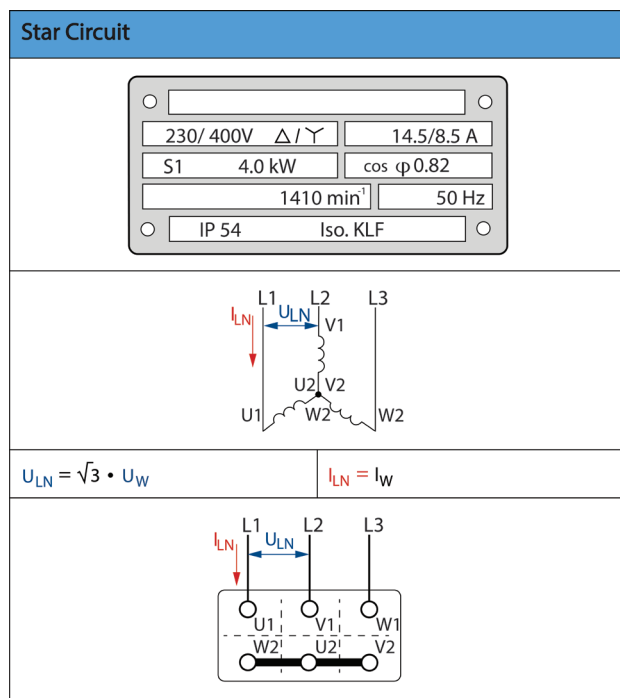

Fig. 8.12. The three phase winding

- With the motor's rated voltage of 400/690 [V], a delta circuit must be used to connect this motor to the three-phase supply network ($U_{LN} = 400$ [V]).
- Here each motor winding is designed for the maximum phase voltage of 400 V and can be connected directly.
- For direct starting, the ends of the winding are grouped together in the terminal box (U1-W2, V1-U2, W1-V2) and connected to the individual phases.

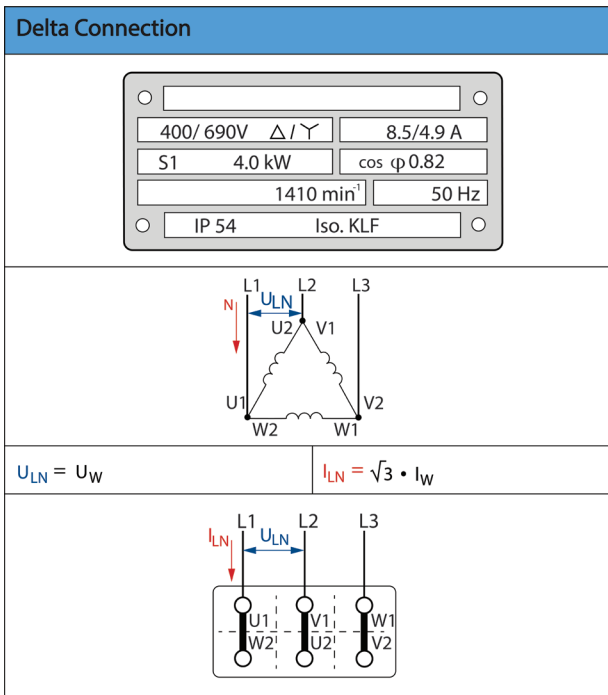

Fig. 8.13. The three phase winding

	Direct Motor Start	Star Delta Starter	Soft Starter	Frequency Inverter
Block Diagram				
Voltage Curve				
Network Load at Start-up	high	medium	low to medium	low
Current flow				
Relatively Start-up Current	4 ... 8x I _n (Motor-dependent)	1,3 ... 3x I _n (-1/3 compared to a direct start)	2 ... 6x I _n (reduced by voltage control)	≤ 1 (... 2x) I _n (adjustable)

Fig. 8.14. Motor startup variants

Drives

Drive design

The drive is determined by the application conditions and the corresponding requirements. Essentially, for fans under VDMA 24164, there is a range of very different drive types. The most common form is probably the direct drive. The V-belt drive and the somewhat rarer coupling drive are described below in more detail.

8.3 V-belt drive

The V-belt drive is common in ventilation and air conditioning. V-belts have excellent adhesion between the belt and the pulley. The V-belts should be designed in such a way that the belt speed is not greater than 20 [m/s].

Belts are selected using manufacturers' catalogues, taking into account the DIN 2218 standard. The transferable powers can be determined by the selection of the belt profile in conjunction with the pulley diameter and speeds.

In accordance with DIN 2218, 7753 and ISO 4184, the following belt profiles are available and are used for driving fans:

	Short name	Upper belt width b_o	Effective width b_e	Belt height h	Guide diameter of The Associated smallest discs according to DIN 2211 Teil 1 d_{min}
sheathed	SPZ	9,7	8,5	8	63
open-flank toothed	SPZ	9,7	8,5	9	50
sheathed	SPA	12,7	11	10	90
open-flank toothed	XPA	12,7	11	9	63
sheathed	SPB	16,3	14	13	140
open-flank toothed	SPB	16,3	14	13	100
sheathed	SPC	22	19	18	224
open-flank toothed	XPC	22	19	18	160

Note: open-flank belts can also be installed where sheathed belts have been used

- Advantages:
 - The speed can be adjusted to the desired operating point
 - It is possible to make subsequent corrections to the operating point
- Disadvantages:
 - The lower overall efficiency of the fan
 - Belt wear
 - Higher maintenance costs

8.4 Coupling

Detachable, elastic, direct-acting couplings are primarily used for ventilation (fig. 8.15).

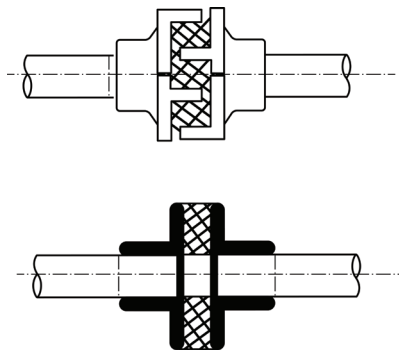

Fig. 8.15. Symbols for elastic couplings

This drive is most commonly used for large and heavy impeller designs with large inertias. Here the fan and motor bearings are independent.

With an elastic link (rubber, plastic, steel spring) between the coupling halves, elastic couplings connecting the motor and fan impeller provide the following particular advantages:

- Compensation of shaft expansion due to temperature changes
- Compensation for changes in shear forces
- Compensation of radial shaft movements, caused by bending torques
- Compensation of slight angular deviations in both shafts
- Compensation of vibration-exciting torques
- Compensation of critical speed regions, avoidance of resonances

The design of elastic couplings should comply with DIN 740, due to the laws of physics – and not, as is often still common according to purely empirical specifications.

In general, the basis for a coupling calculation is the fan speed n , and the rated moment at the fan shaft M_w or the shaft power P_w .

Because – depending on the type of coupling – coupling manufacturers have very different plus-factors / safety factors, in practice, it is not recommended to carry out the calculation by yourself.

If required, for an accurate calculation and determination of the appropriate coupling, the manufacturer must generally be consulted regarding the following specifications:

- The shaft power P_w to be transmitted in [kW].
- The operating speed of the fan being connected.
- This applies particularly to start-up couplings which work using a belt drive.
- Otherwise, operating speed = motor speed.
- V-belt drive pulley nominal diameter, a number of grooves and profile for belt-driven start-up couplings.
- Motor type and type of start-up.
- Type of operation; smooth or potential impact loading.
- Operating period and switching frequency.
- Maximum angular deviation of the shafts.
- Maximum ambient temperature.
- Any loading due to shear forces.
- Dimensions of the driven shaft, fit, groove.
- Type of bearing next to the shaft.
- Coupling on the driving or driven shaft.
- If required GD2 or the mass moment of inertia of the fan.

The following criteria should be incorporated in the calculation and design of couplings, which are also detailed in the DIN 740 standard:

- Loading due to torque impacts
- Loading due to a periodically oscillating torque
- Continuously oscillating torque
- Loading due to shaft displacement

In special cases, centrifugal clutches are also used; where the motor is first allowed to reach its rated speed and then the fan is sped up by the clutch using frictional forces until it reaches its operating speed.

A motor overload due to high torques is not possible. For this reason centrifugal clutches are also known as “Safety clutches”.

8.5 Speed control

Fan speed

Voltage controlled motors

Two-speed operation by switching between star and delta

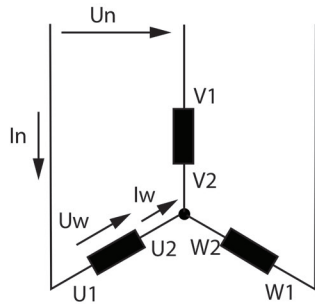

Fig. 8.16. Star circuit

In a star circuit (fig. 8.16), the voltage at the winding U_w is lower than the supply network voltage U_N :

$$U_w = U_N / \sqrt{3}$$

On a star circuit, the current I_w through the winding is equal to the current in the phase conductor I_N :

$$I_w = I_N$$

The fan runs at low speed.

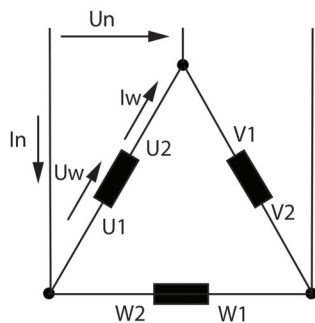

Fig. 8.17. Delta circuit

In a delta circuit (fig. 8.17), the voltage at the winding U_w is the nominal voltage U_N :

$$U_w = U_N$$

On a delta circuit, the current through the winding I_w is equal to the current in the phase conductor I_N :

$$I_w = I_N / \sqrt{3}$$

The fan runs at high speed.

Transformer-based speed change

Change in fan speed by reducing the voltage across a transformer (fig. 8.18). This can be performed incrementally or by infinite adjustment. The frequency is identical to the supply network frequency – it is the voltage that changes.

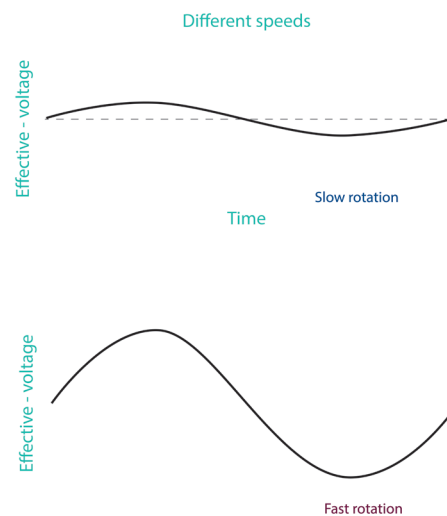

Fig. 8.18. Changing the fan speed reducing the voltage

Electronic speed change

Depending on the speed setting, an electronic switch (thyristor) switches the full sine wave from the supply network voltage (full speed) or blocks part of it, only allowing some of it through (fig. 8.19). This reduces the voltage at the motor and the result is a reduction in speed.

The phase is “chopped” = chopper voltage regulator

i Note: Phase chopping can cause additional noise in the motor

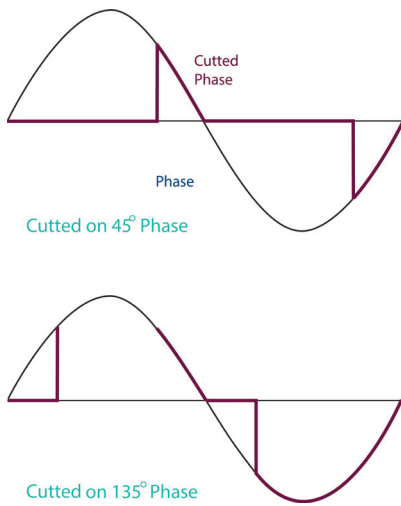

Blue = Sine wave of the supply network voltage
Pink = Voltage to the motor

Fig. 8.19. Changing the fan speed reducing the voltage

IEC Standard motors

Changing speed via frequency

A frequency converter changes the speed n by changing the frequency f . The speed n is derived from the frequency f of the motor and its number of pole pairs P :

$$n = (f \cdot 60) / P$$

The frequency converter changes the frequency via a clocked signal (PWM signal/clock frequency). The high frequency of the PWM signal means that the cable between the frequency converter and the motor has to be shielded (fig. 8.20). There is a restriction on the length of the cable between the frequency converter and motor.

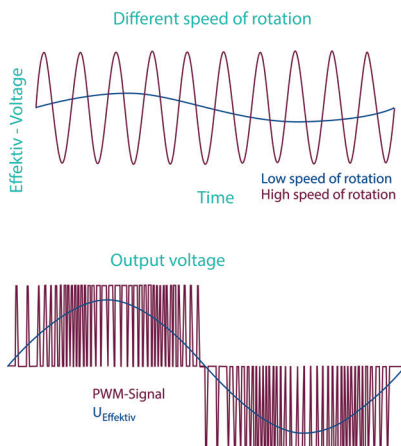

Fig. 8.20. Changing speed via frequency

External rotor motors

Changing speed via frequency

Frequency converter with omnipolar sine wave filter

(fig. 8.21-8.22)

The omnipolar sine wave filter filters the PWM signal so that a low-frequency sine wave voltage is output from the output of the frequency converter. This helps make the operation of the motor smoother and a shielded cable is not needed. Longer cable lengths can be used, and motors can be connected in parallel.

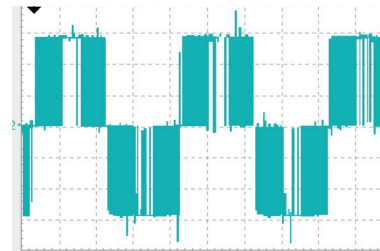

Fig. 8.21. Output voltage without omnipolar sine wave filter

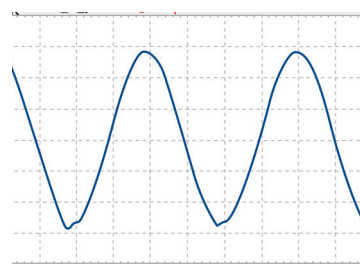

Fig. 8.22. Output voltage with omnipolar sine wave filter.

EC motor

An EC motor has an integrated power component (commutation electronics). The motor is connected to the supply voltage indicated on the rating plate and speed control is via a 0...10 [V] control signal or an external 10 [kiloohm] potentiometer. EC motors are efficient for their use of permanent magnets, saving on energy.

8.6 Control technology

Control

Control is the term used for an operation where an input variable influences an output variable based on certain defined correlations.

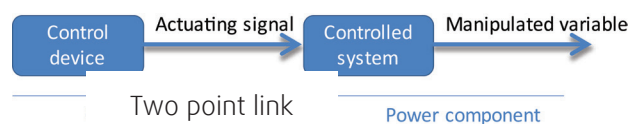

Closed-loop control

Closed-loop control is an operation in a system where the variable to be controlled is continually measured and compared to the setpoint. In the event of a deviation, the variable is corrected or adjusted.

The variable in question may be a temperature, humidity, air quality, pressure, air volume, etc. A sensor signals the actual values, and this value is compared in the closed-loop cc

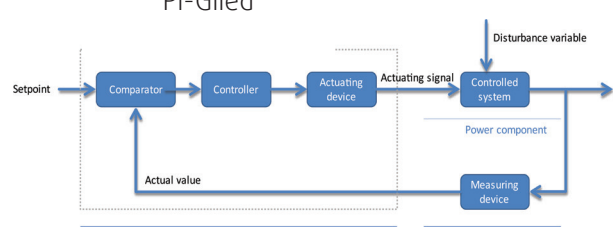

Two-step (closed-loop) control

At the specified setpoint, the output is switched on/off or switched over.

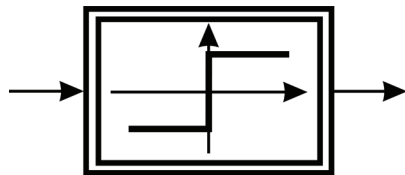

Two point link

Continuous (closed-loop) control

At the specified setpoint, the output is increased or reduced, as determined by the control parameters.

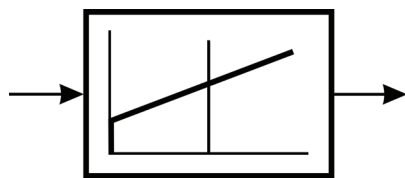

Pi-Glied

Closed-loop control technology

P-band (proportional controller)

The P-band is the deviation from the setpoint, at which the closed-loop controller has 100 [%] output.

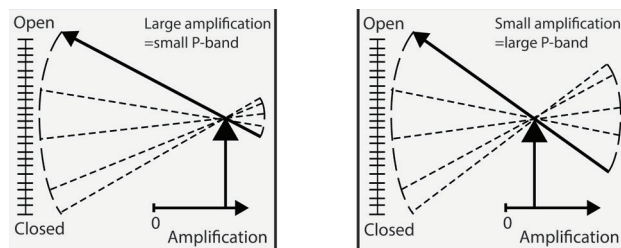

Integral time (integral controller)

A closed-loop controller which influences the output signal based on the size and time of the input signal.

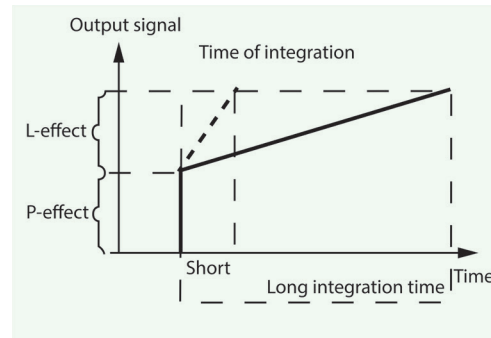

PI controller

Example: Filling a bucket with water

First, the tap is opened completely (P-effect), then the closing of the tap is performed continuously (L-effect) until the bucket is full.

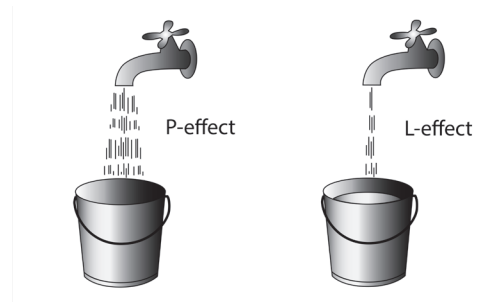

Cascade controller

Cascade (closed-loop) control is used for closed-loop control of room temperature. Here two closed-loop controllers are used. The first closed-loop controller is connected to the room temperature sensor, the second to the duct sensor in the supply air duct. The controllers are connected so that the output signal of the first controller is switched to the input of the second. The cascade factor is the amplification of the first controller, i.e. the amount by which the supply air temperature changes when there is a change in the room temperature of 1[°C].

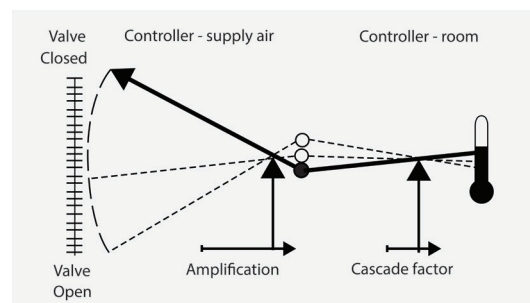

Supply air temperature control

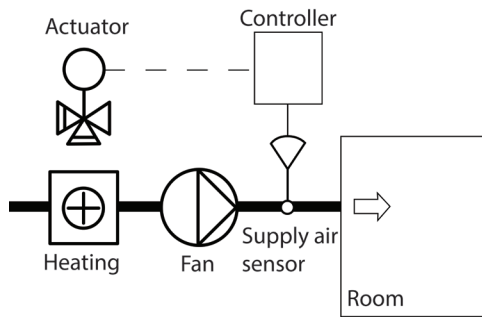

Room temperature control

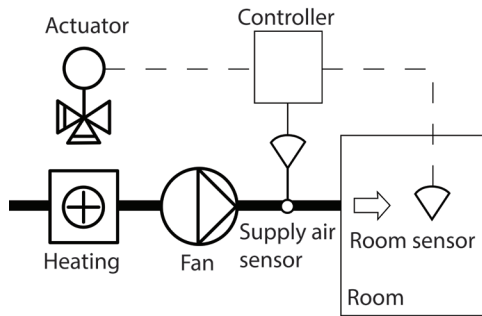

Outdoor temperature compensation

The outdoor temperature is captured via an additional temperature sensor. A change in setpoint is made on the basis of the measured temperature.

Example:

Above 10 [°C] the setpoint is e.g. 300 [Pa]. Below 10 [°C] the setpoint is reduced, and at -20 [°C] the setpoint is 200 [Pa].

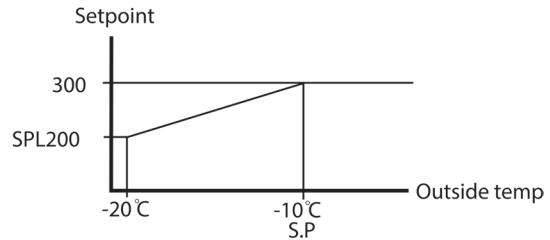

Sequence controller

“Sequence” means “following on”, and that is why another term for sequence controller is “follower controller”. This means that several actuators (output signals) can be controlled in sequence (one following the other). First, the first actuator takes control until it has finished doing its job, and then the second, and so on. A sequence controller is usually designed with two (e.g. cooling-heat) or three (e.g. cooling-recycling-heat) actuators. A neutral zone can be set between cooling and heating. This neutral zone (Nz) results in a higher set point for cooling.

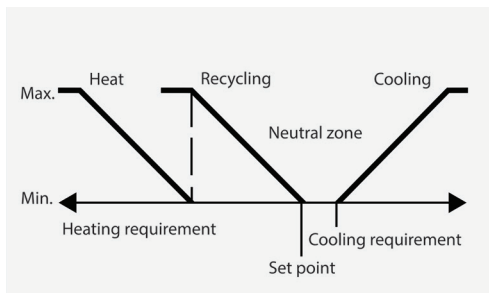

9. System controls monitoring

Monitoring systems for fans

Environmental awareness, energy efficiency and high-quality standards play an increasingly important role in ventilation and air conditioning. To get an ideal indoor climate – or process air – and economical performance data for air conditioning systems, continual monitoring of measured values and parameters are required. There is a

wide range of installable measurement equipment available for checking and regulating pressure, airflow, flow speed, vibrations, current consumption, voltage, temperature and relative humidity.

There follows a short description of examples of the most important measured values and parameters to be monitored.

9.1 Monitoring the system pressure

In many process applications, continuous and precise monitoring of under pressure, over-pressure or differential pressure is required. Here the manometer and pressure transducer is ideal for monitoring filters in ventilation and air conditioning, or for recording and safeguarding the differential pressure in closed spaces. Unnecessary energy input due to, for example, higher fan power or additional air heating can thus be avoided. This ensures good energy efficiency. But also the operating display of smoke extractors or hazardous gas extraction ducts – and the sign of container leaks – play a large role, preventing damage to health or damage to machines, plants and buildings.



Fig. 9.1. Differential manometer

The differential manometer (fig. 9.1) ensures permanent monitoring of under pressure, over-pressure or differential pressure. The measured value can always be read from the scale on the integrated U-tube. The electric switch contact can be set to any point on the scale using the knob.

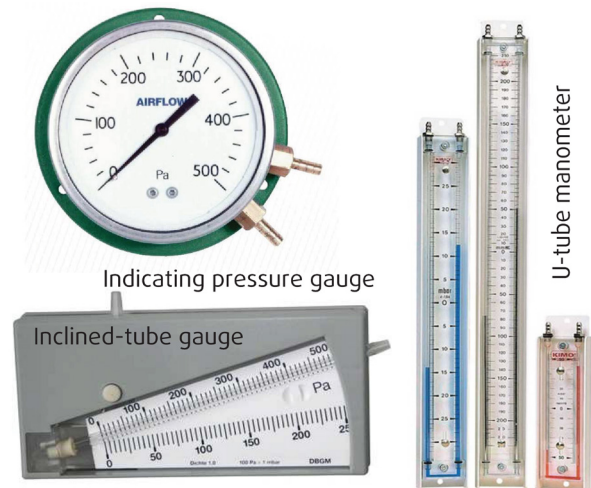

Fig. 9.2. Manometer (dial gauge, U-tube and inclined tube)

Dial gauge manometers are precise and reliable measurement instruments for displaying filter contamination in ventilation equipment (fig. 9.2). They are compact, durable and simple to use. The large and clear display is easy to read. Dial gauge manometers feature a high degree of measured value repeatability. They require no maintenance and have high long-term stability.

U-tube and inclined tube manometers are quick to apply, easy to level, and the measured value can be read quickly and accurately.

In addition, there are many portable manual measuring instruments for all kinds of applications.

9.2 Monitoring the airflow

In the construction industry, the measurement of airflow and airspeeds has become very important. Increasingly, ventilation systems provide effective and energy-efficient ventilation in private and public buildings. But also for many production processes, smooth and correct air distribution is important.

By using measurement equipment installed in the air duct, the parameters can be recorded and the ventilation system controlled in an ideal way. The result is proper ventilation for a pleasant climate and an uninterrupted work process.

The pitot tube is a recognised instrument for determining flow speed in ducts.

By using highly precise micro-manometers, a pitot tube measurement can provide much more accurate measured values than any non-elementary measurement method. At its tip, the pitot tube (fig. 9.3) records the overall pressure in the flow's direction, which comprises a dynamic and a static component.



Fig. 9.3. Prandtl's pitot tube

Airflow probes record the differential pressure to determine the flow speed/airflow in air ducts. Airflow probes comprise 2 pipes on a plate, which are assembled in a duct cross-section (fig. 9.4). On one pipe the holes face against the flow and collect the overall pressure; the shorter, curved pipe records the static pressure.

Due to the distribution of the holes, an average of the pressures is achieved. The ends of the pipes point outwards. The difference between these two pressures represents the pressure difference signal, which is related to the speed/airflow present.



Fig. 9.4. Measurement crosses (for round or rectangular ducts)

The Wilson flow grid (fig. 9.5) is a pressure sensor for measuring and controlling flow speed/throughput the volume in air ducts. It is based on fundamental principles and provides a reliable and continuous measured value. The flow grid comprises parallel or circularly arranged pipes for recording the dynamic pressure (overall pressure) and the reference pressure. These are merged into a single value in collection pipes.

The ducts are perforated in such a way that across the specified cross-section of the airflow, the average value of the differential pressure can be determined at both connections (inlet/outlet). This differential pressure is related to the flow speed so that by connecting suitable equipment, the average flow speed can be read off directly – or the signal can be used for control or data logging.

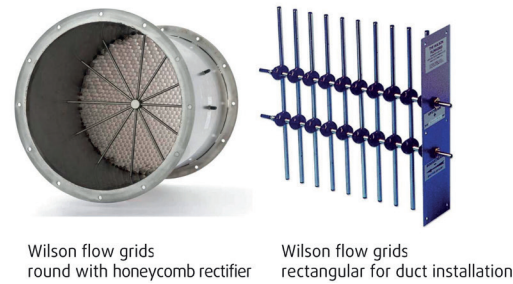

Fig. 9.5. Wilson flow grids (for round or rectangular ducts)

The air speed signal converters are suitable for temporary and permanent installation (fig. 9.6).

They can be used for air speed measurements in research and development laboratories, production facilities or in other areas. Measurement range, display and time constants can be selected and adapted to the particular application.

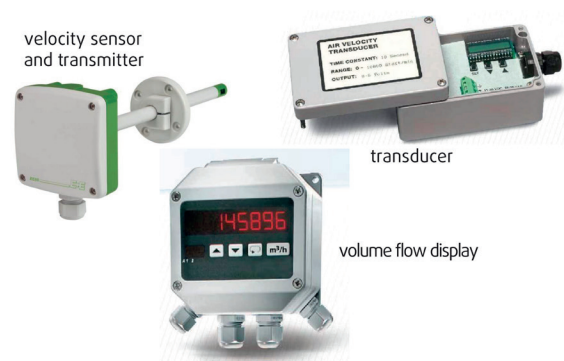

Fig. 9.6. Airflow measurements (sensor / transducer / display)

To measure the parameters pressure and volume in an existing system, measurement points must be selected where the flow conditions are as ideal as possible, to ensure the results are reproducible.

This is less problematic for pressure measurement, but for speed measurement (to determine the airflow) the selection of the correct measurement location is very hard to realise, due to the suboptimal (separated) flow.

As a matter of principle, the airflow should be measured in front of the fan, and the pressure measured closely in front of and behind the fan. This enables the total static pressure of the whole system to be recorded.

9.3 Monitoring the drive motor

Electrical and thermal monitoring of drive motors for fans are described in detail in the Theory book "Motors" and the Theory book "Speed controls".



Fig. 9.7. Tachometers



Fig. 9.8. Current clamp

In order to measure the speed of rotation and electrical parameters, usually tachometers (optic and laser) and current clamps are used correspondingly.

9.4 Vibration monitoring

Permanent vibration monitoring according to ISO 10816-3, 14694, 14695, 13350.

The causes of mechanical damage of fans are very different.

- Aerodynamic excitations
- Machine vibrations
- Frictional vibrations

lead to vibration-related problems.

Vibration monitoring enables changes of state, for example, on a fan, to be recognised early on and dealt with it. A permanent monitoring of the vibration state permits early recognition of deterioration or the start of the damage to the machine. This enables necessary maintenance and repair activities to be planned cost-effectively with minimal disruption. The vibration speeds (vibration state variables) are measured during the final acceptance procedure (fig. 9.9).



Fig. 9.9. Vibrometer

Operating states, limit values according to ISO 10816-3

Before the limit values are exceeded, appropriate measures for reducing them are required. Monitoring of the ventilation data: e.g. maintenance of the fan unit, cleaning the impeller/motor, rebalancing the impellers if necessary, re-lubricating the bearings, etc.

Machine monitoring is installed with the following aims:

- Protection from fatal damage to the machine environment and people
- Protection from unexpected machine downtime
- State-dependent maintenance planning
- Quality controls

Vibration sensor A (simple) (fig. 9.10)



Fig. 9.10. Sensor type A

Vibration monitoring – actual value recording

with adjustable sensors (limit value setting with switching point and response delay). Monitoring of the overall vibration state of the fan/machine according to DIN ISO 10816.

An alarm is triggered if the limit values are exceeded. It is possible for the parameters to be transmitted as a current signal (4 ... 20 [mA]) for connection to the process controller.

Vibration sensor B (with limit value settings) (fig. 9.11)



Fig. 9.11. Sensor type B

Stationary vibration monitoring – data storage / evaluation

Data logging using vibration sensors with real time signal storage for vibration speeds and roller bearing states. The evaluation and diagnostics are performed using appropriate diagnostics electronics. This enables bearing damage, imbalance and/or general vibrations to be analysed in order to detect corresponding trends. This permits state-oriented maintenance or inspection of the fan.

Vibration Control (installation) (fig. 9.12)

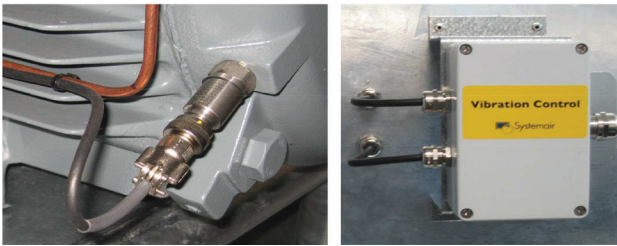

Fig. 9.12. Vibration control system

Online vibration monitoring – data storage / evaluation

Online monitoring using Internet technology

Reliable error detection by local diagnostics tools can be enhanced by using innovative tele-diagnostic systems. System operators can meet these new requirements by calling up external expertise with the click of a mouse. Stationary vibration monitoring with corresponding data analysis and evaluation is performed on the World Wide Web, making global access to diagnostics information via the Internet possible.

For exported plant, current machine states can be called up and analysed from remote locations; local activities can be planned and optimally prepared for. This means the risks remain calculable.

9.5 Monitoring of temperature and humidity of the medium

The quality of the ambient air is very important for our well-being: after all, the average European spends around 90% of their day inside buildings. Temperature, relative humidity and the proportion of CO or CO₂ in the air can have a negative impact on the indoor climate. This is detrimental to concentration, comfort and performance. In the long-term it can even result in damage to health. In particular, the increase in airtightness of buildings and the increased use of ventilation equipment make monitoring of the indoor air quality necessary. But the building itself – or sensitive products and machines – also react to, for example, undesired temperature fluctuations or too high a humidity. This can be easily determined when required,

using air quality measurement instruments. Reasons for a suboptimal indoor climate can be found and dealt with quickly.



Fig. 9.13. Devices for temperature and humidity measurements

9.6 Sound measurements

Sound power and pressure levels are the parameters which became very important in our days. In every place there are specific demands on the levels of sound according to sanitary norms etc.

That is why, every machine which can emit sound is tested after production to determine real levels of sound of this produced exemplar.

Microphones are used to measure sound pressure. The signal from microphone can then be input to some sort of analyzer. There are several methods of determining sound power, for example intensity, measuring contour, etc.



Fig. 9.15. Analyzer of spectrum



Fig. 9.14. Microfon

10. Special fans (safety-relevant devices)

10.1 Equipment fire safety

Equipment fire safety incorporates the totality of all technical equipment, plant and machine elements, with which the damaging fire is detected as early as possible so that help can be sought (e.g. fire alarms),

- The spread of a fire is prevented or limited (e.g. automatic fire extinguishing equipment and semi-stationary fire extinguishing equipment),
- People can be warned about the dangers resulting from the fire and the firefighting and emergency services can be informed (fire alarms and alarm equipment)
- Ensuring an almost smoke-free layer to evacuate buildings and achieve improved fire fighting conditions for the fire services (smoke and heat extraction system and over-pressure systems).

Prerequisites for a fire

- Flammable material
- Oxygen
- Correct mixing ratio
- Ignition source

Smoke emission

In a fire, the smoke is the largest problem for the people in the building and for the firefighters. The consequences are dramatic:

In less than 3 minutes, due to the smoke generated, visibility decreases so much that the affected people lose their orientation and can no longer get to safety. The rapid spread of toxic smoke is always underestimated. A further difficulty is the rapidly increasing concentration of the gas carbon monoxide (CO).

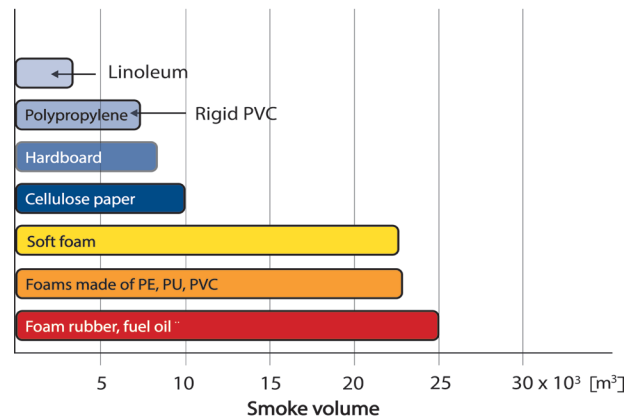

Fig. 10.1. Smoke quantities

Components of smoke

The combustible materials, the basis for every fire, produce smoke in considerable quantities and concentration. So all kinds of substances are generated during combustion, including hydrogen cyanide, ammonia, carbon monoxide and carbon dioxide; which are respiratory poisons with life-threatening effects.

The development of a fire over time

The hot pyrolysis gases collect under the ceiling and are further heated by the fire. If the gas mixture is hot enough, it will ignite suddenly. This is called FLASHOVER.

Ignition phase - smouldering	Flashover	Fully-developed fire	Fire dying out Cooling phase

Table 10.1. Development of a fire over time

Conclusion

- Smoke and heat extraction systems are essential to rescue people and property.
- Only the installation of a smoke and heat extraction system can prevent hazards from smoke and combustion gases.
- Not without reason is the requirement for a smoke and heat extraction system a component of every building code in the Federal Republic of Germany.
- It must not be forgotten that every electric smoke and heat extraction system automatically offers the additional benefits of daily ventilation.

Hydrogen cyanide (HCN)	Ammonia (NH ₃)	Carbon monoxide (CO)	Carbon dioxide (CO ₂)
Occurs in the combustion of polyurethane, foam mattresses, upholstered furniture, wool, silk, down	Occurs during the low-temperature carbonisation of plastic fibres, wool, silk, nylon	Occurs during the low-temperature carbonisation of nearly all organic materials	Generated in open fires
Respiratory poisons affecting the blood and nerves	Respiratory poisons causing irritation and corrosivity	Respiratory poisons causing suffocation	Respiratory poisons causing suffocation

Table 10.2. Toxicity and effect of smoke

Smoke removal: powered smoke and heat extraction systems

The basis for the function of powered smoke and heat extraction systems

- Preventative fire safety according to DIN 18232-2 and VdS CEA 4020
- Smoke-free emergency escape routes
- Smoke-free entry for firefighters for quick rescue operations and extinguishing attempts
- Delay or prevention of FLASHOVER
- Reduction of damage due to smoke and pyrolysis
- Supply of fresh air in case of fire

European standard

DIN EN 12101-3 (Smoke and heat control systems)

Part 3: Specification for powered smoke and heat control ventilators

Who creates the European standard?

CEN, the European Committee for Standards, in Brussels.

Since this is a European standard, the CEN members are required to apply this as an international directive, and to carry over the European standard unchanged into the national standard.

Who are the CEN member states?

Member states (as of January 2006)					
AT	Austria	FR	France	MT	Malta
BE	Belgian	GB	Great Britain	NL	Netherlands
CH	Switzerland	GR	Greece	NO	Norway
CY	Cyprus	HU	Hungary	PL	Poland
CZ	Czech Republic	IE	Ireland	PT	Portugal
DE	Germany	IS	Iceland	RO	Romania
DK	Denmark	IT	Italy	SE	Sweden
EE	Estonia	LU	Luxembourg	SI	Slovenia
ES	Spain	LV	Latvia	SK	Slovakia
FI	Finland	LT	Lithuania		

Table 10.3. CEN member states

Which institutes are allowed to test in Europe?

- Certified testing institutes, general
- The European Community authorises the certifying testing institutes
- The authorised and certified testing institutes and their facilities for testing are documented by NANDO.
- <http://ec.europa.eu/enterprise/newapproach/nando/>

Examples of authorised and certified testing institutes

- BSRIA, UK, Bracknell, NB 0480
- TUM, DE, Munich, NB 1511
- CTICM, F, Saint Aubin, NB 1166
- LGAI, E, Barcelona, NB 0370

Testing temperature and function period corresponding to the classification acc. DIN EN 12101 - 3		
Class	Temperature [°C]	Minimum function period [min]
F200	200	120
F250	250	120
F300	300	60
F400	400	120
F600	600	60
F842	842	30
unclassified	specified by the client	specified by the client

Table 10.4. Temperature-time classification

Temperature-time classification

In the DIN EN 12101-3 standard, the classification according to testing temperature and functional period is defined as follows.

Certification procedure

For example, a certification procedure according to the following diagram.

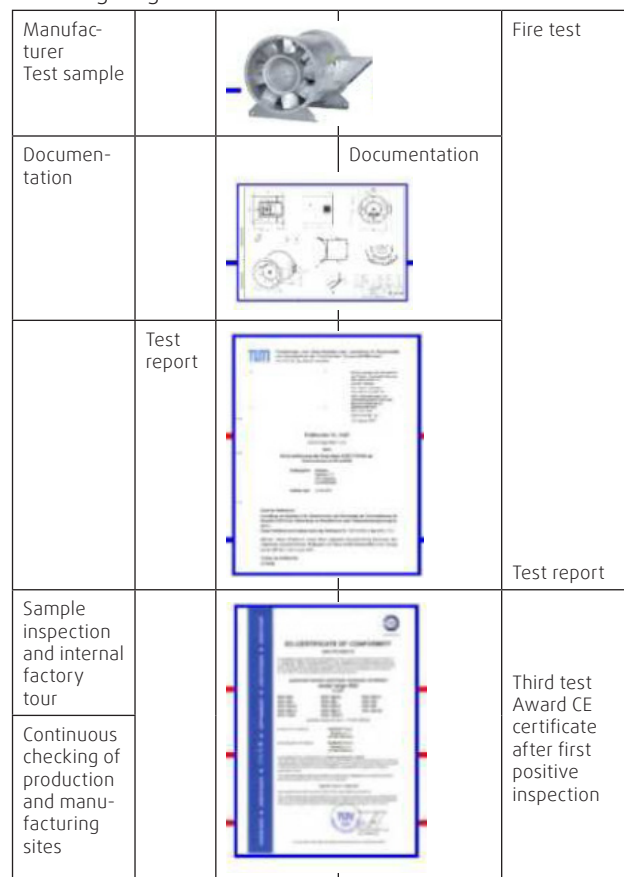

Table 10.4. Certification procedure

10.2 Explosion protection

This relationship can be illustrated by the so-called “explosion triangle”:

Ignition source	Explosion	Flammable substance in a finely distributed form
-----------------	-----------	--

Table 10.5. Explosion triangle

Explosion protection measures

Explosion protection includes all the measures taken to prevent hazards due to explosions.

The principle of integrated explosion protection according to the ATEX Product Directive 94/9/EC (ATEX 95) requires that the explosion protection measures are taken in a specific sequence, as shown below.

- Avoid explosive atmospheres

Measures which prevent or limit the formation of hazardous potentially explosive atmospheres. These measures should take priority over all others.

One approach is also, if possible, to replace flammable materials with non-flammable materials. A measure is also inertization, e.g. within the equipment, to prevent a potentially explosive atmosphere by removal of oxygen.

- Avoid effective ignition sources

Measures which prevent the ignition of hazardous potentially explosive atmospheres. Here, an important prerequisite is the correct classification of zones in order to select equipment with an adequate level of safety.

- Explosion protection by design

Measures which limit the effects of an explosion to a harmless level. This could be, for example, explosion suppression systems in containers, which detect an explosion starting and extinguish it before it reaches dangerous proportions. Other examples here are flame arresters in ducts or other explosion relief equipment.

Equipment Groups

It would not be economical, and sometimes it would also be impossible, to design all explosion-protected electrical equipment to meet the maximum requirements, independent of the application concerned. Therefore, the equipment is categorised into groups, depending on the properties of the potentially explosive atmospheres for which they are destined.

Equipment Group	Equipment
I	Electrical apparatus for potentially explosive atmospheres for mining
II	Electrical apparatus for all other potentially explosive atmospheres

Table 10.8. Equipment Groups

Equipment Categories

Equipment categories describe protection and the area of application of equipment (in accordance with the ATEX Directive 94/9/EC). Equipment which is a potential ignition source and may cause an explosion must undergo an ignition risk analysis. Resulting from this, measures must be put in a place corresponding to the essential safety requirements, in order to exclude a risk of ignition due to this piece of equipment.

Categories of Equipment Group I: Underground and overground mining plant at risk due to firedamp/dust

Equipment Group	Category	Explosion hazard	Degree of safety to be ensured
I	M1	Areas at risk long-term and permanently due to firedamp (dust is also taken into account).	A very high degree of safety. Safe even when two independent faults occur. Two redundant protective measures. Continued operation must be ensured
I	M2	Areas which may be at risk due to firedamp (dust is also taken into account).	A high degree of safety. It must be possible to switch off the equipment if a potentially explosive atmosphere occurs

Table 10.6. Equipment Group I – Equipment Categories M1 + M2

Categories of Equipment Group II: Other Ex areas

Equipment Group	Category	Explosion hazard	Degree of safety to be ensured
II	1 G	Combustible gases, vapours or mist	A very high degree of safety. Safe even when two independent faults occur.
II	1 D	Combustible dusts	
II	2 G	Combustible gases, vapours or mist	A high degree of safety. Safe even when a fault occurs.
II	2 D	Combustible dusts	
II	3 G	Combustible gases, vapours or mist	A normal degree of safety. Safe in normal operation.
II	3 D	Combustible dusts	

Table 10.7. Equipment Group II – Category

Equipment in Equipment Group I is subdivided into two categories, equipment in Equipment Group II is subdivided into three categories; each with different levels of safety. The required protective measures depend on the respectively necessary level of safety.

The Equipment Group I is subdivided into the categories M1 and M2.

See table 10.8

The Equipment Group II is subdivided into the categories 1, 2 and 3.

See table 10.9

Classification of zones in accordance with ATEX

Areas subject to potentially explosive atmospheres are subdivided into zones, depending on the frequency and duration of the occurrence of hazardous potentially explosive atmospheres.

The operator of a plant must assess whether there is a risk of explosion in an area and classify the zone accordingly.

- Zone 0

A place in which an explosive atmosphere consisting of a mixture with an air of flammable substances in the form of gas, vapour or mist is present continuously or for long periods or frequently.

- Zone 1

A place in which an explosive atmosphere consisting of a mixture with an air of flammable.

Substances in the form of gas, vapour or mist are likely to occur during normal operation occasionally.

- Zone 2

A place in which an explosive atmosphere consisting of a mixture with an air of flammable substances in the form of gas, vapour or mist is not likely to occur during normal operation but, if it occurs, will persist for a short period only.

- Zone 20

A place in which an explosive atmosphere in the form of a cloud of combustible dust in air is present continuously, or for long periods or frequently.

- Zone 21

A place in which an explosive atmosphere in the form of a cloud of combustible dust in the air is likely to occur during normal operation occasionally.

- Zone 22

A place in which an explosive atmosphere in the form of a cloud of combustible dust in the air is not likely to occur during normal operation but, if it occurs, will persist for a short period only.

See table 10.10

General rules for the terms “continuously, or for long periods or frequently”, “occasionally” and “for a short period” are:

- Continuously, or for long periods or frequently: for the greater part of the time, relating to the effective operating time (> 50 [%]).
- For a short period: a few times a year for approx. 30 minutes.
- Occasionally: everything which does not come under the heading of “long periods” or “frequently”.

Types of ignition protection

The ignition of a potentially explosive mixture by equipment can be prevented by various types of ignition prevention. In areas where the occurrence of potentially explosive atmospheres is to be reckoned with, only explosion-protected equipment may be used. This may be designed with different ignition protection. If required, combinations of different ignition protection can also be used. The ignition protection is standardised.

All the general requirements for the equipment are summarised in the standards

- IEC 60079-0 (in Europe EN 60079-0) for gases and vapours
- IEC 61241-0 (in Europe EN 61241-0) for dusts
- EN 13463-1 for non-electrical equipment

The standards for types of ignition protection can extend or revoke requirements.

See Table 10.11

Combustible materials as a mixture with air	Length of time the hazardous potentially explosive atmosphere is present		
	Continuously, over long periods or frequently (> 1,000 [hrs/year])*	Occasionally (10 - 1,000 [hrs/year])*	Never or briefly (< 10 [hrs/year])*
Gases, vapours, mist	Zone 0	Zone 1	Zone 2
Dusts	Zone 20	Zone 21	Zone 22

* The specified periods are not standardised guide values and serve only to provide a basic reference.

Table 10.9. Classification of zones in accordance with ATEX

Type of ignition protection	Name	Description/comments	Standard NEW (IEC/EN)	Standard OLD
General provisions	-	-	IEC 60079-0, EN 60079-0	EN 50014
Protection by flameproof enclosure "d"	Ex d	Parts which may ignite in a potentially explosive atmosphere are enclosed in a housing. This can withstand the pressure of an internal explosion of a potentially explosive mixture, preventing the explosion from spreading to the atmosphere surrounding the housing.		
Purged / pressurised encapsulation	Ex p	The formation of a potentially explosive atmosphere inside an enclosure is prevented by using an ignition protection gas. This maintains an internal over-pressure compared with the surrounding atmosphere. If necessary, the inside of the enclosure is permanently supplied with this ignition protection gas, so that flammable gas mixtures are diluted. px = Application in Zone 1, 2 py = Application in Zone 1, 2 pz = Application in Zone 2	IEC 60079-2, EN 60079-2	EN 50016
Powder filling	Ex q	The housing of the electrical equipment is filled with a fine-grain filler. During correct operation, this prevents the potentially explosive atmosphere around it from being ignited by an arc originating in the housing. Neither ignition due to flames, nor ignition due to high temperatures of the housing surface may occur.	IEC 60079-5, EN 60079-5	EN 50017
Oil immersion	Ex o	Electrical equipment or parts of electrical equipment are submerged in a protective fluid (e.g. oil) so that a potentially explosive atmosphere above the surface or outside the enclosure cannot be ignited.	IEC 60079-6, EN 60079-6	EN 50015
Increased safety	Ex e	Here additional measures are taken to increase the degree of safety when preventing the possibility of impermissibly high temperatures and the generation of sparks and arcs in internal or external parts of electrical equipment, which rarely occur during normal operation of the said equipment.	IEC 60079-7, EN 60079-7	EN 50019

Table 10.10. Types of ignition protection for electrical apparatus in potentially explosive atmospheres

Temperature class	Highest permissible surface temperature of the equipment	Ignition temperature of the flammable materials
T1	450 [°C]	> 450 [°C]
T2	300 [°C]	> 300 [°C] to < 450 [°C]
T3	200 [°C]	> 200 [°C] to < 300 [°C]
T4	135 [°C]	> 135 [°C] to < 200 [°C]
T5	100 [°C]	> 100 [°C] to < 135 [°C]
T6	85 [°C]	> 85 [°C] to < 100 [°C]

Table 10.11. Ignition temperatures and temperature classes

Explosive atmosphere	Directive 1999/92/EC (ATEX 137)	Explosive atmosphere present	Directive 94/9/EC (ATEX 95)
	Classification of zones		Equipment requirement (category)
Gas	Zone 0	Continuously, over long periods or frequently	1G
	Zone 1	Occasionally	2G or 1G
	Zone 2	Never, seldom or briefly	3G or 2G or 1G
Dust	Zone 20	Continuously, over long periods or frequently	1D
	Zone 21	Occasionally	2D or 1D
	Zone 22 Conductive dust Non-conductive dust	Never, seldom or briefly	2D or 1D 3D or 2D or 1D

G = Gases, vapours, mist
D = Dust

Table 10.11. Selection criteria in accordance with ATEX 95 and 137

Ignition temperatures and temperature classes

In a potentially explosive atmosphere, ignition due to heat can result from equipment with high surface temperatures.

The ignition temperature of combustible gas, vapour or combustible dust is the lowest temperature of a heated surface at which the ignition of the gas/air or the vapour/air mixture occurs. In effect, it shows the lowest temperature value at which a hot surface can ignite the corresponding potentially explosive atmosphere

See table 10.12

Selection criteria for equipment and protective systems

In all areas where potentially explosive atmospheres may be present, equipment and protective systems must be selected using the categories according to the Directive 94/9/EC (ATEX 95). The connection between the category according to Directive 94/9/EC regarding the zone according to Directive 1999/92/EC (ATEX 137) is shown in Annex II of the Directive 1999/92/EC.

See Table 10.13

In particular, in these zones, the following categories of equipment must be used, as far as they are suitable for gases, vapours, mists and/or dust (see Table 14):

- in Zone 0 or Zone 20: Equipment of Category 1
- in Zone 1 or Zone 21: Equipment of Category 1 or Category 2

- in Zone 2 or Zone 22: Equipment of Category 1, Category 2 or Category 3

See table 10.13

Marking in accordance with ATEX

In addition to the normal information (manufacturer, type, serial number, electric data), the data regarding explosion protection must be incorporated in the marking. On every piece of equipment, according to the ATEX Directive 94/9/EG, the marking must be applied clearly and ineradicably, according to the minimum specifications described by Annex II No. 1.05, as well as the stipulated markings for the type of ignition protection in the related standard.

The CE marking on the equipment confirms the adherence to all the applicable EU directives for the equipment.



		Seehöfer Strasse 45 97944 Boxberg GERMANY	
Fan type: DVEX 400D4		PA-Nr:	
0,39kW	230 / 400V	3 ~ 50Hz	1,31 / 0,76A 1350 r/m
'A=81s	'A/ 'N = 3,4	Insulationclass F	
Speedcontrollable 15 to 100% by reducing the voltage			
For thermal overload protection use type U-EK230E (PTB03ATEX3045)			
 0820		 II 2G c	
		Ex e IIB T3 SP07ATEX3131X	

Fig. 10.2. Marking in accordance with ATEX

Temperature classes						
Explosion group	T1 (450 [°C])	T2 (300 [°C])	T3 (200 [°C])	T4 (135 [°C])	T5 (100 [°C])	T6 (85 [°C])
IIA	Acetone (540 [°C])	1,2 Dichloroethane (440 [°C])	Benzene (220 - 300 [°C])	Acetaldehyde (140 °C)		
	Ammonia (630 [°C])	Cyclohexanone (430 [°C])	Diesel fuel (220 - 300 [°C])			
	Benzene (555 [°C])	1-amyl acetate (380 [°C])	Aircraft fuel (220 - 300 [°C])			
	Ethane (515 [°C])	n-butane (365 [°C])	Heating oil (220 - 300 [°C])			
	Ethylacetate (460 [°C])	n-butyl alcohol (340 [°C])	n-hexane (240 [°C])			
	Acetic acid (485 [°C])					
	Carbon monoxide (605 [°C])					
	Methanol (455 [°C])					
	Propane (470 [°C])					
	Toluol (535 [°C])					
IIB	Town gas (560 [°C])	Ethanol (425 [°C]) Ethylene (425 [°C]) Ethylene oxide (440 [°C])	Ethylene glycol (335 [°C]) Hydrogen sulphide (270 [°C])	Ethyl ether (180 [°C])		
IIC	Hydrogen (560 [°C])	Acetylene (305 [°C])				Carbon disulphide (95 [°C])

Table 10.12. Ignition temperatures and temperature classes of flammable gases and fumes

10.3 Explosion protection – protection against aggressive gases

What are aggressive media?

Inorganic gaseous pollutants

- Sulphur oxides SOX
- Nitrogen oxides NOX
- Ammonia NH₃
- Hydrogen sulphide H₂S
- Halogens HCl, HF, HBr, HJ
- Flue gases
- Acids
- Alkalis
- Organic gaseous pollutants, hydrocarbons
- Mineral and plant oils
- Organic acids
- Organic alkalis
- Solvents / VOC, volatile organic substances
- Smells, unpleasant-smelling organic substances
- Dioxins / furans
- PAN / PCB, polycyclic aromatic hydrocarbons, carcinogenic
- Halons, halogenated hydrocarbons

Abbreviation	general chemical resistance to resistant to	permitted temperatures	no resistance to not resistant to
High grade steels			
	see resistance list of the manufacturers		
* 1.4101	as well as 1.4105		
* 1.4305	as well as 1.4301, 1.4303	(-) 20 [°C] to +400 [°C] and higher	see empirical values from the manufacturer
* 1.4401	as well as 1.4404, 1.4408, 1.4409		
* 1.4571	as well as 1.4581		
Plastics			
PVC PVDF	acids, alkalis, alcohol, aliphatic hydrocarbons, saline solutions, mineral and plant oils	0 [°C] to +60 [°C] (-) 20 [°C] to +100 [°C]	aromatic and chlorinated hydrocarbons, esters and ketones
	Apparatus, tank, and ductline construction.	0 [°C] to 60 [°C]	
PA	mineral and plant oils, greases, waxes, fuels, weak alkalis, aliphatic and aromatic hydrocarbons	0 [°C] to +100 [°C]	concentrated, oxidising acids, chlorine gas, sodium hypochlorite (bleach), ozone, hydrogen peroxide, phenols
PP-PP-FR (PPs)	aqueous solutions of acids, alkalis and salts, large number of weak organic solvents positive experiences in fan and system engineering	0 [°C] to +100 [°C]	not UV resistant concentrated, oxidising acids, halogens
PE PE-FR (PE's)	aqueous solutions of acids, alkalis and salts, large number of weak organic solvents	0 [°C] to +100 [°C]	concentrated, oxidising acids, halogens
	positive experiences in air conditioning and ductline construction	(-) 20 [°C] to +60 [°C]	
GRP- CFRP	weak acids, weak alkalis, alcohol, benzene, benzene, oils and solvents	0 [°C] to +110 [°C]	strong acids, strong alkalis, ammonia, acetone, esters and ketones
PPS	dilute mineral acids, alkalis, aliphatic and aromatic hydrocarbons, oils and greases, hot water vapour, hydrolysis resistant.	0 [°C] to +200 [°C]	not UV resistant concentrated, oxidising acids, halogens
	positive experiences in fan and system construction		
PEEK	to the majority of chemicals	0 [°C] to +250 [°C]	concentrated sulphuric acid, nitric acid and some halogenated hydrocarbons

Table 10.13. Extract: Protection against aggressive media

Protection against aggressive media

All data given in the resistance tables is based on industrial experience and data provided by the material manufacturers.

The reference temperature for each given chemical resistance is always room temperature. In case of higher temperatures, a heat-related reduction in resistance must be taken into account for plastics and elastomers.

See table 10.15

Explanation of the short descriptions of the materials

The abbreviations for plastics relate mainly to the respective base polymer. Capital letters used are standardised in DIN EN ISO 1043-1 and DIN ISO 1629 (Rubbers). The abbreviations facilitate the writing of the chemical names of plastics according to the IUPAC regulations. For the identification of particular properties within a class of plastics, further letters can be added after the hyphen.

Abbreviations of plastics

- PVC, polyvinyl chloride
- PVDF, polyvinylidene fluoride
- PA, polyamide
- PE, polyethylene
- PE- FR, polyethylene, low flammability according to DIN 4102 B1
- PP, polypropylene
- PP- FR, polypropylene, with low flammability according to DIN 4102 B1
- PPS, polyphenylene sulphide
- GRP, glass fibre reinforced plastic
- CFRP, carbon fibre reinforced plastic
- PEEK, polyetheretherketone
- ... - el, electrically conductive thermoplastics with a surface resistance < 109 [Ohm] according to ISO 80079 - 36 + ISO 80079 - 37 [Nov. 2019]

Areas of application with special requirements for conveying aggressive gases

Area of application

Protection against harmful substances: Harmful substances which occur during work or manufacturing processes are dealt with directly using specially designed extraction systems (ventilators) and special filter units, to comply with approval requirements and immissions specifications.

These requirements must be met by the following technologies and systems.

- Waste treatment and composting plants
- Emission control systems
- Agricultural technology
- Biogas plants
- Chemical and pharmaceutical industry
- Dust extraction equipment for aggressive particles and dust
- Galvanising plants
- Laboratory equipment
- Medical technology
- Clean room technology
- Drying technology
- Process technology

Regulations

TA – Luft (German Technical Instructions on Air Quality Control)

These technical instructions protect the general public and the neighbourhood against the harmful effects of air pollutants on the environment and to take precautions against the harmful effects of air pollutants on the environment to achieve a high protection level for the environment as a whole

TA Luft is intended for use by the approving authorities for industrial and commercial systems requiring approval and is binding for them. Based on the general requirements of TA Luft, the relevant authorities draw up requirements, which have to be fulfilled by the plant operator. Existing, old plants must also achieve the state-of-the-art within a certain transitional period, and reduce pollutant emissions.

Immissions requirements

TA Luft stipulates that harmful substances (immissions) transported by the air, as a result of the licensing of the plant, should not exceed limits which could cause harm, for instance immissions values for:

- Dust precipitation: 0.35 [g/m³] annually

- Sulphur dioxide: 20 [$\mu\text{g}/\text{m}^3$] (annually and from October 1 until March 31)
- Nitrous oxides (given as nitrogen dioxide): 30 [$\mu\text{g}/\text{m}^3$] (annually)
- Hydrogen fluoride and gaseous, inorganic fluorides (given as fluorine): 0,4 [$\mu\text{g}/\text{m}^3$] (annually)

Emissions requirements

TA Luft includes general emissions requirements for particular air pollutants, for example:

- Total dust, including particulate matter
- Dust-like inorganic substances
- Gaseous inorganic substances
- Organic substances
- Substances that are carcinogenic, mutagenic, or toxic to reproduction, as well as persistent, highly accumulative and highly toxic organic substances
- Strong-smelling substances
- Substances harmful to the soil In addition to the general emissions requirements, specific requirements for particular types of plants are stated:
- Heat generation, mining, power industry
- Stone and earth industry, glass, ceramics building materials
- Steel, iron and other metals including processing
- Chemical products, medicinal products, mineral oil refining and processing
- Surface treatment with organic substances (e.g. printing, painting/coating)
- Production of plastic sheets and other processing of resins and plastics
- Wood pulp
- Foodstuffs, luxury foodstuffs, animal feed, as well as agricultural products
- Re-utilisation and disposal of waste and other substances
- Storage, loading and unloading of substances and preparations

Stricter emissions requirements and appropriately advanced technology are documented above all in the reference documents (BAT reference documents, BAT conclusions). These are published by the European Commission. The European Member States must ensure that the emissions values given are achieved by the plants concerned at the latest four years after the publication of the BAT conclusions. This only applies to some plants regulated by TA Luft: larger and particularly environmentally relevant plants, the approval and control of which are regulated in the EU-Member States by the Industry emissions guidelines.

Further laws, guidelines and standards:

Federal Pollution Control Act (BImSchG, revised version 17/05/2013)

Industrial Emissions Directive 2010/75/EU dated 24/11/2010

DIN 277 - T1, 2 Floor areas and volumes of buildings

DIN 1946 - T7 Air-conditioning plants in Laboratories

DIN 4102 Fire behaviour of building materials

DIN EN ISO 12100

2011 Safety of machines-General principles for design risk assessment and risk reduction

DIN EN 12792 Ventilation of buildings

DIN 12924 Laboratory equipment fume hoods

DIN EN 14470 Laboratory equipment cupboards

DIN EN 16789 Practical application – ventilation of non-residential buildings

EN 14175 Requirements for laboratory fume hoods

DIN EN 15252 Practical application – Ventilation of non-residential buildings

DIN EN 15423 Ventilation of buildings – fire protection in ventilation systems

VDMA 24 167 Fans – safety requirements

VDMA 24 169 Constructional explosion protection measures for fans

DIN EN 1507 - T2 Leak tightness classes of air duct systems

Guideline 94/9/EG Equipment for use in potentially explosive atmospheres

11. Formulas

Equation No.	Naming	Equation	Page
3.1.1-01	Gas equation	$\rho = p_1 / (R \cdot T)$ $[p_1 = p_a - p_s]$	13
3.1.2-01	Air density as a function of temperature	$\rho_1/\rho_2 = T_2/T_1$ $\rho_1 = \rho_2 \cdot (T_2/T_1)$ Index 1: 20[°C] Index 2: XX[°C]	13
3.1.2-02	Effect of temperature on the pressure increase	$\Delta p_{t1} / \Delta p_{t2} = \rho_1/\rho_2 = T_2 / T_1$	13
3.1.2-03	Effect of temperature on the driving power	$P_{w1} / P_{w2} = \rho_1/\rho_2 = T_2 / T_1$	13
3.1.2-04	Altitude formula	$P_H = p_a \cdot e^{(-H_a/7990)}$	13
3.2.1-01	Pressure variant of the Bernoulli equation with geodetic pressure component	$\rho/2 \cdot c^2 + P_s + \rho \cdot g \cdot H_a = \text{constant}$	14
3.2.1-02	Pressure variant of the Bernoulli equation	$\rho/2 \cdot c^2 + P_s = P_d + P_s = P_{\text{total}}$	14
3.3.1-01	Continuity equation	$m = \rho \cdot c \cdot A = \text{constant}$	14
3.3.1-02	Continuity equation	$m = \rho \cdot c_1 \cdot A_1 = \rho \cdot c_2 \cdot A_2 ;$ $c_2 = c_1 \cdot (A_1/A_2)$	14
3.4.2-01	Dynamic pressure	$p_{d1} = \rho/2 \cdot c^2$	14
3.4.3-01	Total pressure	$P_t = P_s + P_d$	14
3.5-01	Pressure loss of round ducts	$\Delta p_v = \lambda \cdot (l / d) \cdot p_d$	15
3.5-02	Pressure loss of ducts of any cross section	$\Delta p_v = \lambda \cdot (l / d_h) \cdot p_d$	15
3.5-03	Hydraulic diameter of any cross-sectional	$d_h = 4 \cdot (A / U)$	15
3.5-04	Pressure loss of rectangular ducts	$\Delta p_v = \lambda \cdot (l \cdot (a+b) / 2 \cdot a \cdot b) \cdot p_d$	15
3.5-05	Hydraulic diameter of rectangular ducts	$d_h = 2 \cdot a \cdot b / (a + b)$	15

Equation No.	Naming	Equation	Page
3.5-06	Pressure drop of annular ducts	$\Delta p_v = \lambda \cdot (l / (d_2 - d_1)) \cdot p_d$	15
3.5-07	Pressure loss in molded parts	$\Delta p_v = \zeta \cdot \rho / 2 \cdot c^2 = \zeta \cdot p_d$	16
3.5-08	Pressure loss caused by sudden cross-sectional expansion (shock loss)	$\Delta p_v = \zeta \cdot \rho / 2 \cdot (c_1 - c_2)^2$	16
3.5-09	Static pressure recovery	$\Delta p_{st} = (p_{d1} - p_{d2}) \cdot \eta_{diff}$	16
3.6-01	System curve	$\Delta p_t = f(V^2)$	16
4.2-01	Sound pressure	$L = 20 \cdot \lg(p/p_0)$	19
4.2-02	Length of the sound wave	$\lambda = c/f$	19
4.2-03	Sound power	$W = \int \frac{\bar{p}^2}{\rho c} ds$	19
4.2-04	Sound power	$L_w = 10 \cdot \lg(W/W_0)$	19
4.6-01	Sound power	$L_w = L_x + 50 \cdot \lg(u_2) + 20 \cdot \lg(D_2)$	21
4.6-02	Sound power	$L_w = L_{1x} + 10 \cdot \lg(V) + 20 \cdot \lg(P_v)$	21
4.9-01	Calculation of sound pressure level	$L_{pA} = L_{wA} + 10 \cdot \lg \left[\frac{Q}{4\pi r^2} + \frac{4}{A_{eqv}} \right]$	24
4.9-02	Calculation of reverberation time	$T = 0,163 \cdot \frac{V}{A_{eqv}}$	24
4.9-03	Calculation of equivalent absorption area A_{eqv}	$A_{eqv} = \alpha_1 \cdot S_1 + \alpha_2 \cdot S_2 + \dots + \alpha_n \cdot S_n$	25
6.2.1-01	Installation pressure loss	$\Delta p_{syst} = \zeta_{syst} \cdot p_d$	39
6.2.1-02	Power on the shaft	$P_w = (V \cdot p_t) / \eta$	42

Equation No.	Naming	Equation	Page
6.2.1-03	Conversion losses in the diffuser	$U_v = p_{d1} - p_{d2} - p_s$	42
6.2.1-04	Total pressure of the fan-diffuser system	$p_t = p_s + p_{d2} + U_v$	42
6.2.1-05	Power saving	$P_{WE} = 100 \cdot (P_{WoD} - P_{WmD}) / P_{WoD}$	42
6.3-01	Similarity laws for volume	$V_1/V_2 = (n_1/n_2) \cdot (d_1/d_2)^3$	43
6.3-02	Similarity law for pressure	$\Delta p_1/\Delta p_2 = (n_1/n_2)^2 \cdot (d_1/d_2)^2$	43
6.3-03	Similarity law for power	$P_{w1}/P_{w2} = (n_1/n_2)^3 \cdot (d_1/d_2)^5$	43
6.3-04	Proportionality laws for volume	$V_1/V_2 = (n_1/n_2)$	43
6.3-05	Proportionality law for pressure	$\Delta p_1/\Delta p_2 = (n_1/n_2)^2 = (V_1/V_2)^2$	43
6.3-06	Proportionality law for power	$P_{w1}/P_{w2} = (n_1/n_2)^3 = (V_1/V_2)^3$	43
6.3-07	Affinity laws for volume	$V_1/V_2 = (d_1/d_2)^3$	43
6.3-08	Affinity law for pressure	$\Delta p_1/\Delta p_2 = (d_1/d_2)^2$	43
6.3-09	Affinity law for power	$P_{w1}/P_{w2} = (d_1/d_2)^5$	43
6.4-01	Fan efficiency	$\eta = (\Delta p_t \cdot V) / P_w$	44
6.4-02	Dimensionless characteristic numbers, pressure range	$\Psi = \Delta p_t / (\rho/2 \cdot u_2^2)$	44
6.4-03	Dimensionless characteristic numbers, flow range	$\Phi = V / (u_2 \cdot (\pi \cdot d_2^2/4))$	44
6.4-04	Dimensionless characteristic numbers, performance range	$\lambda = \Phi \cdot \Psi / \eta$	44

Equation No.	Naming	Equation	Page
6.4-05	Dimensionless characteristic numbers, diameter range	$\delta = \psi^{3/4} / \varphi^{1/2}$	44
6.4-06	Dimensionless characteristic numbers, speed range	$\sigma = \varphi^{1/2} / \psi^{3/4}$	44
6.4-07	Dimensionless characteristic numbers, throttle range	$\tau = \varphi^2 / \psi$	44
6.6.0-00	Mounting A, B	$\Delta p_t = \Delta p_{s1} + p_{d2}$	45
6.6.0-00	Mounting C	$\Delta p_t = \Delta p_s + p_{d2} - p_{d1}$	45
6.6.0-00	Mounting D	$\Delta p_t = \Delta p_s$	45
6.9-01	Total pressure	$\Delta p_t = p_{t2} - p_{t1} = p_{s2} + p_{d2} - (p_{s1} + p_{d1})$	51
8.1-01	The electric power P1 input to the motor	$\eta_M = P_2 / P_1$	61
8.1-02	The electric power P1 input to the motor	$P_1 = U \cdot I \cdot \cos \varphi \cdot \sqrt{3}$ [for 3-phase motors]	61
8.1-03	The electric power P1 input to the motor	$P_1 = U \cdot I \cdot \cos \varphi$ [for 1-phase motors]	61
8.1-04	Losses	$W = P_1 - P_2$	61
8.1-05	Impeller efficiency	$\eta_L = P_{air} / P_2 \cdot 100$ [%]	62
8.1-06	Fan efficiency	$\eta_V = P_{air} / P_1 \cdot 100$ [%]	62
8.1-07	Fan efficiency	$\eta_V = \eta_M \cdot \eta_L$ [%]	62
8.1-08	Start-up time	$t_A = J \cdot \omega / M_{dyn}$	62
8.1-09	Dynamic torque	$M_{dyn} = 0,45 \cdot (M_s + M_{max}) - 0,33 \cdot M_l$	62

Equation No.	Naming	Equation	Page
8.1-10	Reduced mass moment of inertia	$J_{red} = J_M + (n_V/n_M)^2 \cdot J_V$	62
8.2-01	Rotational speed	$n = \frac{f \cdot 60}{P}$	63

12. Sources

Prof. Dipl. Ing. Willi Bohl , Vogelbuchverlag, Würzburg

Prof. Dr. E.Y. Yudin, Russland

Herr Thomas Lechner; Dr. Edwin Becker, Prüftechnik GmbH, Ismaning

Dipl. Ing. Walter Wagner, Vogelbuchverlag, Würzburg

Josef Lexis , Gentner Verlag, Stuttgart

Dr. A.G. Korovkin, Russland

Prof. Dr.-Ing. Wolfgang Elmendorf, Vogelbuchverlag, Würzburg

Published by: Systemair GmbH, 97944 Boxberg, Germany

Editors: Elke Rehmet, Martin Zumsteeg and Sergey Karadzhi

Authors: Martin Zumsteeg, Dipl.Ing., TH Stuttgart and TU Berlin; Sergey Karadzhi, Magister MIPT and Ph.D. BMSTU

13. Index

- A**
- Abbreviations of plastics..... 85
 - AC voltage..... 66
 - Affinity law 44
 - Air density..... 13
 - Airflow coefficient 45
 - Airflow direction 28
 - Airflow measurement in the system . 55
 - Altitude dependency 13
 - ATEX..... 80
 - Axial fan 27
- B**
- Basic principles of sound 19
 - Belt drive..... 30
 - Bernoulli equation 14
 - Blade control..... 60
 - Bypass control..... 58
- C**
- Calculation of sound pressure level... 25
 - Casing 30
 - Characteristic diagrams..... 38
 - Classification of zones..... 81
 - Continuity equation 14
 - Control technology..... 71
 - Controlling fans 58
 - Counterrotating fans..... 29
 - Coupling..... 69
 - Crossflow fan..... 36
 - Current clamp 76
- D**
- Damper..... 52
 - DC voltage..... 67
 - Definition of pressures 14
 - Delta circuit..... 70
 - Density 56
 - Dependencies of air density..... 13
 - Diagonal fan..... 35
 - Differential manometer..... 74
 - Diffuser..... 16, 27, 42, 43
 - Dimensionless parameters 45
 - Direction factor..... 24
 - Directions of rotation..... 32
 - Drive 64
 - Dynamic pressure 14, 18
- E**
- EC motor..... 67
 - Efficiency..... 38, 45
 - Efficiency classes 66
 - Elastic coupling..... 30
 - Emissions requirements..... 86
 - Energy..... 64
 - Equipment categories..... 80
 - Equipment fire safety..... 78
 - Expansion joint..... 52
 - Explosion group..... 83
 - Explosion protection..... 80, 84
 - External rotor motor 29, 66
- F**
- Fan efficiency 65
 - Fan in the system 51
 - Filter..... 20
 - Fireproof fan..... 29
 - Fire safety 78
 - Free wheel..... 31
 - Frequency 19
- G**
- Gas equation..... 13
 - Guide vanes 27, 28, 36
- H**
- Hub..... 28, 35
 - Hub ratio..... 28
 - Humidity..... 77
- I**
- IEC standard..... 66, 71
 - Ignition protection 81
 - Immissions requirements..... 85
 - Influence of medium density 56
 - Inlet and outlet disturbances..... 39
 - Inlet nozzle..... 27, 30
 - Intencimetry 77
- J**
- Jet fan 29
- L**
- Laws of similarity..... 44
- M**
- Meridional acceleration..... 35
 - Mixed-flow 35
 - Mixed-flow fan..... 26
 - Monitoring 74
 - Motor protection 67
 - Motors 66
 - Motor wiring 68
- P**
- Parallel installation..... 48
 - Pitot tube 74
 - PM motor 67
 - Power 64
 - Power coefficient..... 45
 - Pressure coefficient..... 45
 - Pressure loss..... 15
 - Pressure measurement 53
 - Pressure measurements in situ..... 18
 - Proportionality law 44
- R**
- Radial fan 30
 - Resistance coefficient 16
 - Reversible fan..... 29
 - Rotating stall..... 37
- S**
- Scroll casing 31
 - Selection criteria 46
 - Series installation..... 50
 - Silencers 22
 - Similarity laws 21
 - Smoke emission 78
 - Speed control..... 58, 70
 - Sound power 19
 - Sound measurements 77
 - Sound pressure..... 19, 24
 - Sources of sound..... 20
 - Stalls 60
 - Star circuit 70
 - Static pressure..... 14, 18, 35
 - Surge effects 37
 - System curve..... 16
- T**
- Tachometers..... 76
 - Temperature 77
 - Throttle control..... 58
 - Total pressure 14, 13
 - Types of drive 29
 - Types of installation 47
- V**
- V-belt..... 68
 - Velocity distribution in the duct..... 17
 - Vibrations 34, 51
 - Vibration sensor..... 76
 - Vibrometer..... 76
 - Vane control..... 58

